

■ Features

- SMD construction, and low profile.
- High Impedance and Excellent Frequency Characteristic.
- Self Electromagnetic Shielding.
- Low Magnetic Flux Leakage.

■ Applications

- LED Light, TV game, Monitor, etc.
- EMI common-mode noise.

■ Product Identification

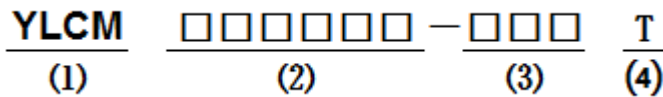

- (1) : Type
- (2) : Dimensions
- (3) : Impedance
- (4) : Taping

■ Shapes and Dimensions (Unit: mm)

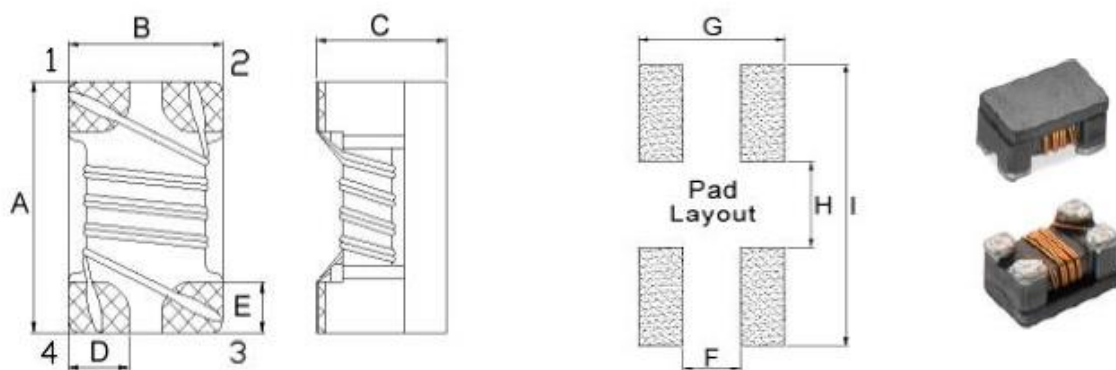

TYPE	A	B	C	D Typ.	E Typ.	F Typ.	G Typ.	H Typ.	I Typ.
YLCM4532EL	4.5±0.2	3.2±0.2	2.8±0.2	1.2	1.0	0.7	3.8	2.5	4.8

■ Circuit Diagram

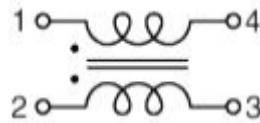

■ Note

- 1, No printing on the product.
- 2, Damage area diameter less than 0.4mm is allowed.

■ YLCM4532EL Series

Part Number	Common mode Impedance (Ω @10MHz)	Inductance (μ H) @100KHz/0.1V	DC Resistance (Ω)Max.	Rated Current (mA)Max.	Rated Volt.(Vdc) Max.	IR(Ω)Min.
YLCM4532EL-110T	300Min	11	0.60	250	50	10M
	600Typ	(+50%/-30%)				
YLCM4532EL-220T	500Min	22	1.00	200	50	10M
	1200Typ	(+50%/-30%)				
YLCM4532EL-510T	1000Min	51	1.00	200	50	10M
	2800Typ	(+50%/-30%)				
YLCM4532EL-101T	2000Min	100	2.00	150	50	10M
	5800Typ	(+50%/-30%)				

1. Rated Current: Temp.rise 40°C Typ
2. Operating Temperature: -40°C up to +125°C
- 3.Storage Temperature: -20°C up to +40°C, 75% RH max.

■ Material List

NO.	ITEM	DESCRIPTION
1	CORE	FERRITE
2	WIRE	P180 G1
3	ADHESIVE	5890LC
4	TIN	107H

Reliability Testing

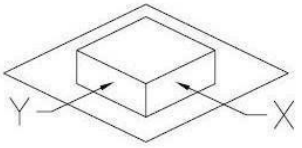
Operating Temperature	- 40 to + 125 °C (Contain Heating coil)
Appearance Inspection	No external defects by visual inspection
Terminal Strength 	After soldering , between copper plaet and terminals of coils , push in two directions of X , Y with standing 10N(1.02kg) for10+/-2 sec. Terminal should not peel off. (Refer to figure at right)
Heat endurance of reflow soldering	Refer to figure
Insulating resistance	Over 100 MΩ at 100V D.C . between wire and core .
Dielectric Strength	Apply at 0.5KV 3mA for 1 minute between wire and core .
Temperature characteristics	Inductance coefficient (0~2,000) × 10 / °C (- 40 ~ + 125 °C)
Humidity characteristics	Inductance deviation within ± 10% , after 96 hours in 90~95% relative humidity at 40 ± 2 °C and 1 hours drying under normal condition .

A test is made under the above mentioned condition , and it is kept for 2 hours in the normal

Recommended soldering temp.Graph

IR Reflow profile

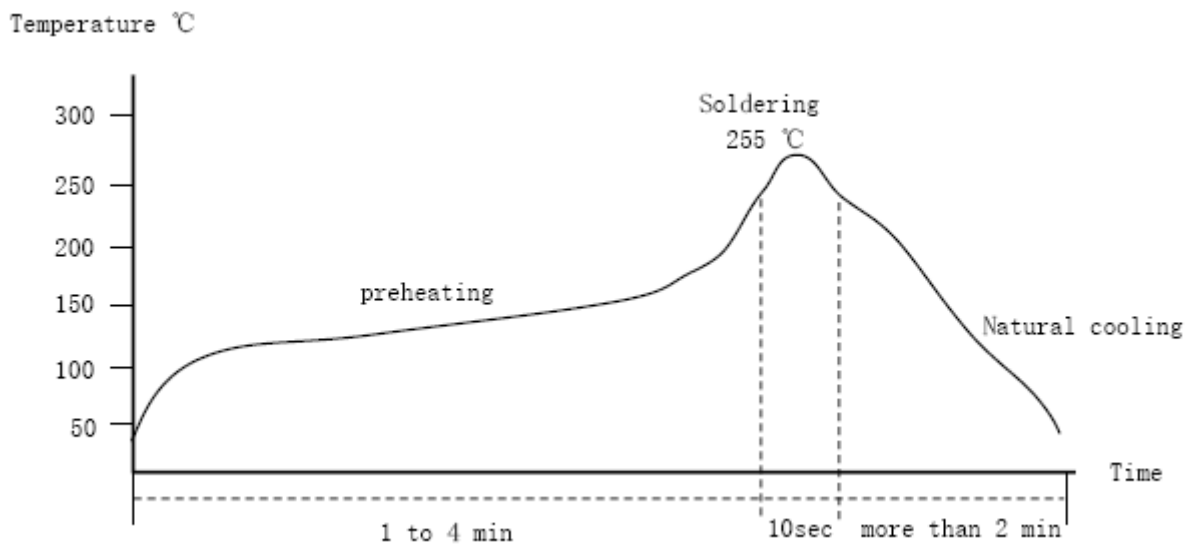

Temperature and humidity. After that,no mechanical and electrical defect should be found.

Taping Dimensions(Unit:mm)

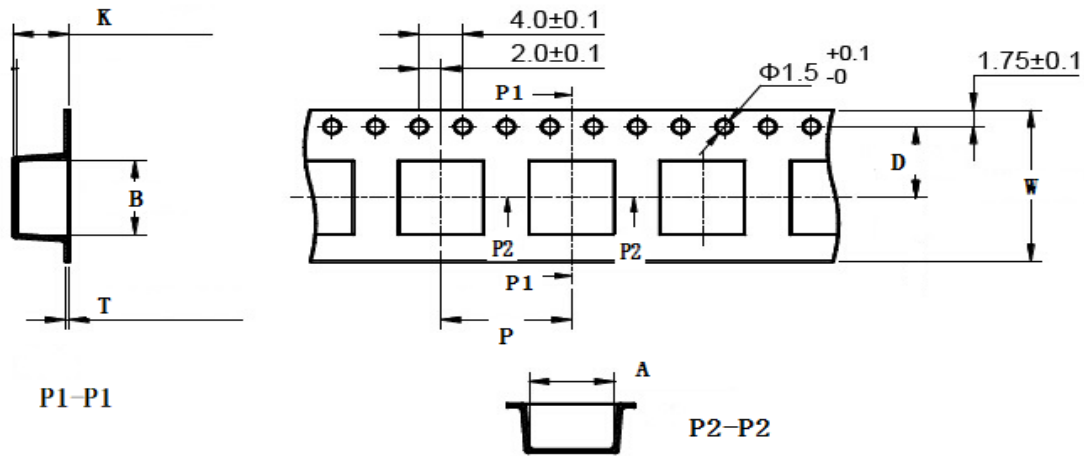

TYPE	W	A	B	D	P	K Max	T Max	MPQ
YLCM4532EL	8.00	3.30	3.30	3.50	4.00	1.90	0.25	2000

Reel Dimensions(Unit:mm)

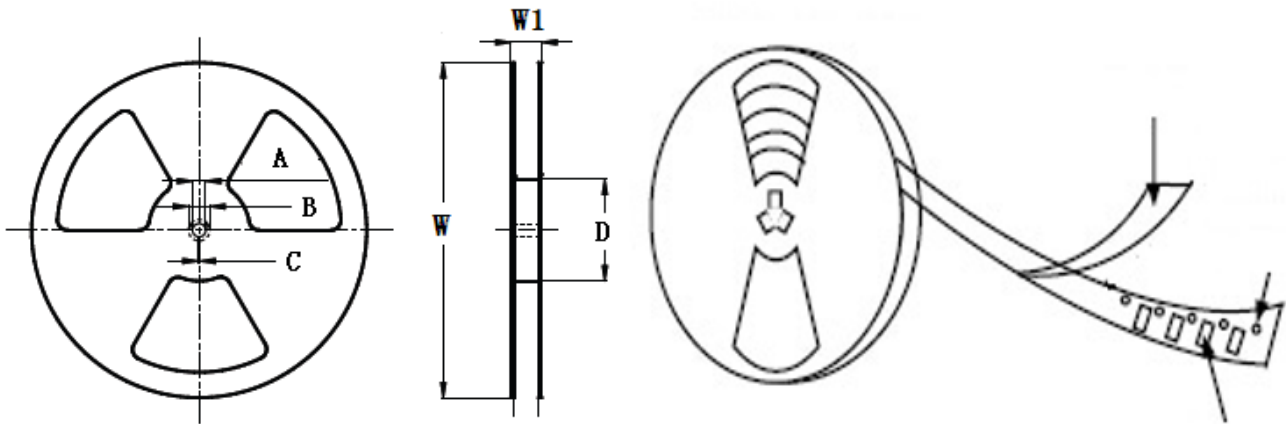

TYPE	W	W1	A	B	C	D
YLCM4532EL	178±2.0	8.40±1.50	4.3±0.20	5.0±0.10	3.0±0.10	58±2.0

Direction of rolling

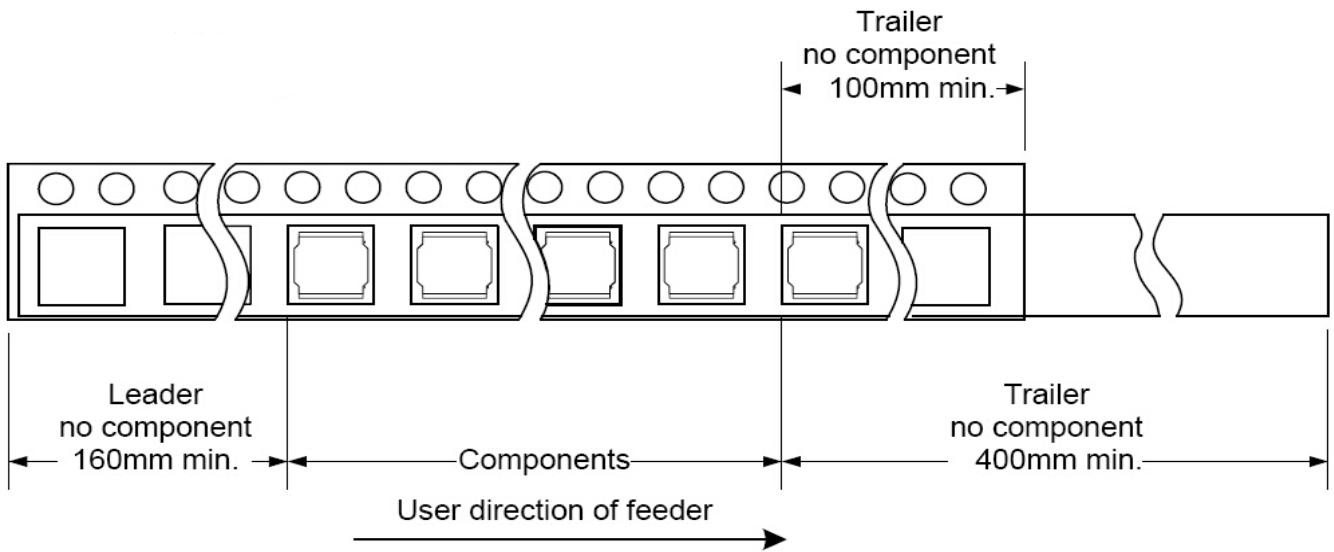

Cover tape peel off condition

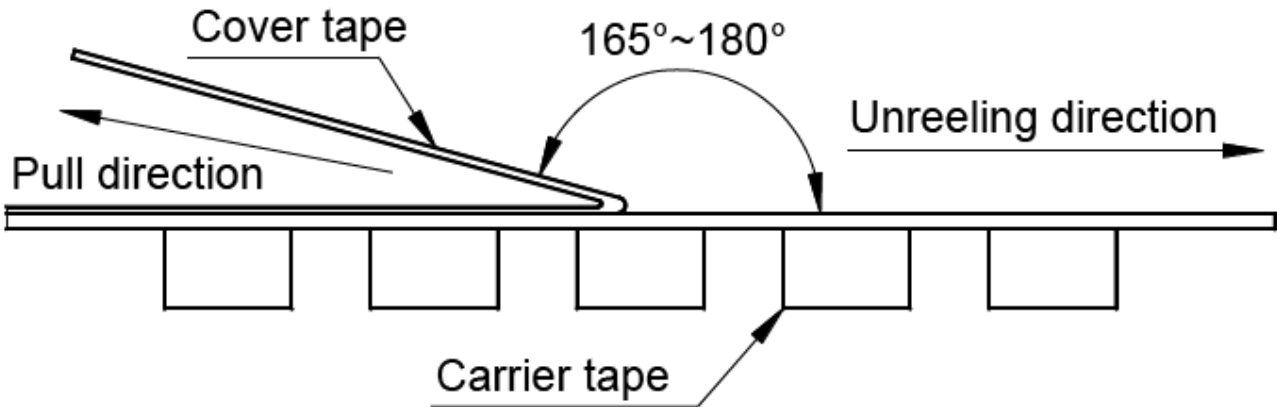

Cover tape peel force shall be 0.1N to 1.3N.

Reference peel speed 300±10mm/min.