

## High Current, Power Inductors

### FXLB252012-XXX-M Power Choke

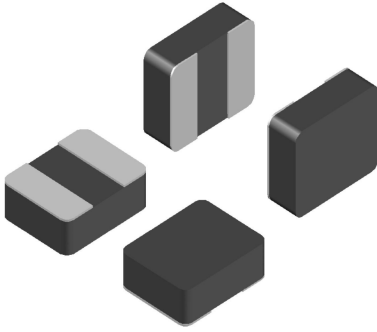

#### Description

- Halogen Free
- 125°C maximum total temperature operation
- 2.7 x2.2x 1.2mm maximum surface mount package
- Powder iron core material
- Magnetically shielded, low EMI
- High current carrying capacity, Low core losses
- RoHS compliant

#### Applications

- Voltage Regulator Module (VRM)
- Multi-phase regulators
- Point-of-load modules
- Smart phone POL modules
- SSD modules
- Notebook regulators
- Battery power systems
- Graphics cards
- Data networking and storage systems



#### Environmental Data

- Storage temperature range: -55°C to +125 °C
- Operating temperature range: -55°C to +125°C (ambient plus self-temperature rise)
- Solder reflow temperature: J-STD-020 compliant

Description													
FXLB252012-R33-M				0.33μH				±20 %					
Model				Inductance Value				Inductance Tolerance					
Global Part Number													
F	X	L	B	2	5	2	0	1	2	R	3	3	M
Product Series				Dimensions					Inductance Value			Tolerance	

Part No.	Inductance	DC Resistance		Heating Rating Current		Saturation Current	
	L0 (μH)	DCR (mΩ)		Idc (A)		Isat (A)	
	±20 %, 100 kHz, 1V	TYP.	MAX.	TYP.	MAX.	TYP.	MAX.
FXLB252012-R33-M	0.33	14.0	19.0	6.0	5.1	8.5	7.6
FXLB252012-R47-M	0.47	17.0	21.0	6.1	5.5	7.3	6.7
FXLB252012-R68-M	0.68	25.0	30.0	5.5	5.0	6.3	6.0
FXLB252012-1R0-M	1.0	35.0	42.0	4.2	3.9	5.4	5.0
FXLB252012-1R5-M	1.5	53.0	61.0	3.6	3.2	3.6	3.4
FXLB252012-2R2-M	2.2	68.0	82.0	3.0	2.7	3.3	3.0
FXLB252012-3R3-M	3.3	110.0	135.0	2.1	1.8	2.8	2.5
FXLB252012-4R7-M	4.7	160.0	190.0	1.8	1.5	2.4	2.1

**Notes**

1. All test data is referenced to 25 °C ambient
2. Operating temperature range - 55 °C to + 125 °C
3. Idc(A):DC current (A) that will cause an approximate ΔT of 40 °C(reference ambient temperature is 25 °C)
4. Isat(A):DC current (A) that will cause L0 to drop approximately 30 %
5. The part temperature (ambient + temp rise) should not exceed 125 °C under worst case operating conditions. Circuit design, component placement, PWB trace size and thickness, airflow and other cooling provisions all affect the part temperature. Part temperature should be verified in the end application.

**•Dimensions-mm**

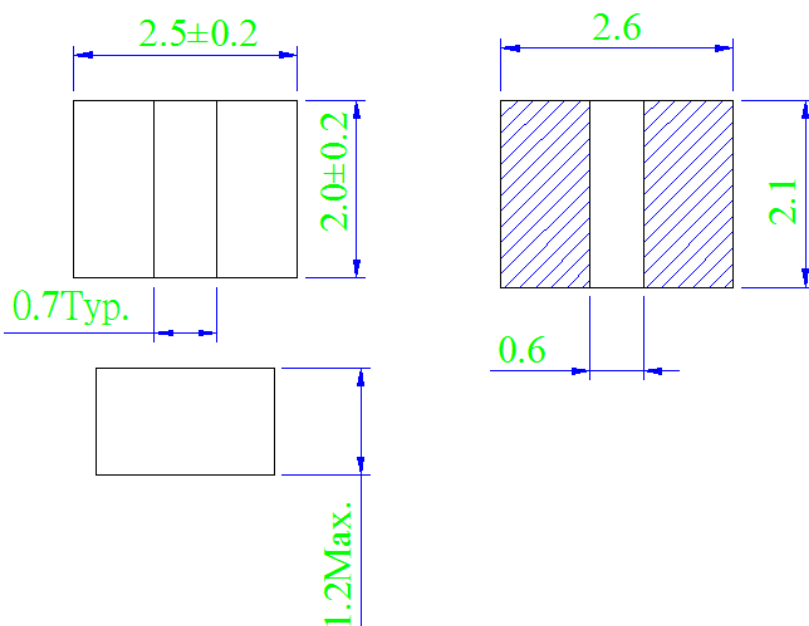

**• NO Marking**

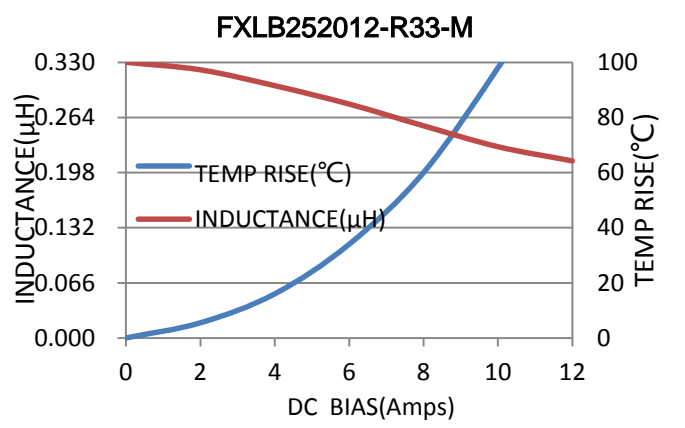
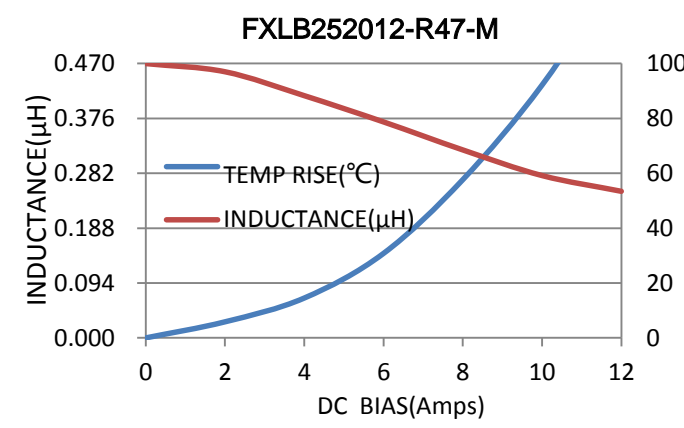
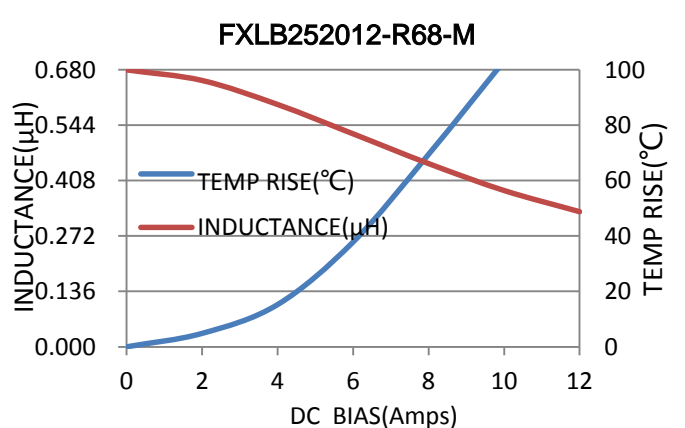
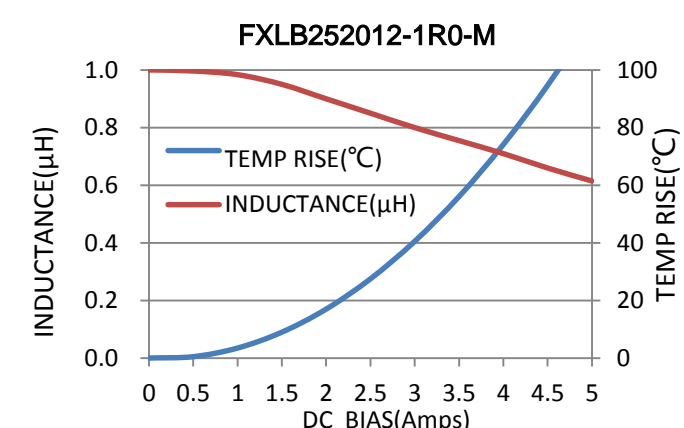
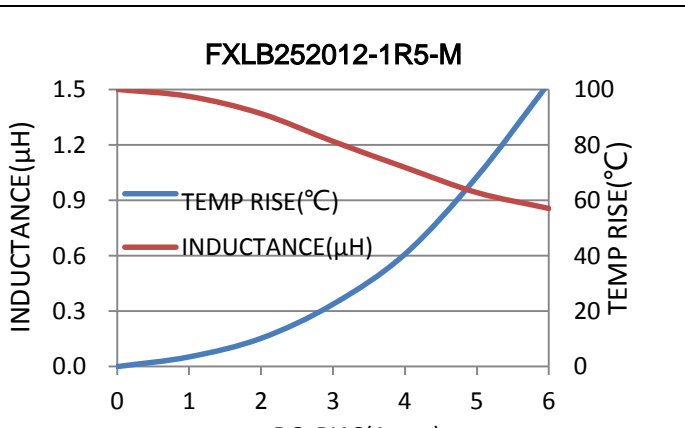
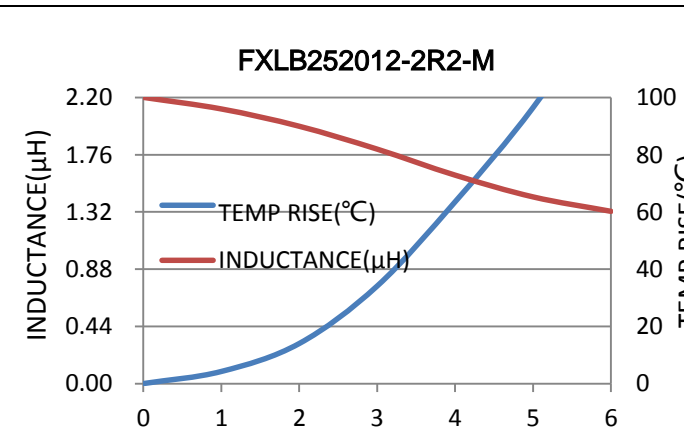
Performance Graphs	
Test Instruments	Test Condition
Wayne kerr 3260B/G LCR Meter Wayne kerr 3265B Bias Current Source	Temperature: 26 ± 3°C Humidity: < 70% RH Frequency: 100 KHz, 1.0V
<p><b>FXLB252012-R33-M</b></p> 	<p><b>FXLB252012-R47-M</b></p> 
<p><b>FXLB252012-R68-M</b></p> 	<p><b>FXLB252012-1R0-M</b></p> 
<p><b>FXLB252012-1R5-M</b></p> 	<p><b>FXLB252012-2R2-M</b></p> 

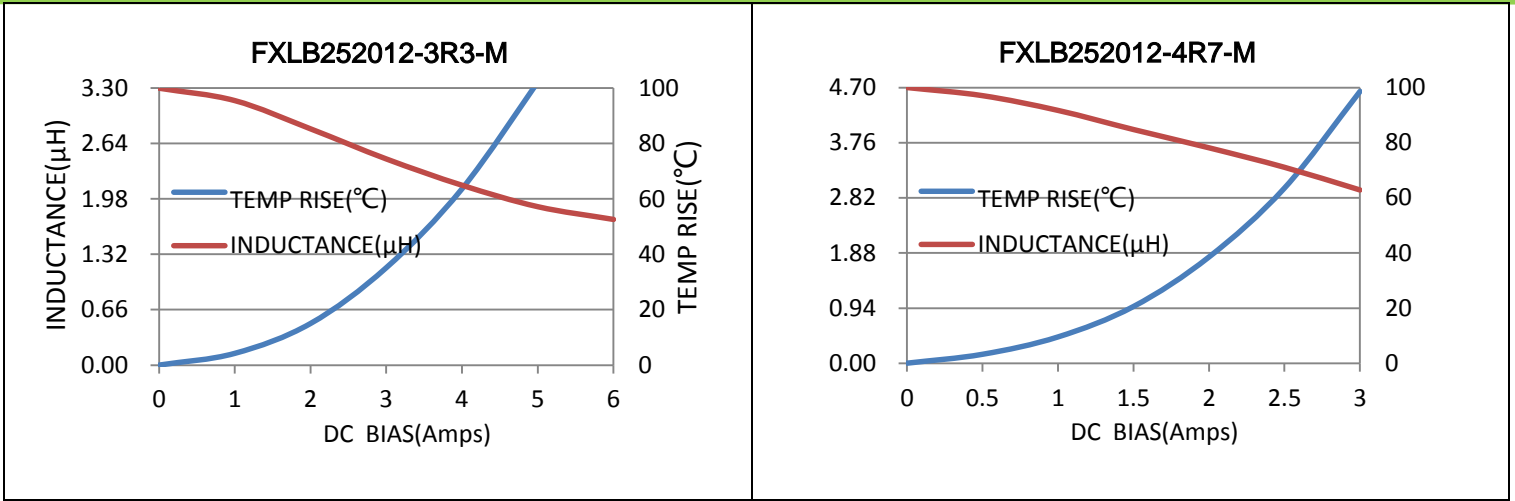

Mechanical Reliability		
Item	Specification and Requirement	Test Method
Solderability	The surface of terminal immersed shall be minimum of 95% covered with a new coating of solder	Solder heat proof: 1. Precondition: 8 hours steam aging 2. Retention time: 255 ± 5 °C for 5 ± 0.5 seconds
Vibration	Inductance change: Within ± 10% Without mechanical damage such as break	1. Vibration frequency:(10 Hz to 2000 Hz) 2. Vibration time:Each four hours (12 times) in X, Y, Z direction: 12 hours in total 3. Amplitude: 1mm or 10 G
Shock	Inductance change: Within ± 10% Without mechanical damage such as break	1. Peak value: 100 G 2. Duration of pulse: 6ms 3. Waveform: Half-sine Shocks; 3 times in X, Y, Z direction, 9 times in total
Endurance Reliability		
Item	Specification and Requirement	Test Method
Thermal Shock	Inductance change: Within ± 10% Without distinct damage in appearance	1. Repeat 1000 cycles as follow: (-55 ± 2 °C; 30 ± 3 min) → (+125 ± 2 °C, 30 ± 3 min) changeover time of temperature: ≤10s 2. Recovery: 24 + 4 / -0 hours of recovery under the standard condition after the test.
High Temperature & Humidity	Inductance change: Within ± 10% Without distinct damage in appearance	85°C 85%RH, Duration:240+4/-0 hours
Operational Life	Inductance change: Within ± 10% Without distinct damage in appearance	1.Rated current (Idc) Environment condition: 85 °C 2.Duration: 1000 + 4 / -0 hours
Low Temperature Store	Inductance change: Within ± 10% Without distinct damage in appearance	Store temperature: -55 ± 2 °C, 1000 + 4 / -0 hours
High Temperature Store	Inductance change: Within ± 10% Without distinct damage in appearance	Store temperature: +125 ± 2 °C, 1000 + 4 / -0 hours

Tape Packaging Dimensions

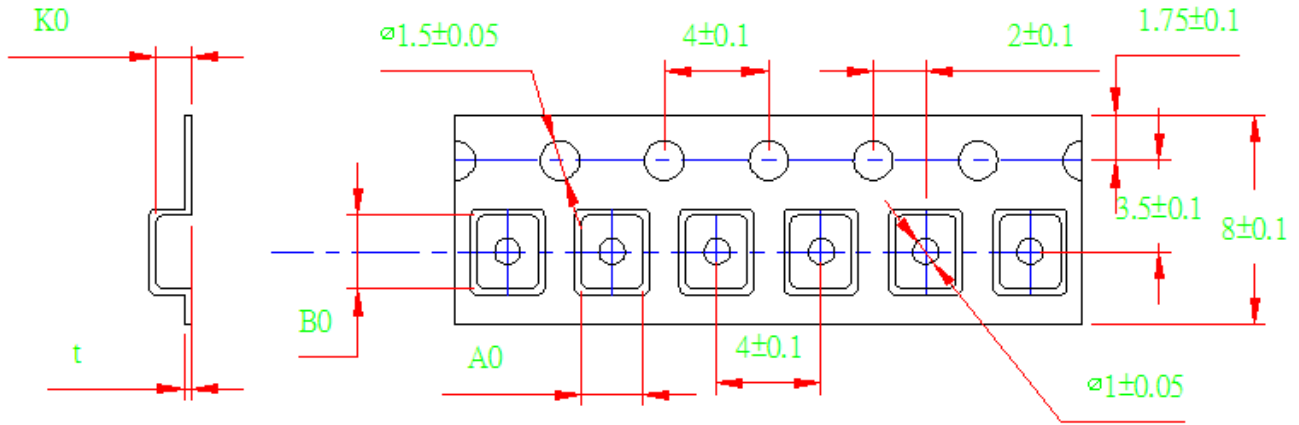

A0	B0	K0	t
$2.35 \pm 0.05$	$2.80 \pm 0.05$	$1.35 \pm 0.05$	$0.25 \pm 0.05$

Reel Dimensions

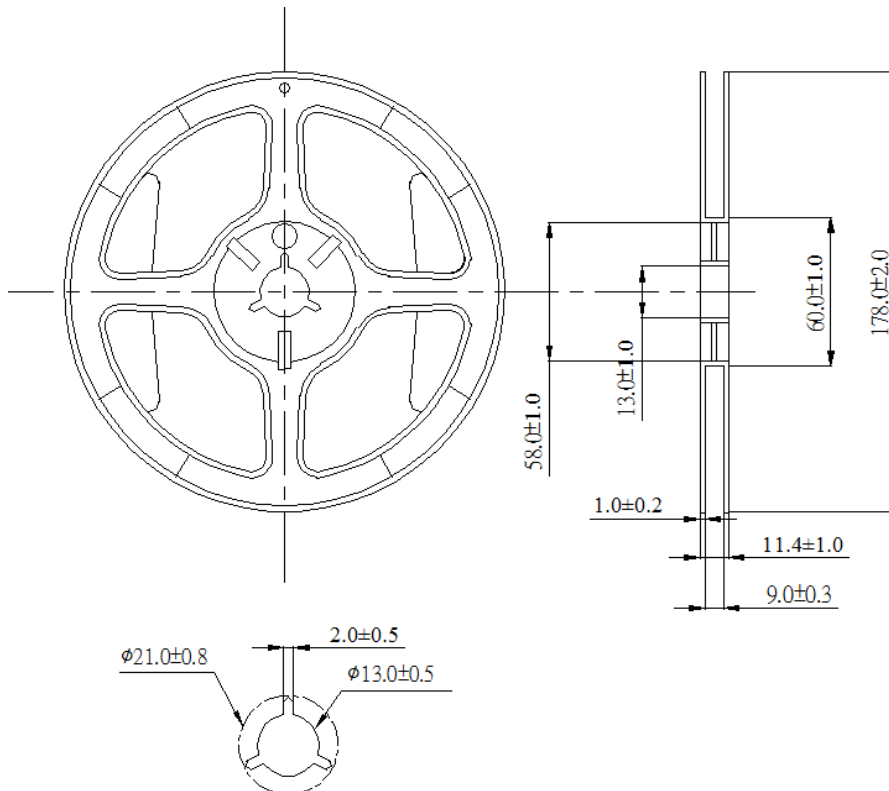

• Peel force of top cover tape

The peel speed shall be about 300mm/minute

The peel force of top cover tape shall be between 0.1 to 1.3 N

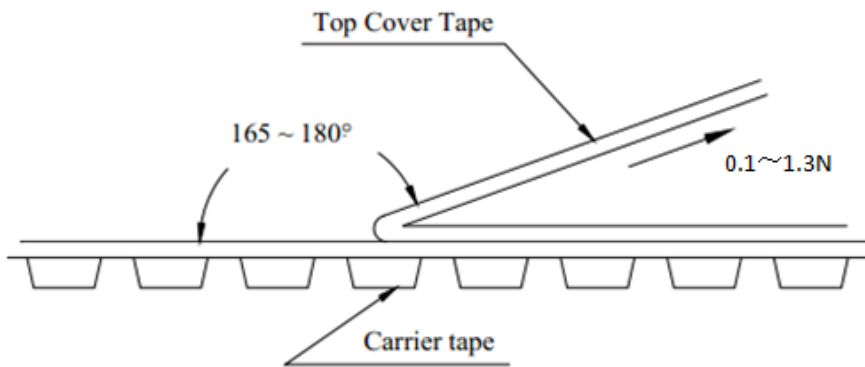

• Numbers of taping

3000pieces/reel