

RoHS

SPECIFICATIONS

Rated Current:1.5AMP
 Contact Resistance:20mΩ Max
 Withstand Voltage:400V AC/DC
 Insulation Resistance:800MΩ Min
 Operation Temperature:-40°C to +105°C

Contact Material:Brass
 Contact Plating:Au Over Ni
 Insulator Material:Polyester(UL94V-0)
 Standard: PA6T
 Max.Processing Temp: 230°C for 30-60 seconds
 (260°C for 10 seconds)

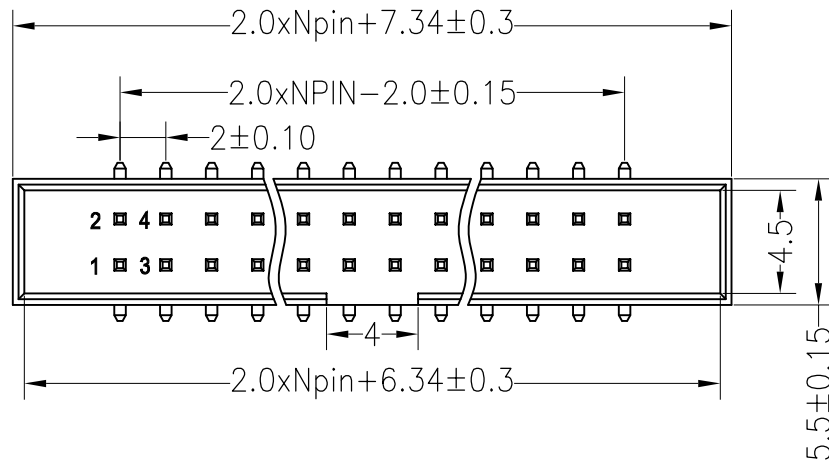

Recommended P.C.B Layout(Top Side)
 (PCB BOARD TOLERANCE ± 0.05)

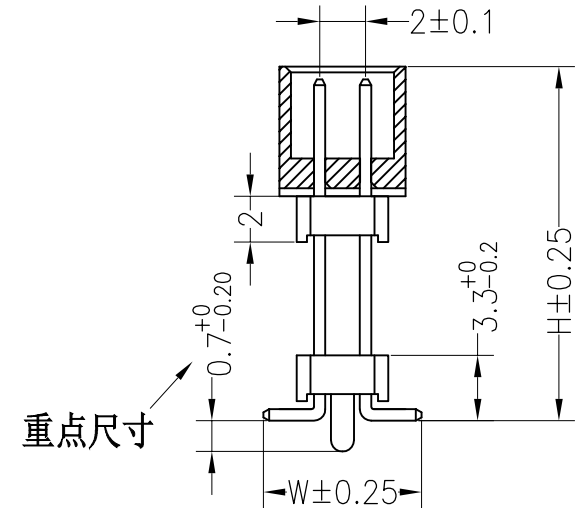
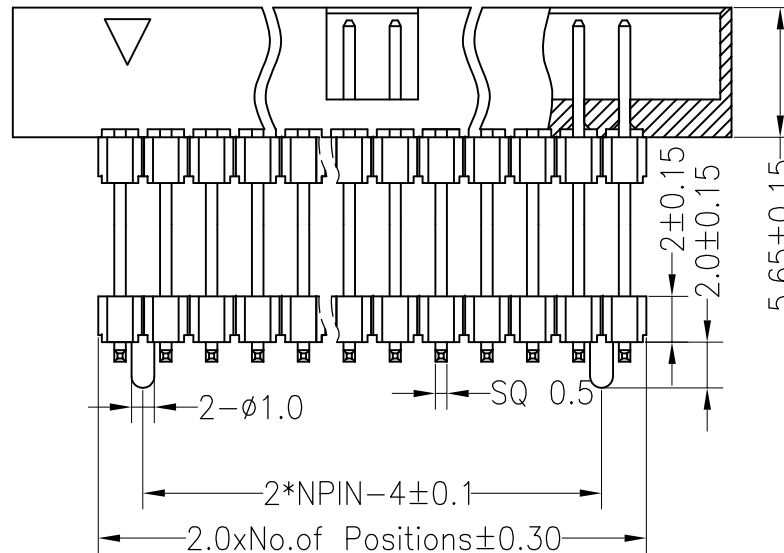
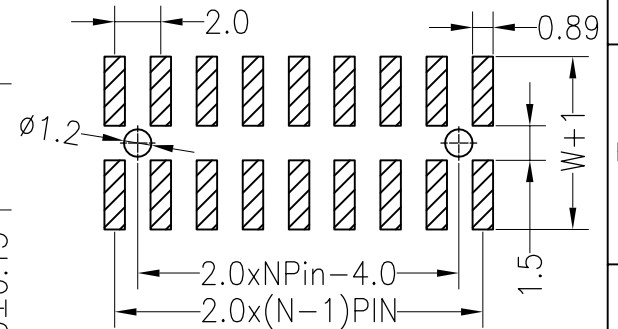

重点尺寸

Dimension antitheses list				
ITEM	D	W	PB	L
Alternate		6.50	16.90	18.00

				OPERATION		DRAW		SCALE		FIT		深圳市连盛精密连接器有限公司 PART NO. BH-00048 TITLE: 2.0Box 40P 3H=5.65+2X2.00 SMT=6.5 总高16.9			
				X.X	± 0.30			UNIT	mm						
				X.XX	± 0.20	CHECK		SIZE	A4						
A0				2012.03.28	NEW DRAWING				SHEET	1/1					
REV	DATE	MODIFICATION DESCRIPTION		CHANGE	Angle	$\pm 3'$	APPROVE		PROJ.	ϕ					
1	2	3	4	5	6	7	8	9							