

REV.	ECN NO.	MODIFY MATTER	DATE	APPROVED
A		RELEASE TO PRODUCTION		

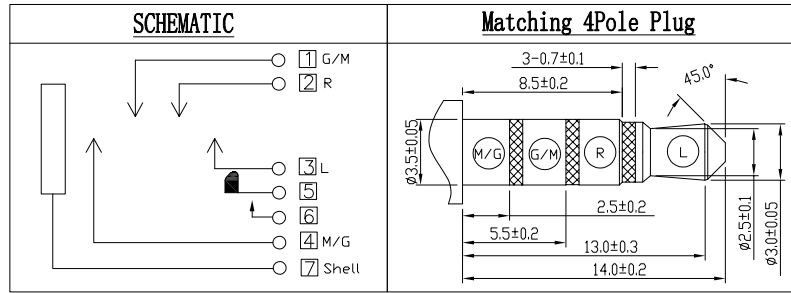

- SPECIFICATION**
1. Rating : DC 30V 0.5A;
 2. Contact resistance: $\leq 30m\Omega$;
 3. Insulation resistance: $\geq 100M\Omega$ (DC250V);
 4. Withstand voltage: 500VAC ;
 5. Insertion and extraction force: 3-30N;
 6. life test: 5,000 cycles.

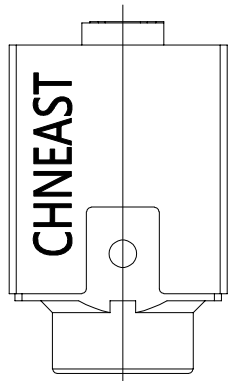
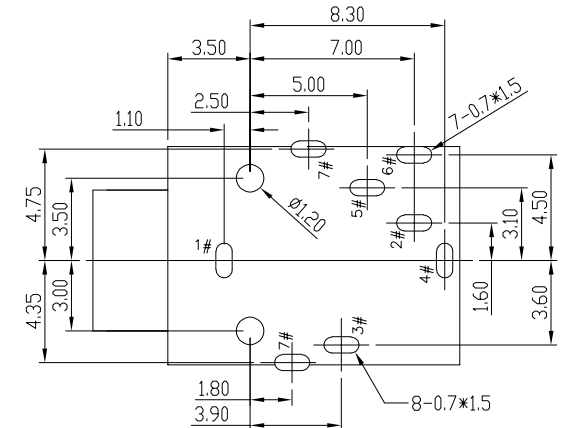
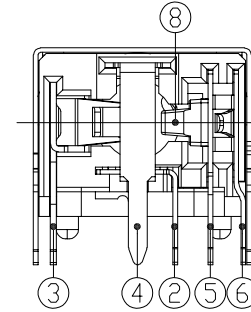
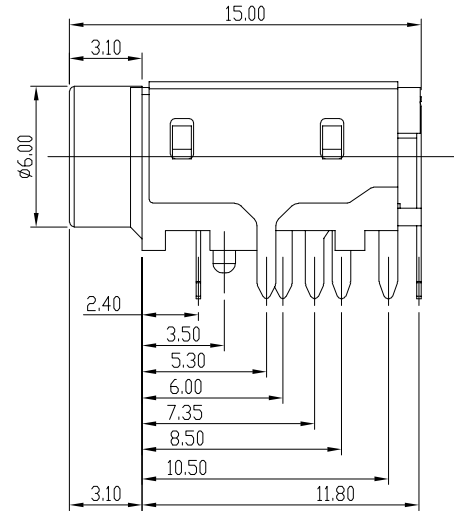
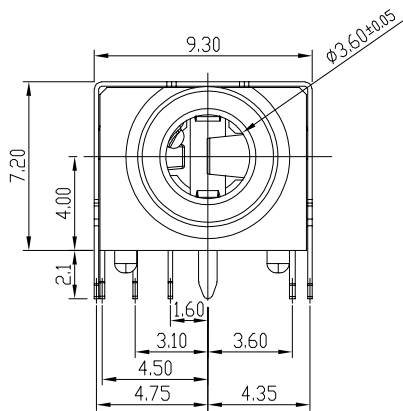

P.C.B LAYOUT TOP VIEW

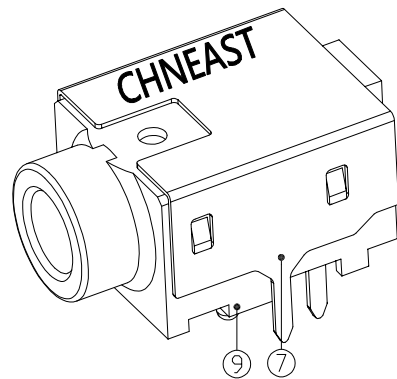
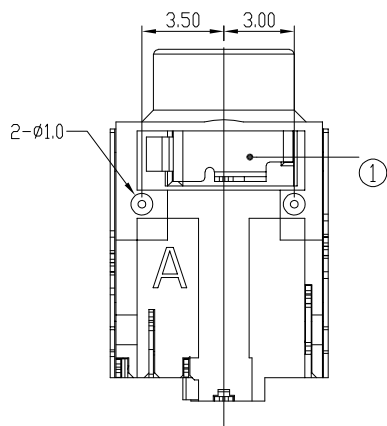

NO.	DESCRIPTION	QTY	MATERIAL	PLATING
9	HOUSING	1	PA9T	Black
8	INSULATOR	1	PA9T	Black
7	SHELL	1	SUS301 T=0.20mm	NI-Plating
6	TERMINAL-6	1	COPPER ALLOY T=0.20mm	Matte Sn-Plating
5	TERMINAL-5	1	COPPER ALLOY T=0.20mm	Matte Sn-Plating
4	TERMINAL-4	1	COPPER ALLOY T=0.20mm	Matte Sn-Plating
3	TERMINAL-3	1	COPPER ALLOY T=0.25mm	Matte Sn-Plating
2	TERMINAL-2	1	COPPER ALLOY T=0.20mm	Matte Sn-Plating
1	TERMINAL-1	1	COPPER ALLOY T=0.20mm	Matte Sn-Plating

TOLERANCES UNLESS OTHERWISE SPECIFIED:
X. ---
X.X ± 0.38
X.XX ± 0.25
X.XXX ± 0.20
Angle ± 3°

CUSTOMER COPY

深圳市东方御业科技有限公司
WWW.DFYCONN.COM TEL:0755-27155560

TABLE:

COLOR	PART No.
BLACK	EAST-2339J-08DB-PPA
PINK(#199C)	EAST-2339J-08DP-PPA
GREEN(#577C)	EAST-2339J-08DG-PPA

THESE DRAWING AND SPECIFICATION ARE THE PROPERTY OF ShenzhenDongfangyue ELECTRONIC CO., LTD.. SHALL NOT BE REPRODUCED.

DRAWN:

Qinx

Chenl

Chenl

2017/09/10

2017/09/10

2017/09/10

TITL:

0.3.5mm PHONE JACK

PART NO:

EAST-2339J-08DX-PPA

UNIT:

mm

DRAWING NO:

(RoHS)

SCALE:

N/A

SHEET:

REV.

REV.	ECN NO.	MODIFY	MATTER	DATE	APPROVED
A		RELEASE TO PRODUCTION			

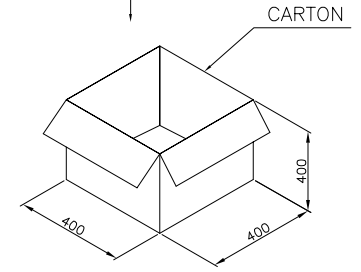
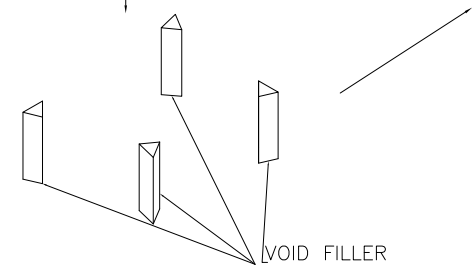
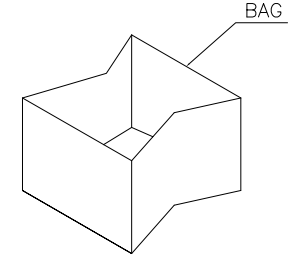
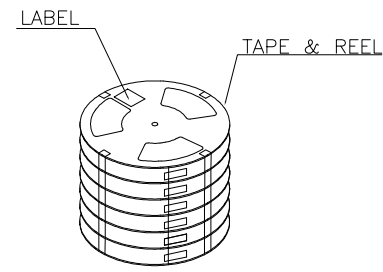
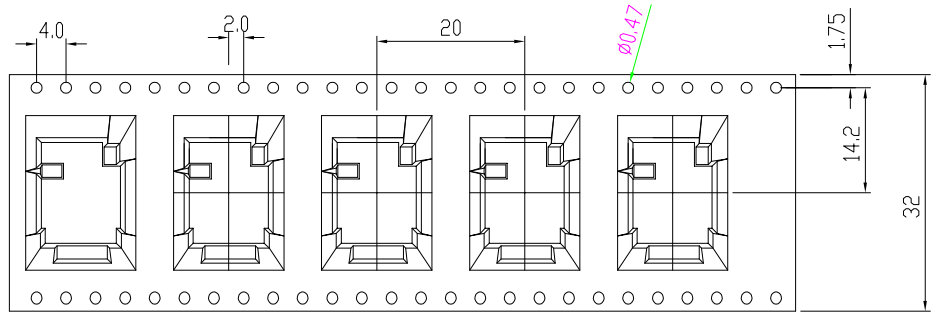
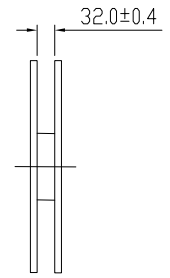
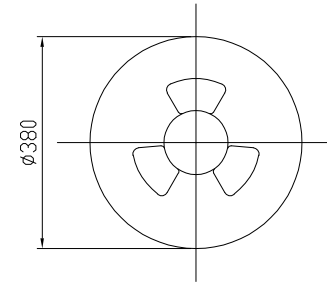
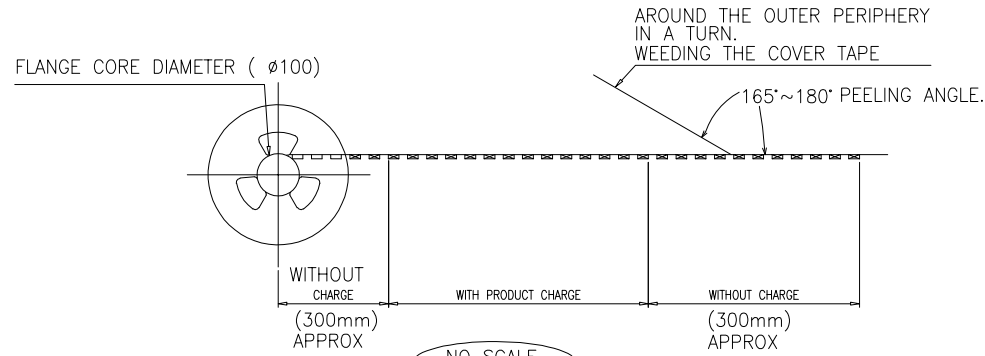

NOTES :
 PACKAGING MATERIAL IN PLASTIC, RUBBER, INK, PIGMENT AND PAINT
 MUST MEET CONTROLLED SUBSTANCES SPEC PER 230-702.

- * CADMIUM AND CADMIUM COMPOUNDS NOT TO EXCEED:
5 PPM.
- * LEAD, CADMIUM, CHROM VI AND MERCURY NOT TO EXCEED:
100 PPM (COMBINED).
- * CARRIER TAPES, COVER TAPES,
REELS AND TAPED COMPONENTS MUST
MEET THE REQUIREMENTS DEFINED PER EIA-481-B.

- MATERIAL :
COVER TAPE : PET
CARRIER TAPE : PS
REEL : PS
SHIPPING BOX: CORRUGATED FIBER
- DIMENSION :
REEL : SEE DRAWING
BOX : SEE DRAWING
- QUANTITY : SEE TABLE
- WEIGHT : SEE TABLE
- PEELING RESISTANCE : 10gf~100gf (for 8mm)
- PEELING SPEED : 300mm/MINUTES

QUANTITY:
 500 PCS/REEL
 10 REELS/INNER BOX: 5000PCS

TOLERANCES UNLESS OTHERWISE SPECIFIED: X. --- X.X ± 0.38 X.XX ± 0.25 X.XXX ± 0.20 Angle ± 3°	CUSTOMER COPY	深圳市东方御业科技有限公司 WWW.DFYCONN.COM TEL:0755-27155560			
	DRAWN: Qinx	2017/09/10	TITIAL: Ø3.5mm PHONE JACK		
THESE DRAWING AND SPECIFICATION ARE THE PROPERTY OF ShenzhenDongfangyuye ELECTRONIC CO., LTD.; SHALL NOT BE REPRODUCED.	CHECKED: Chenl	2017/09/10	PART NO: EAST-2339J-08DX-PPA	DRAWING NO: (RoHS)	
	APPROVED: Chenl	2017/09/10	UNIT: mm	SCALE: N/A	SHEEL: REV.