

Features

- Low power consumption
- Low voltage drop
- Low temperature coefficient
- High input voltage (up to 28V)
- Output voltage accuracy: tolerance $\pm 2\%$
- TO92, SOT89, SOT23-3, SOT23-5 package

Applications

- Battery-powered equipment
- Communication equipment
- Audio/Video equipment

General Description

The HT75XX-1 series is a set of three-terminal low power high voltage regulators implemented in CMOS technology. They allow input voltages as high as 28V. They are available with several fixed output voltages ranging from 2.1V to 5.0V. CMOS technology ensures low voltage drop and low quiescent current. Although designed primarily as fixed voltage regulators, these devices can be used with external components to obtain variable voltages and currents.

Selection Table

Part No.	Output Voltage	Package	Marking
HT7121	2.1V	TO92 SOT89 SOT23-3	71XXA-1(for TO92) 71XX-1(for SOT89) HTXX(for SOT23-3)
HT7123	2.3V		
HT7125	2.5V		
HT7127	2.7V		
HT7130	3.0V		
HT7133	3.3V		
HT7136	3.6V		
HT7140	4.0V		
HT7144	4.4V		
HT7150	5.0V		

Block Diagram

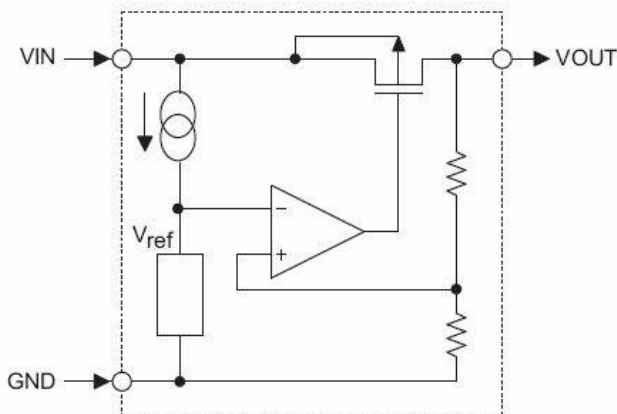

Pin Assignment

HT71XX-1
100mA Low Power LDO

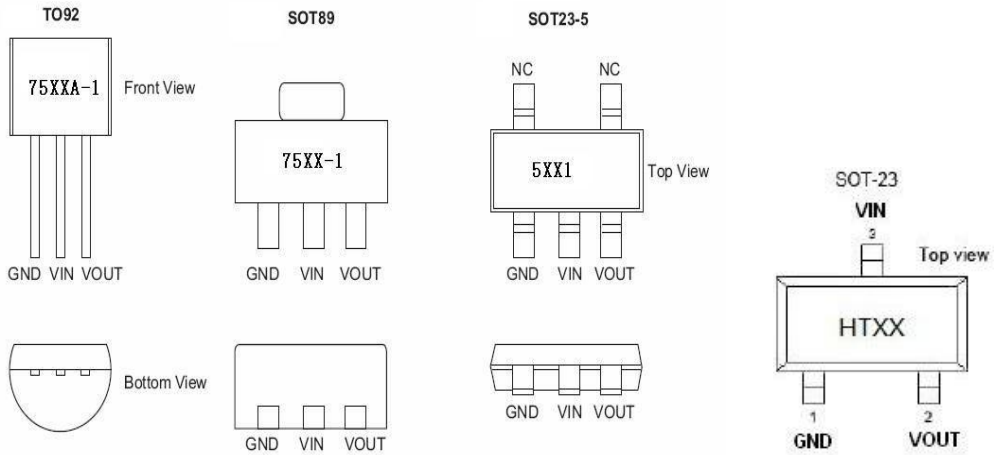

Absolute Maximum Ratings

Supply Voltage-0.3V to 28V Storage Temperature-50°C to 125°C
 Operating Temperature-40°C to 85°C

Note: These are stress ratings only. Stresses exceeding the range specified under “Absolute Maximum Ratings” may cause substantial damage to the device. Functional operation of this device at other conditions beyond those listed in the specification is not implied and prolonged exposure to extreme conditions may affect device reliability.

Thermal Information

Symbol	Parameter	Package	Max.	Unit
θ_{JA}	Thermal Resistance (Junction to Ambient) (Assume no ambient airflow, no heat sink)	SOT23-3	500	°C/W
		SOT89	200	°C/W
		TO92	200	°C/W
P_D	Power Dissipation	SOT23-3	0.20	W
		SOT89	0.50	W
		TO92	0.50	W

Note: P_D is measured at $T_a = 25^\circ\text{C}$

Electrical Characteristics

HT7121-1, +2.1V Output Type

Symbol	Parameter	Test Conditions		Min.	Typ.	Max.	Unit
		V _{IN}	Conditions				
V _{OUT}	Output Voltage	4.1V	I _{OUT} =10mA	2.037	2.100	2.163	V
I _{OUT}	Output Current	4.1V	-	20	30	-	mA
ΔV _{OUT}	Load Regulation	4.1V	1mA ≤ I _{OUT} ≤ 20mA	-	60	100	mV
V _{DIF}	Voltage Drop(Note)	-	I _{OUT} =1mA, ΔV _{OUT} =2%	-	100	-	mV
ISS	Current Consumption	4.1V	No load	-	2.5	5.0	μA
$\frac{\Delta V_{OUT}}{\Delta V_{IN} \times \Delta V_{OUT}}$	Line Regulation	-	3.1V ≤ V _{IN} ≤ 18V I _{OUT} =1mA	-	0.2	-	%/V
V _{IN}	Input Voltage	-	-	-	-	28	V
$\frac{\Delta V_{OUT}}{\Delta T_a}$	Temperature Coefficient	4.1V	I _{OUT} =10mA 0°C < T _a < 70°C	-	±0.37	-	mV/°C

Note: Dropout voltage is defined as the input voltage minus the output voltage that produces a 2% change in the output voltage from the value at V_{IN} = V_{OUT}+2V with a fixed load.

HT7123-1, +2.3V Output Type

Symbol	Parameter	Test Conditions		Min.	Typ.	Max.	Unit
		V _{IN}	Conditions				
V _{OUT}	Output Voltage	4.3V	I _{OUT} =10mA	2.231	2.300	2.369	V
I _{OUT}	Output Current	4.3V	-	20	30	-	mA
ΔV _{OUT}	Load Regulation	4.3V	1mA ≤ I _{OUT} ≤ 20mA	-	60	100	mV
V _{DIF}	Voltage Drop(Note)	-	I _{OUT} =1mA, ΔV _{OUT} =2%	-	100	-	mV
ISS	Current Consumption	4.3V	No load	-	2.5	5.0	μA
$\frac{\Delta V_{OUT}}{\Delta V_{IN} \times \Delta V_{OUT}}$	Line Regulation	-	3.3V ≤ V _{IN} ≤ 18V I _{OUT} =1mA	-	0.2	-	%/V
V _{IN}	Input Voltage	-	-	-	-	28	V

HT71XX-1

100mA Low Power LDO

$\frac{\Delta V_{OUT}}{\Delta T_a}$	Temperature Coefficient	4.3V	I _{OUT} =10mA 0°C<T _a <70°C	-	±0.39	-	mV/°C
-------------------------------------	-------------------------	------	--	---	-------	---	-------

Note: Dropout voltage is defined as the input voltage minus the output voltage that produces a 2% change in the output voltage from the value at V_{IN} = V_{OUT}+2V with a fixed load.

HT7125-1, +2.5V Output Type

Symbol	Parameter	Test Conditions		Min.	Typ.	Max.	Unit
		V _{IN}	Conditions				
V _{OUT}	Output Voltage	4.5V	I _{OUT} =10mA	2.425	2.500	2.575	V
I _{OUT}	Output Current	4.5V	-	20	30	-	mA
Δ V _{OUT}	Load Regulation	4.5V	1mA ≤ I _{OUT} ≤ 20mA	-	60	100	mV
V _{DIF}	Voltage Drop(Note)	-	I _{OUT} =1mA, Δ V _{OUT} =2%	-	100	-	mV
ISS	Current Consumption	4.5V	No load	-	2.5	5.0	μ A
$\frac{\Delta V_{OUT}}{\Delta V_{IN} \times \Delta V_{OUT}}$	Line Regulation	-	3.5V ≤ V _{IN} ≤ 18V I _{OUT} =1mA	-	0.2	-	%/V
V _{IN}	Input Voltage	-	-	-	-	28	V
$\frac{\Delta V_{OUT}}{\Delta T_a}$	Temperature Coefficient	4.5V	I _{OUT} =10mA 0°C<T _a <70°C	-	±0.41	-	mV/°C

Note: Dropout voltage is defined as the input voltage minus the output voltage that produces a 2% change in the output voltage from the value at V_{IN} = V_{OUT}+2V with a fixed load.

HT7527-1, +2.7V Output Type

Symbol	Parameter	Test Conditions		Min.	Typ.	Max.	Unit
		V _{IN}	Conditions				
V _{OUT}	Output Voltage	4.7V	I _{OUT} =10mA	2.619	2.700	2.781	V
I _{OUT}	Output Current	4.7V	-	20	30	-	mA
Δ V _{OUT}	Load Regulation	4.7V	1mA ≤ I _{OUT} ≤ 20mA	-	60	100	mV
V _{DIF}	Voltage Drop(Note)	-	I _{OUT} =1mA, Δ V _{OUT} =2%	-	100	-	mV
ISS	Current Consumption	4.7V	No load	-	2.5	5.0	μ A
$\frac{\Delta V_{OUT}}{\Delta V_{IN} \times \Delta V_{OUT}}$	Line Regulation	-	3.7V ≤ V _{IN} ≤ 18V I _{OUT} =1mA	-	0.2	-	%/V
V _{IN}	Input Voltage	-	-	-	-	28	V

HT71XX-1

100mA Low Power LDO

$\frac{\Delta V_{OUT}}{\Delta T_a}$	Temperature Coefficient	4.7V	I _{OUT} =10mA 0°C<T _a <70°C	-	±0.43	-	mV/°C
-------------------------------------	-------------------------	------	--	---	-------	---	-------

Note: Dropout voltage is defined as the input voltage minus the output voltage that produces a 2% change in the output voltage from the value at V_{IN} = V_{OUT}+2V with a fixed load.

HT7130-1, +2.1V Output Type

Symbol	Parameter	Test Conditions		Min.	Typ.	Max.	Unit
		V _{IN}	Conditions				
V _{OUT}	Output Voltage	5V	I _{OUT} =10mA	2.91	3.00	2.09	V
I _{OUT}	Output Current	5V	-	20	30	-	mA
ΔV _{OUT}	Load Regulation	5V	1mA ≤ I _{OUT} ≤ 20mA	-	60	100	mV
V _{DIF}	Voltage Drop(Note)	-	I _{OUT} =1mA, ΔV _{OUT} =2%	-	100	-	mV
ISS	Current Consumption	5V	No load	-	2.5	5.0	μA
$\frac{\Delta V_{OUT}}{\Delta V_{IN} \times \Delta V_{OUT}}$	Line Regulation	-	4V ≤ V _{IN} ≤ 18V I _{OUT} =1mA	-	0.2	-	%/V
V _{IN}	Input Voltage	-	-	-	-	28	V
$\frac{\Delta V_{OUT}}{\Delta T_a}$	Temperature Coefficient	5V	I _{OUT} =10mA 0°C<T _a <70°C	-	±0.45	-	mV/°C

Note: Dropout voltage is defined as the input voltage minus the output voltage that produces a 2% change in the output voltage from the value at V_{IN} = V_{OUT}+2V with a fixed load.

HT7133-1, +3.3V Output Type

Symbol	Parameter	Test Conditions		Min.	Typ.	Max.	Unit
		V _{IN}	Conditions				
V _{OUT}	Output Voltage	5.5V	I _{OUT} =10mA	3.201	3.300	3.399	V
I _{OUT}	Output Current	5.5V	-	20	30	-	mA
ΔV _{OUT}	Load Regulation	5.5V	1mA ≤ I _{OUT} ≤ 20mA	-	60	100	mV
V _{DIF}	Voltage Drop(Note)	-	I _{OUT} =1mA, ΔV _{OUT} =2%	-	100	-	mV
ISS	Current Consumption	5.5V	No load	-	2.5	5.0	μA
$\frac{\Delta V_{OUT}}{\Delta V_{IN} \times \Delta V_{OUT}}$	Line Regulation	-	4.5V ≤ V _{IN} ≤ 18V I _{OUT} =1mA	-	0.2	-	%/V

HT71XX-1 100mA Low Power LDO

V_{IN}	Input Voltage	-	-	-	-	28	V
$\frac{\Delta V_{OUT}}{\Delta T_a}$	Temperature Coefficient	5.5V	I _{OUT} =10mA 0°C<T _a <70°C	-	±0.5	-	mV/°C

Note: Dropout voltage is defined as the input voltage minus the output voltage that produces a 2% change in the output voltage from the value at $V_{IN} = V_{OUT}+2V$ with a fixed load.

HT7136-1, +3.6V Output Type

Symbol	Parameter	Test Conditions		Min.	Typ.	Max.	Unit
		V_{IN}	Conditions				
V_{OUT}	Output Voltage	5.6V	I _{OUT} =10mA	3.492	3.600	3.708	V
I _{OUT}	Output Current	5.6V	-	20	30	-	mA
ΔV_{OUT}	Load Regulation	5.6V	1mA ≤ I _{OUT} ≤ 20mA	-	60	100	mV
V_{DIF}	Voltage Drop(Note)	-	I _{OUT} =1mA, ΔV_{OUT} =2%	-	100	-	mV
ISS	Current Consumption	5.6V	No load	-	2.5	5.0	μA
$\frac{\Delta V_{OUT}}{\Delta V_{IN} \times \Delta V_{OUT}}$	Line Regulation	-	4.6V ≤ V_{IN} ≤ 18V I _{OUT} =1mA	-	0.2	-	%/V
V_{IN}	Input Voltage	-	-	-	-	28	V
$\frac{\Delta V_{OUT}}{\Delta T_a}$	Temperature Coefficient	5.6V	I _{OUT} =10mA 0°C<T _a <70°C	-	±0.6	-	mV/°C

Note: Dropout voltage is defined as the input voltage minus the output voltage that produces a 2% change in the output voltage from the value at $V_{IN} = V_{OUT}+2V$ with a fixed load.

HT7140-1, +4.0V Output Type

Symbol	Parameter	Test Conditions		Min.	Typ.	Max.	Unit
		V_{IN}	Conditions				
V_{OUT}	Output Voltage	6V	I _{OUT} =10mA	3.88	4	4.12	V
I _{OUT}	Output Current	6V	-	60	100	-	mA
ΔV_{OUT}	Load Regulation	6V	1mA ≤ I _{OUT} ≤ 50mA	-	60	150	mV
V_{DIF}	Voltage Drop(Note)	-	I _{OUT} =1mA, ΔV_{OUT} =2%	-	100	-	mV
ISS	Current Consumption	6V	No load	-	2.5	5.0	μA

HT71XX-1

100mA Low Power LDO

$\frac{\Delta V_{OUT}}{\Delta V_{IN} \times \Delta V_{OUT}}$	Line Regulation	-	$5V \leq V_{IN} \leq 18V$ $I_{OUT}=1mA$	-	0.2	-	%/V
V_{IN}	Input Voltage	-	-	-	-	28	V
$\frac{\Delta V_{OUT}}{\Delta Ta}$	Temperature Coefficient	5.6V	$I_{OUT}=10mA$ $0^{\circ}C < Ta < 70^{\circ}C$	-	± 0.7	-	mV/°C

Note: Dropout voltage is defined as the input voltage minus the output voltage that produces a 2% change in the output voltage from the value at $V_{IN} = V_{OUT} + 2V$ with a fixed load.

HT7144-1, +4.4V Output Type

Symbol	Parameter	Test Conditions		Min.	Typ.	Max.	Unit
		V_{IN}	Conditions				
V_{OUT}	Output Voltage	6.4V	$I_{OUT}=10mA$	4.268	4.400	4.532	V
I_{OUT}	Output Current	6.4V	-	20	30	-	mA
ΔV_{OUT}	Load Regulation	6.4V	$1mA \leq I_{OUT} \leq 20mA$	-	60	100	mV
V_{DIF}	Voltage Drop(Note)	-	$I_{OUT}=1mA, \Delta V_{OUT}=2\%$	-	100	-	mV
ISS	Current Consumption	6.4V	No load	-	2.5	5.0	μA
$\frac{\Delta V_{OUT}}{\Delta V_{IN} \times \Delta V_{OUT}}$	Line Regulation	-	$5.4V \leq V_{IN} \leq 18V$ $I_{OUT}=1mA$	-	0.2	-	%/V
V_{IN}	Input Voltage	-	-	-	-	28	V
$\frac{\Delta V_{OUT}}{\Delta Ta}$	Temperature Coefficient	6.4V	$I_{OUT}=10mA$ $0^{\circ}C < Ta < 70^{\circ}C$	-	± 0.7	-	mV/°C

Note: Dropout voltage is defined as the input voltage minus the output voltage that produces a 2% change in the output voltage from the value at $V_{IN} = V_{OUT} + 2V$ with a fixed load.

HT71XX-1

100mA Low Power LDO

HT7150-1, +5.0V Output Type

Symbol	Parameter	Test Conditions		Min.	Typ.	Max.	Unit
		V _{IN}	Conditions				
V _{OUT}	Output Voltage	7V	I _{OUT} =10mA	4.85	5.00	5.15	V
I _{OUT}	Output Current	7V	-	20	30	-	mA
ΔV _{OUT}	Load Regulation	7V	1mA ≤ I _{OUT} ≤ 20mA	-	60	100	mV
V _{DIF}	Voltage Drop(Note)	-	I _{OUT} =1mA, ΔV _{OUT} =2%	-	100	-	mV
I _{SS}	Current Consumption	7V	No load	-	2.5	5.0	μA
$\frac{\Delta V_{OUT}}{\Delta V_{IN} \times \Delta V_{OUT}}$	Line Regulation	-	6V ≤ V _{IN} ≤ 18V I _{OUT} =1mA	-	0.2	-	%/V
V _{IN}	Input Voltage	-	-	-	-	28	V
$\frac{\Delta V_{OUT}}{\Delta T_a}$	Temperature Coefficient	7V	I _{OUT} =10mA 0°C < T _a < 70°C	-	±0.75	-	mV/°C

Note: Dropout voltage is defined as the input voltage minus the output voltage that produces a 2% change in the output voltage from the value at V_{IN} = V_{OUT}+2V with a fixed load.

Application Circuits

Basic Circuits

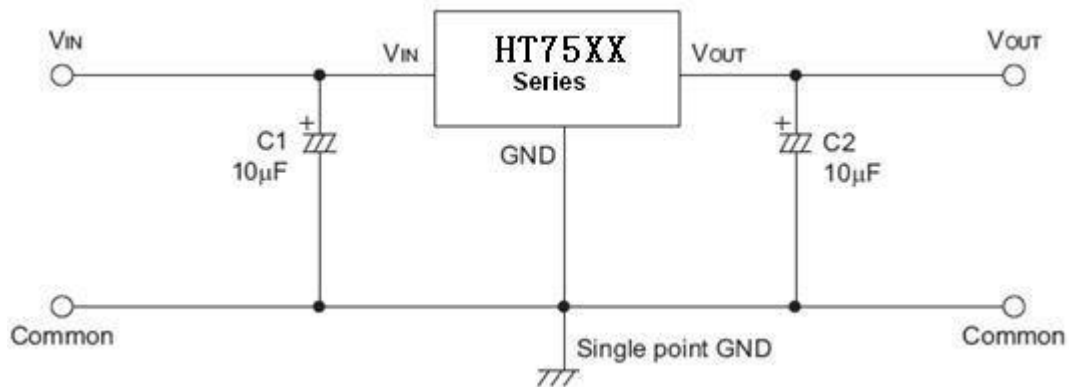

High Output Current Positive Voltage Regulator

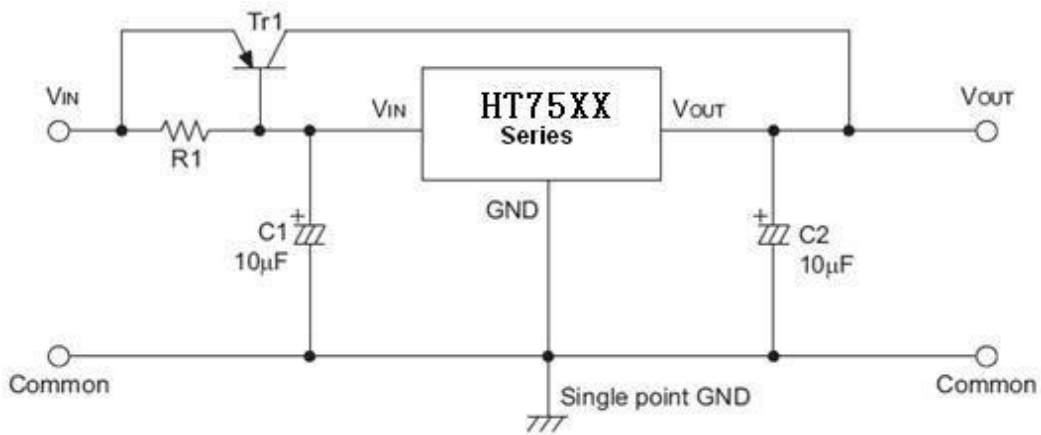

Short-Circuit Protection by Tr1

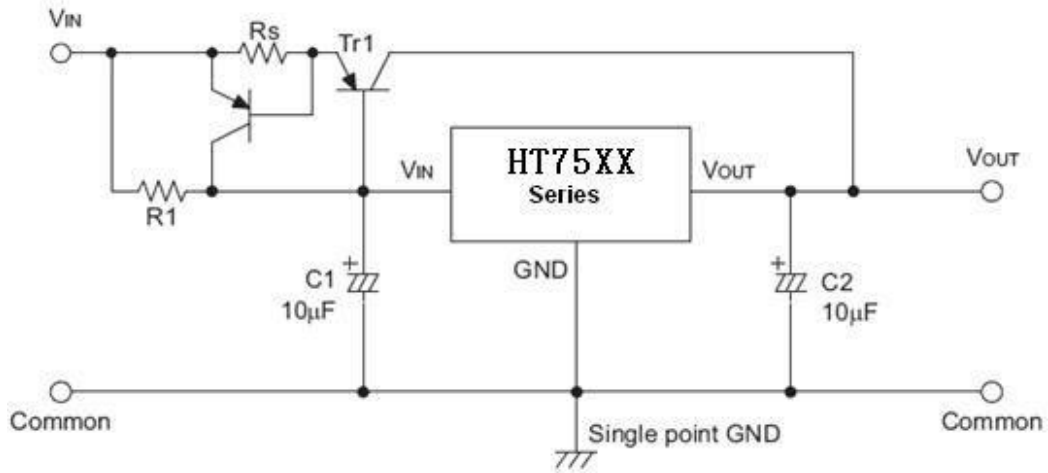

Circuit for Increasing Output Voltage

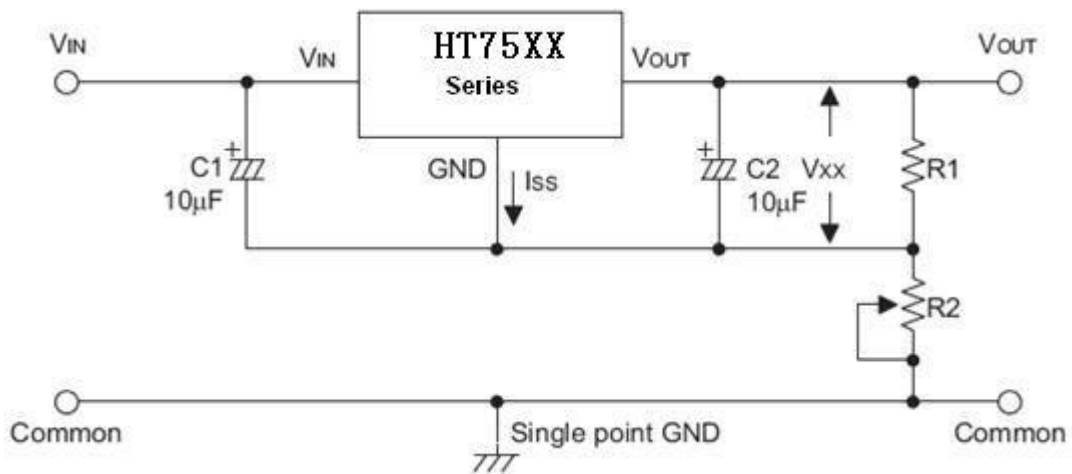

Circuit for Increasing Output Voltage

HT71XX-1
100mA Low Power LDO

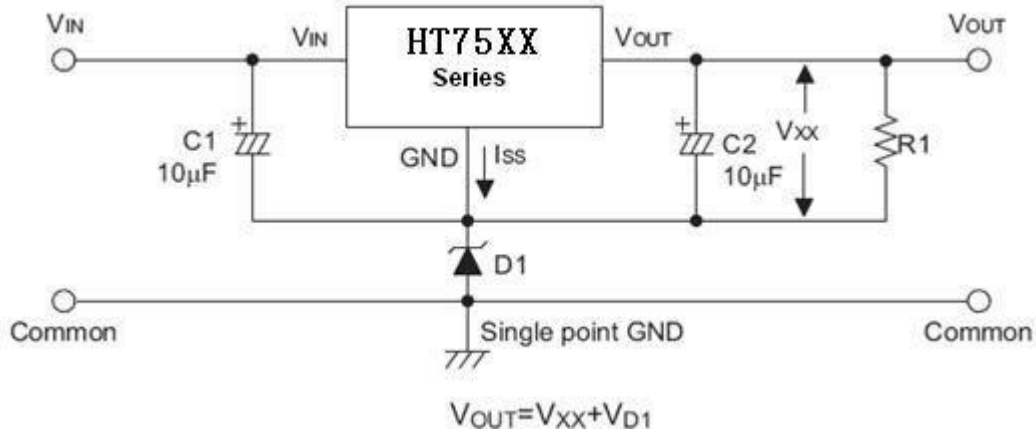

Constant Current Regulator

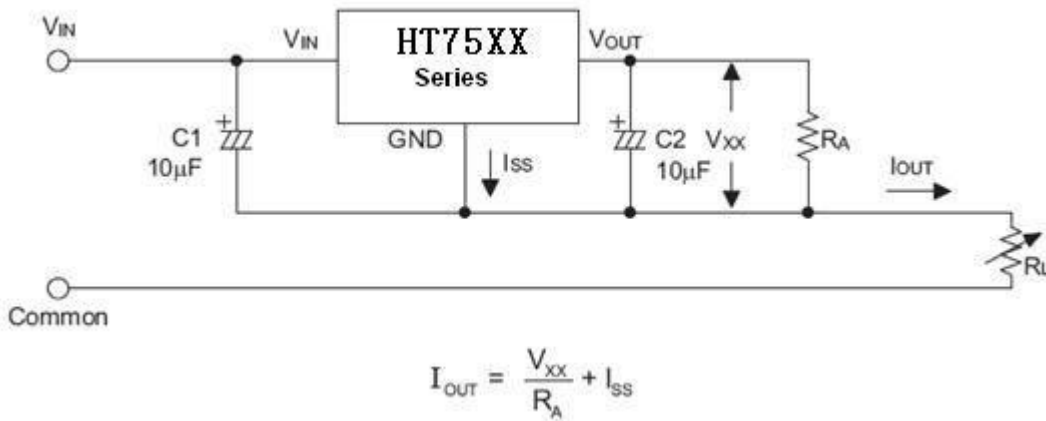

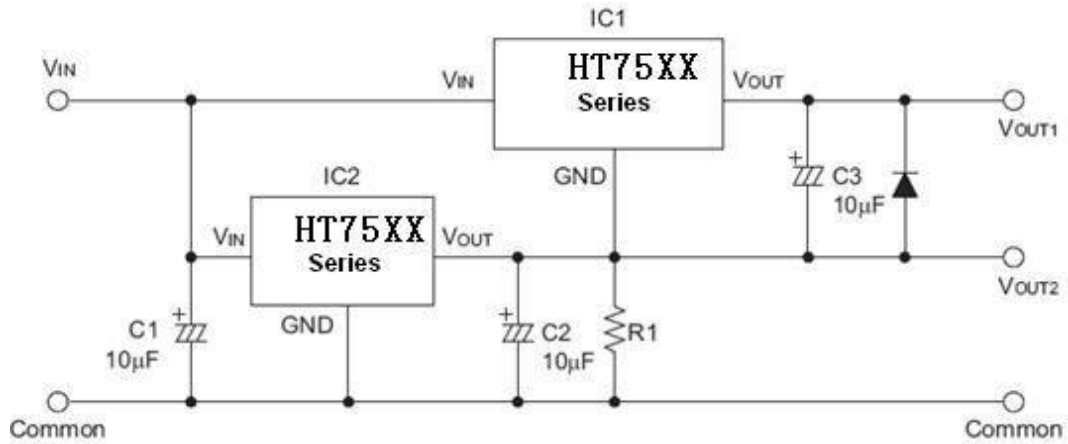
Dual Supply**Package Information**
3-pin TO92 Outline Dimensions

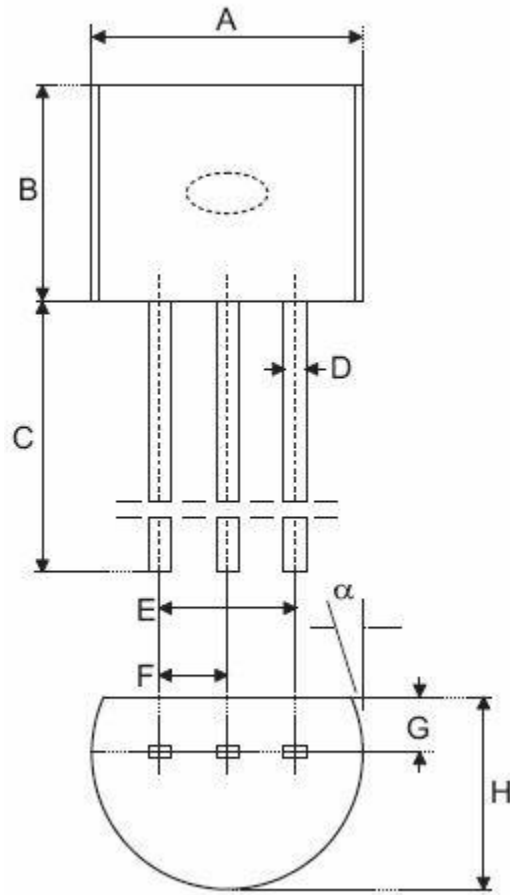

Symbol	Dimensions in mil		
	Min.	Nom.	Max.
A	170	—	200
B	170	—	200
C	500	—	—
D	11	—	20
E	90	—	110
F	45	—	55
G	45	—	65
H	130	—	160
I	8	—	18
α	4°	—	6°

3-pin SOT89 Outline Dimensions

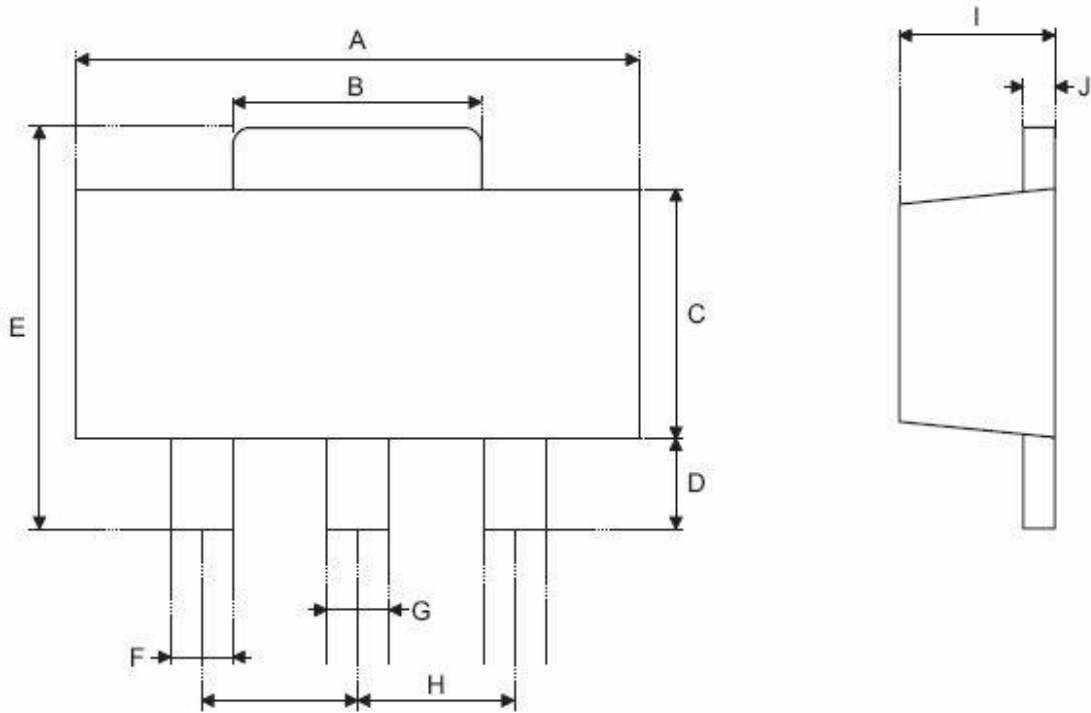

Symbol	Dimensions in mil		
	Min.	Nom.	Max.
A	173	—	181
B	59	—	72
C	90	—	102
D	35	—	47
E	155	—	167
F	14	—	19
G	17	—	22
H	—	59	—
I	55	—	63
J	14	—	17

5-pin SOT23-5 Outline Dimensions

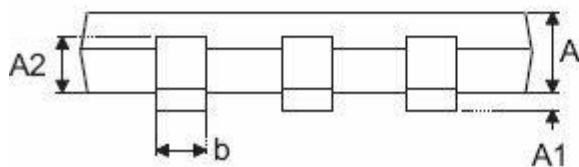
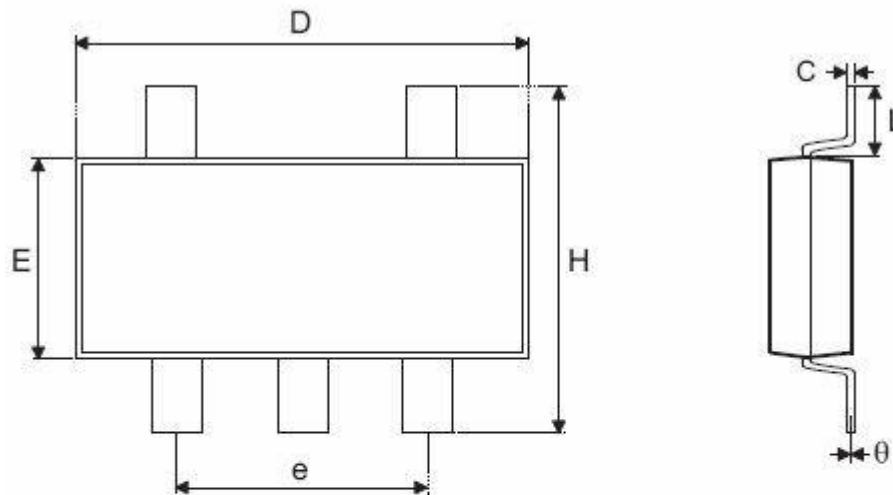

Symbol	Dimensions in mm		
	Min.	Nom.	Max.
A	1.00	—	1.30
A1	—	—	0.10
A2	0.70	—	0.90
b	0.35	—	0.50
C	0.10	—	0.25
D	2.70	—	3.10
E	1.40	—	1.80
e	—	1.90	—
H	2.60	—	3.00
L	0.37	—	—
θ	1°	—	9°

Product Tape and Reel Specifications

3-pin TO92 Reel Dimensions (Unit: mm)

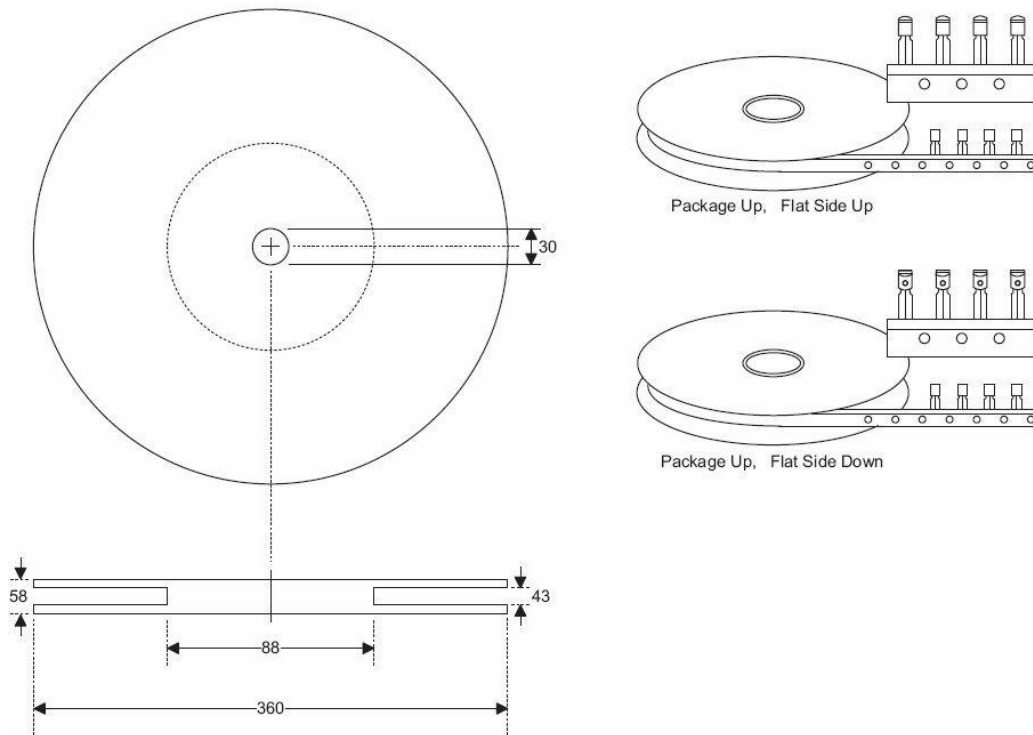

Reel Dimensions

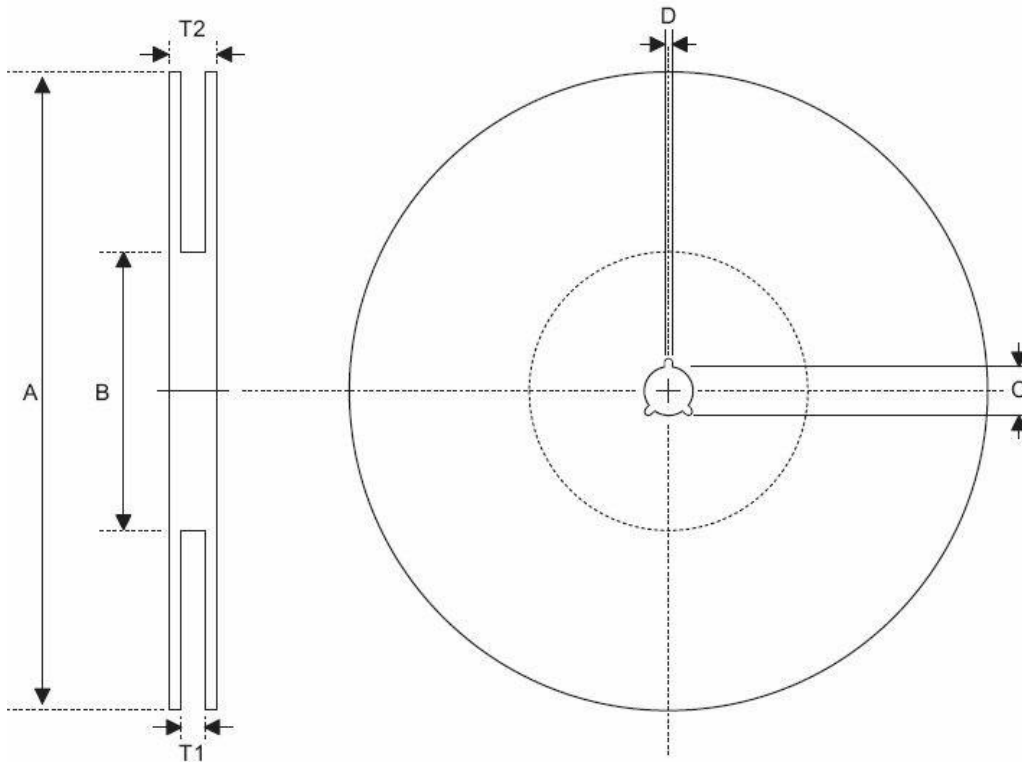

SOT89

Symbol	Description	Dimensions in mm
A	Reel Outer Diameter	180.0±1.0
B	Reel Inner Diameter	62.0±1.5
C	Spindle Hole Diameter	12.75 ^{+0.15/-0.00}
D	Key Slit Width	1.90±0.15
T1	Space Between Flange	12.4 ^{+0.2/-0.00}
T2	Reel Thickness	17.0 ^{+0.0/-0.4}

SOT23-5

Symbol	Description	Dimensions in mm
A	Reel Outer Diameter	178.0±1.0
B	Reel Inner Diameter	62.0±1.0
C	Spindle Hole Diameter	13.0±0.2
D	Key Slit Width	2.50±0.25
T1	Space Between Flange	8.4 ^{+1.5/-0.0}
T2	Reel Thickness	11.4 ^{+1.5/-0.0}

Carrier Tape Dimensions

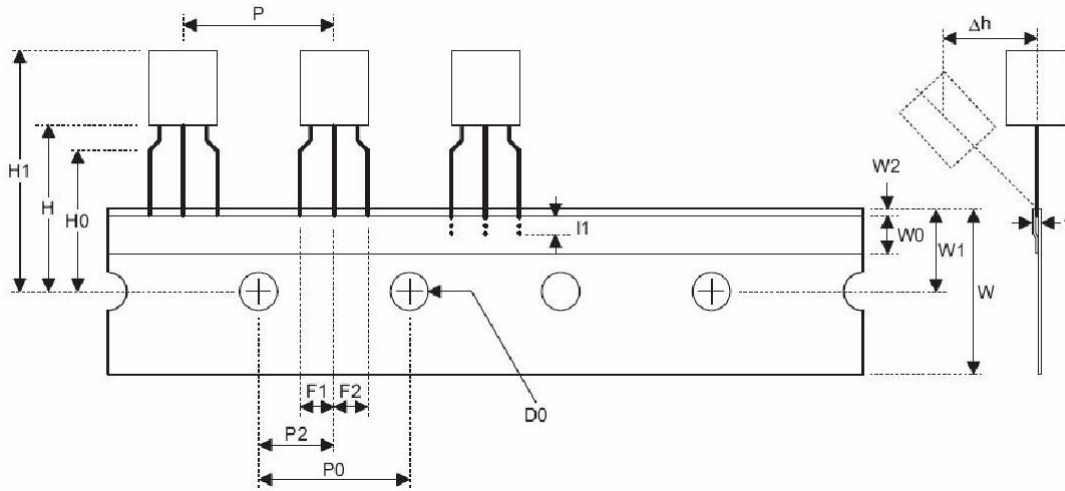

TO92

Symbol	Description	Dimensions in mm
I1	Taped Lead Length	(2.5)
P	Component Pitch	12.7±1.0
P ₀	Perforation Pitch	12.7±0.3
P ₂	Component to Perforation (Length Direction)	6.35±0.40
F ₁	Lead Spread	2.5 ^{+0.4/-0.1}
F ₂	Lead Spread	2.5 ^{+0.4/-0.1}
Δh	Component Alignment	0.0±0.1
W	Carrier Tape Width	18.0 ^{+1.0/-0.5}
W ₀	Hold-down Tape Width	6.0±0.5
W ₁	Perforation Position	9.0±0.5
W ₂	Hold-down Tape Position	(0.5)
H ₀	Lead Clinch Height	16.0±0.5
H ₁	Component Height	Less than 24.7
D ₀	Perforation Diameter	4.0±0.2
t	Taped Lead Thickness	0.7±0.2
H	Component Base Height	19.0±0.5

Note: Thickness less than 0.38_0.05mm~0.5mm

P₀ Accumulated pitch tolerance: _1mm/20pitches.

() Bracketed figures are for consultation only

Carrier Tape Dimensions

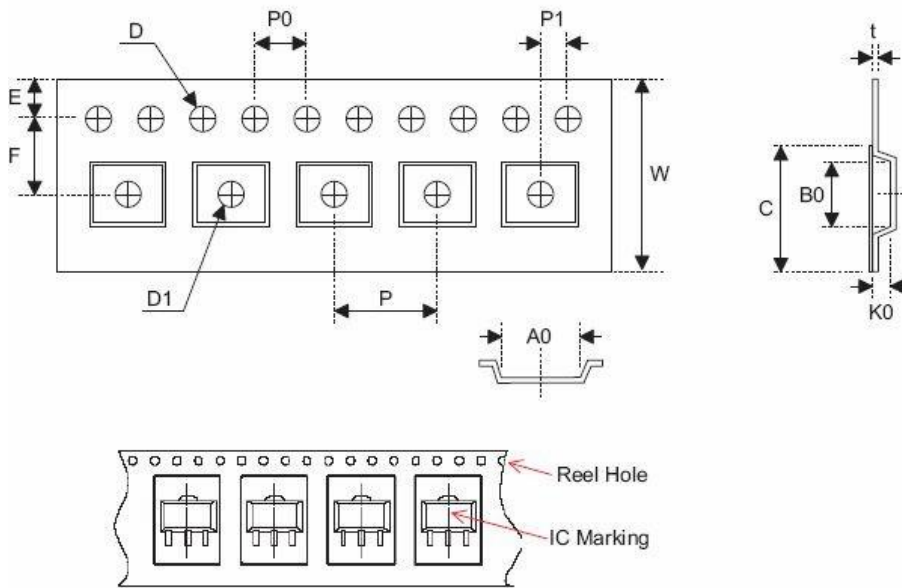

SOT89

Symbol	Description	Dimensions in mm
W	Carrier Tape Width	12.0 ^{+0.3/-0.1}
P	Cavity Pitch	8.0±0.1
E	Perforation Position	1.75±0.10
F	Cavity to Perforation (Width Direction)	5.50±0.05
D	Perforation Diameter	1.5 ^{+0.1/-0.0}
D1	Cavity Hole Diameter	1.5 ^{+0.1/-0.0}
P0	Perforation Pitch	4.0±0.1
P1	Cavity to Perforation (Length Direction)	2.0±0.1
A0	Cavity Length	4.8±0.1
B0	Cavity Width	4.5±0.1
K0	Cavity Depth	1.8±0.1
t	Carrier Tape Thickness	0.300±0.013
C	Cover Tape Width	9.3±0.1

SOT23-5

Symbol	Description	Dimensions in mm
W	Carrier Tape Width	8.0±0.3
P	Cavity Pitch	4.0±0.1
E	Perforation Position	1.75±0.10
F	Cavity to Perforation (Width Direction)	3.50±0.05
D	Perforation Diameter	1.5 ^{+0.1/-0.0}
D1	Cavity Hole Diameter	1.5 ^{+0.1/-0.0}
P0	Perforation Pitch	4.0±0.1
P1	Cavity to Perforation (Length Direction)	2.00±0.05
A0	Cavity Length	3.15±0.10
B0	Cavity Width	3.2±0.1
K0	Cavity Depth	1.4±0.1
t	Carrier Tape Thickness	0.20±0.03
C	Cover Tape Width	5.3±0.1