



---

# SK3400R

LTE-Band40, RF SAW Filter  
Revision 1 : December 2015

**MSL 3 Device**



- Electrical Characteristics
  - Package Dimensions
  - Testing Environment
  - Frequency Characteristics
-

## □ Electrical Characteristics

### Maximum Ratings

Parameters Description	Unit	Minimum	Typical	Maximum
Operating Temperature Range	°C	-30	-	+85
Storage Temperature Range	°C	-40	-	+85
Maximum DC Voltage	V	-	-	0
Maximum Input Power	dBm	-	-	10
Source Impedance (single ended) <sup>(1)</sup>	Ω	-	50	-
Load Impedance (single ended) <sup>(1)</sup>	Ω	-	50	-
Package type & size	C12			
Length x Width	mm <sup>2</sup>	-	1.1 x 0.9	-
Height	mm	-	-	0.65

### Electrical Specification

Parameters Description	Unit	Minimum	Typical	Maximum
Center Frequency (Fo)	MHz	-	2350.0	-
Max.Insertion Loss within 2300.0~2400.0 MHz	dB	-	1.9	2.8
Amplitude Ripple within 2300.0~2400.0 MHz	dB <sub>p-p</sub>	-	1.2	2.3
<b>Attenuation:</b>				
10.0 ~ 1574.0 MHz	dB	20	29	-
1574.0 ~ 1577.0 MHz	dB	20	29	-
1577.0 ~ 1680.0 MHz	dB	20	27	-
1845.0 ~ 1880.0 MHz	dB	18	25	-
2110.0 ~ 2170.0 MHz	dB	18	25	-
2240.0 ~ 2285.0 MHz	dB	1.5	7	-
2415.0 ~ 2420.0 MHz	dB	1.5	5	-
2420.0 ~ 2460.0 MHz	dB	3	6	-
2460.0 ~ 2485.0 MHz	dB	30	43	-
2485.0 ~ 2500.0 MHz	dB	30	48	-
2500.0 ~ 3000.0 MHz	dB	20	26	-
4600.0 ~ 4800.0 MHz	dB	20	25	-
4800.0 ~ 6000.0 MHz	dB	18	21	-
VSWR within 2300.0~2400.0 MHz	-	-	1.5	2.0

**Notes :** (1) With Matching Network .

## Package Dimensions

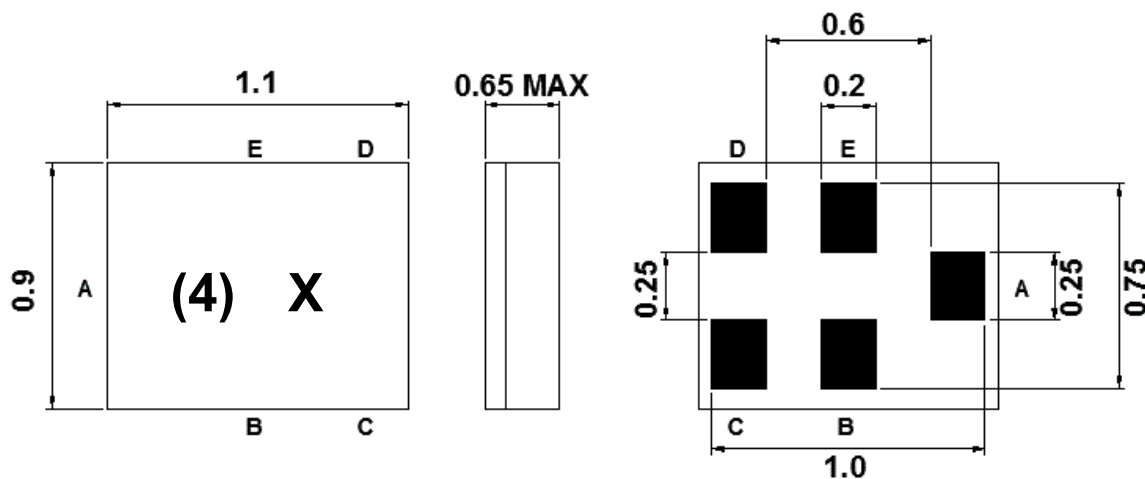

Marking Descriptions	
(4)	Series Number
X	Date Code(Year+Month)

Pin Description	
B, C, E	Ground
A	Input
D	Output

## Testing Environment

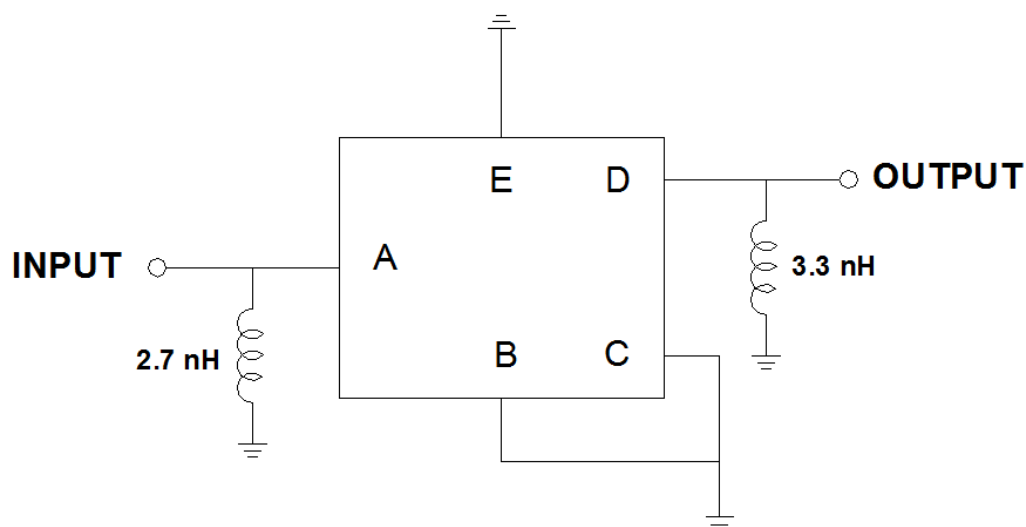

## □ Frequency Characteristics

Frequency Response

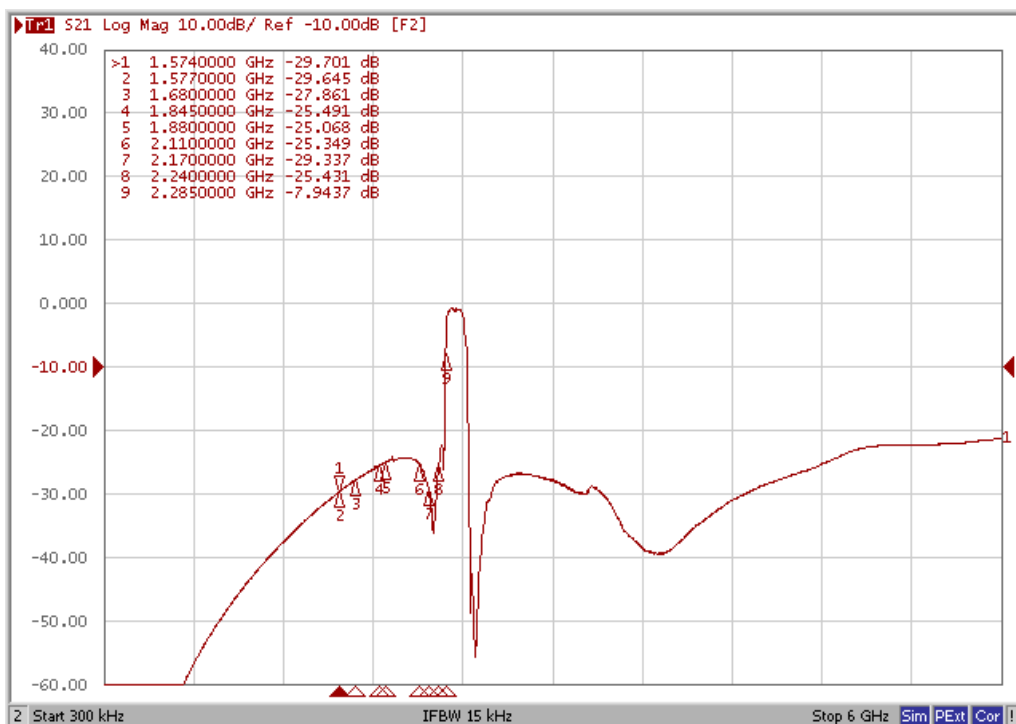
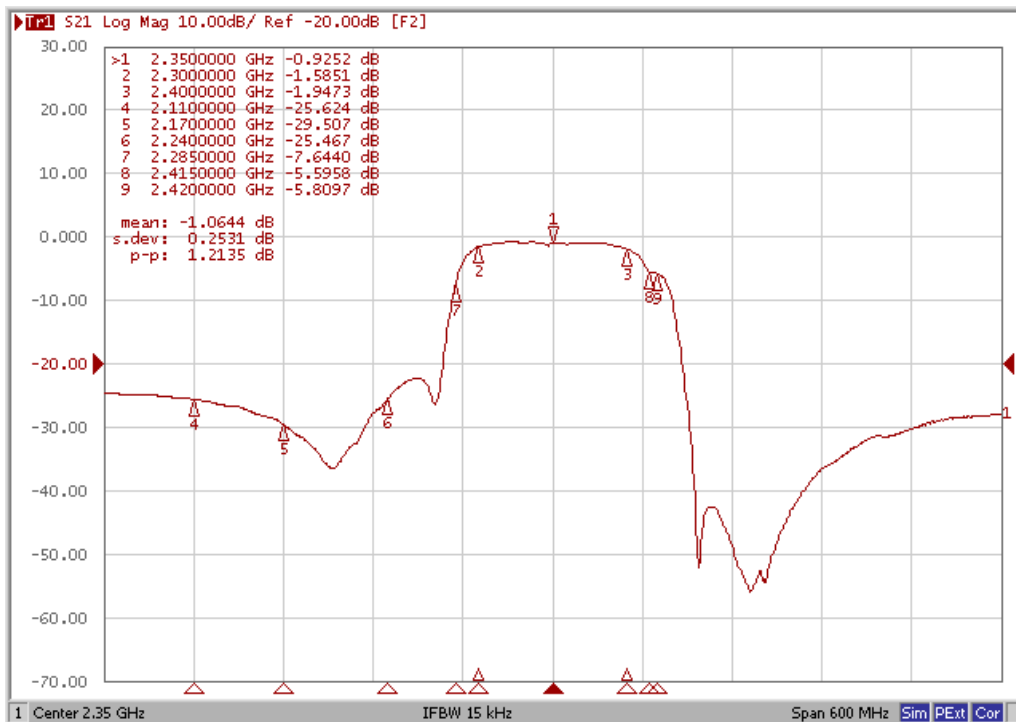

### VSWR

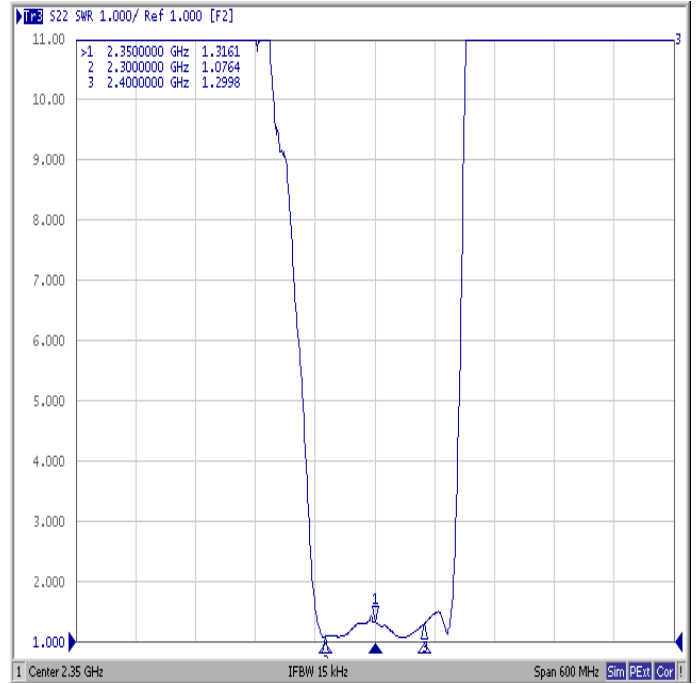
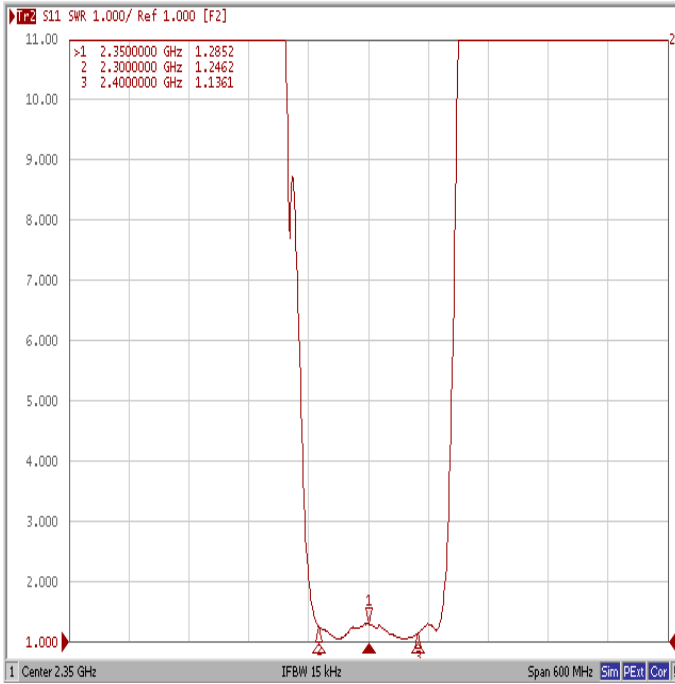

### Smith Chart

