

DIO235X

12 μ V V_{OS} , 1.2MHz, RRIO CMOS High-Precision Amplifier

Features

- Rail-to-Rail Input and Output
- Low offset (V_{OS}): 12 μ V typ.
- Input offset drift: 0.01 μ V/ $^{\circ}$ C
- Unity Gain Stable
- Gain Bandwidth Product: 1.2MHz
- Very low input bias currents: 20pA
- Wide supply range: 2.5V to 5.5V
- Single Supply Operation
- Low power: 0.73mA per channel
- Small size packaging best for portable applications:
DIO2351: SOT23-5, SOIC-8
DIO2352: SOIC-8, MSOP-8 and TSSOP-8
DIO2354: TSSOP-14

Applications

- Temperature measurement
- Pressure sensor
- Precision current sensing
- Strain Gage Amplifier
- Medical instrument
- Thermocouple amplifier
- Handheld Test Equipment

Descriptions

The DIO235X is an ultra-low offset voltage rail-to-rail input and output voltage feedback amplifier. They have a wide input common-mode voltage range and output voltage swing, and take the operating supply voltage is from 2.5 to 5.5V. They provide 1.2MHz bandwidth.

The DIO235X features an offset voltage of only 12 μ V and drift of 0.01 μ V/ $^{\circ}$ C, which makes the product perfect in applications of intolerant errors. Temperature/position/pressure sensors and medical equipment can benefit greatly from nearly zero drift over their operating temperature range.

Typical Application

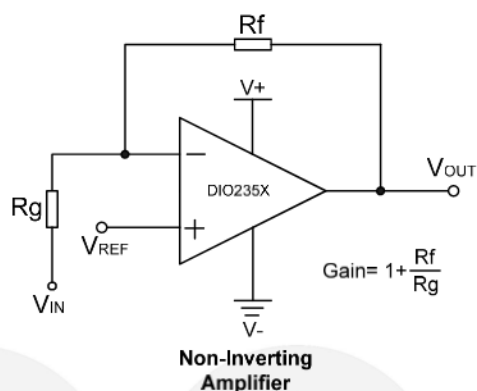

Ordering Information

Order Part Number	Top Marking		T_A	Package	
DIO2351ST5	YWXM	Green/RoHS	-40 to +125 $^{\circ}$ C	SOT23-5	Tape & Reel, 3000
DIO2351SO8	DIO2351	Green/RoHS	-40 to +125 $^{\circ}$ C	SOIC-8	Tape & Reel, 2500
DIO2352MP8	DIO2352	Green/RoHS	-40 to +125 $^{\circ}$ C	MSOP-8	Tape & Reel, 3000
DIO2352SO8	DIO2352	Green/RoHS	-40 to +125 $^{\circ}$ C	SOIC-8	Tape & Reel, 2500
DIO2352TP8	DIO2352	Green/RoHS	-40 to +125 $^{\circ}$ C	TSSOP-8	Tape & Reel, 3000
DIO2354CT14	DIO2354	Green/RoHS	-40 to +125 $^{\circ}$ C	TSSOP-14	Tape & Reel, 2500

Pin Assignments

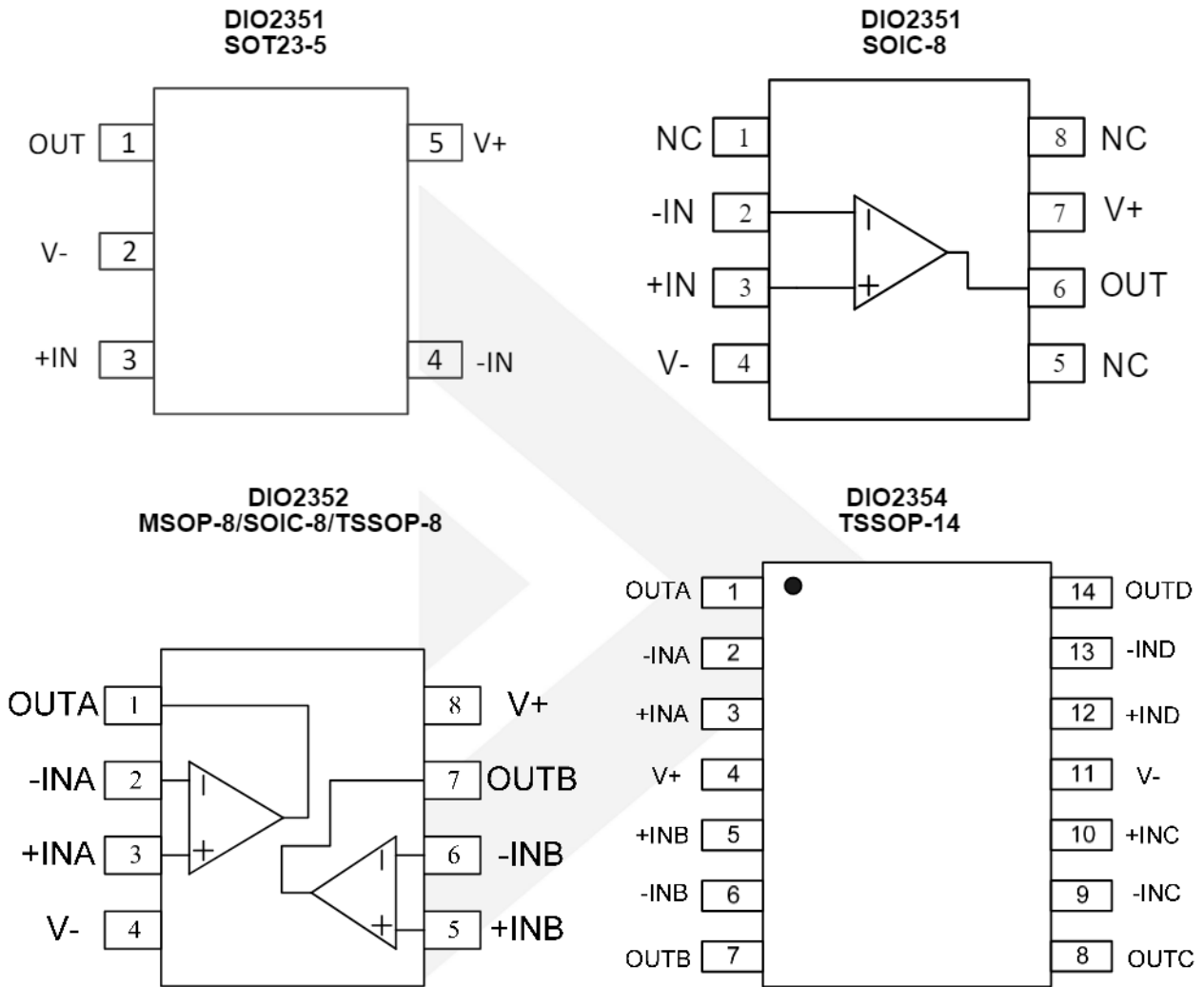

Figure 1 Pin Assignment

Pin Description

Pin name	Description
V+	Positive supply
V-	Negative supply
+IN(A/B/C/D)	Positive Input
-IN(A/B/C/D)	Negative Input
OUT(A/B/C/D)	Output

Absolute Maximum Ratings

Stresses beyond those listed under "Absolute Maximum Rating" may cause permanent damage to the device. These are stress ratings only and functional operation of the device at these or any other condition beyond those indicated in the operational sections of the specifications is not implied. Exposure to absolute maximum rating conditions for extended periods may affect device reliability.

Parameter		Rating	Unit
Supply Voltage		7.5	V
Input Voltage		(-Vs)-0.3 to (+Vs) +0.3V	V
TSSOP-14 θ_{JA}		110	$^{\circ}$ C/W
Storage Temperature Range		-65 to 150	$^{\circ}$ C
Junction Temperature		150	$^{\circ}$ C
Lead Temperature Range		260	$^{\circ}$ C
ESD	HBM, JEDEC: JESD22-A114	7	kV

Recommended Operating Conditions

The Recommended Operating Conditions table defines the conditions for actual device operation to ensure optimal performance to the datasheet specifications. DIOO does not recommend exceeding them or designing to Absolute Maximum Ratings.

Parameter		Rating	Unit
Supply Voltage		2.5 to 5.5	V
Input Voltage		0 to 5	V
Operating Temperature Range		-40 to 125	$^{\circ}$ C



Electrical Characteristics

Typical value: $V_+ = 5V$, $R_L = 100k\Omega$ to $V_+/2$, $T_A = 25^\circ C$, unless otherwise specified.

Symbol	Parameter	Conditions	Min.	Typ.	Max.	Unit
INPUT CHARACTERISTICS						
V_{OS}	Input Offset Voltage		-30	12	30	μV
I_B	Input Bias Current			20		pA
CMRR	Common Mode Rejection Ratio	$V_{CM} = -0.1$ to $(V_+) + 0.1$		80		dB
A_{OL}	Open Loop Voltage Gain	$R_L = 10k\Omega$, $V_O = 0.1$ to $(V_+) - 0.1$		150		dB
$\Delta V_{OS}/\Delta T$	Input Offset Voltage Drift	$-40^\circ C \leq T_A \leq 125^\circ C$		0.01		$\mu V/^\circ C$
OUTPUT CHARACTERISTICS						
V_{OH}	Output Voltage High	$R_L = 100k\Omega$, $-40^\circ C \leq T_A \leq 125^\circ C$		4.998		V
		$R_L = 10k\Omega$, $-40^\circ C \leq T_A \leq 125^\circ C$		4.99		
V_{OL}	Output Voltage Low	$R_L = 100k\Omega$, $-40^\circ C \leq T_A \leq 125^\circ C$		1.2		mV
		$R_L = 10k\Omega$, $-40^\circ C \leq T_A \leq 125^\circ C$		7.3		
I_O	Output Current	Source Current		55		mA
		Sink Current		55		
POWER SUPPLY						
PSRR	Power Supply Rejection Ration	$V_S = 2.7V$ to $5.5V$		105		dB
I_S	Supply Current per Channel/Amp	$-40^\circ C \leq T_A \leq 125^\circ C$		730		μA
DYNAMIC PERFORMANCE						
GBP	Gain Bandwidth Product			1.2		MHz
SR	Slew Rate	$G=1$, 2V Output Step		1		V/ μs
	Overload Recovery Time			8		μs
t_S	Setting Time	$G=1$, 2V Output Step		2		μs
NOISE PERFORMANCE						
THD	Total Harmonic Distortion	$f=1kHz$, 2V Output Step, $R_L=10k\Omega$,		0.0014		%
e_n	Voltage Noise Density	$f=1kHz$		40		nV/ \sqrt{Hz}

Specifications subject to change without notice.

Typical Performance Characteristics

All typical value are at $V_+=5V$, $R_L=200k\Omega$ to $V_+/2$, $T_A = 25^\circ C$, unless otherwise specified.

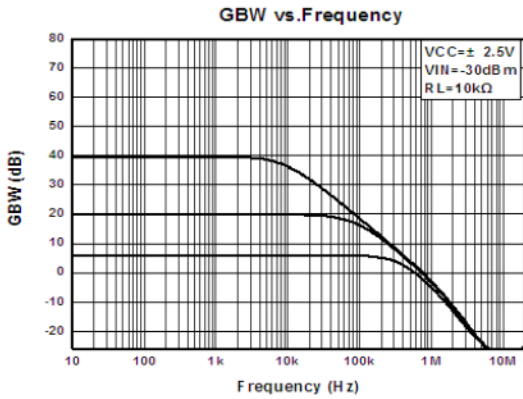

GBW vs. Frequency
Figure 2

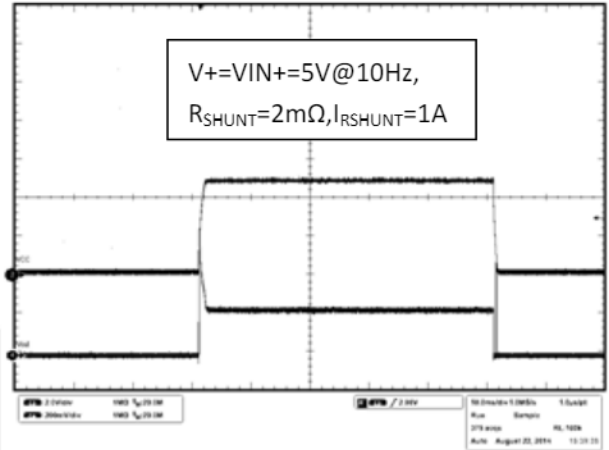

Start Off Recovery
Figure 3

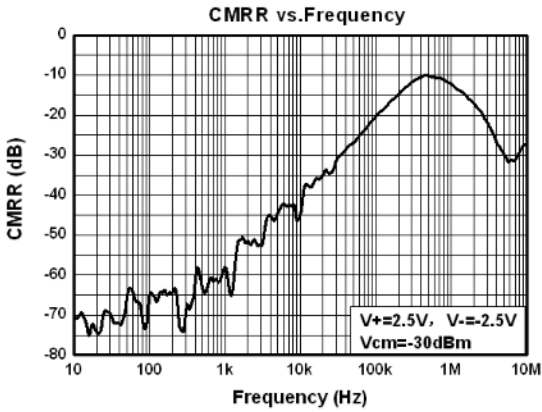

CMRR vs. frequency
Figure 4

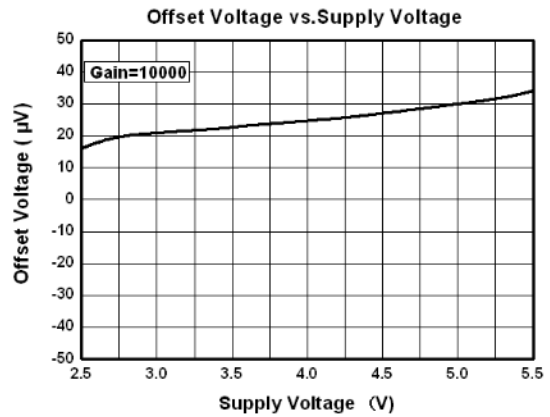

Offset Voltage vs. Supply Voltage
Figure 5

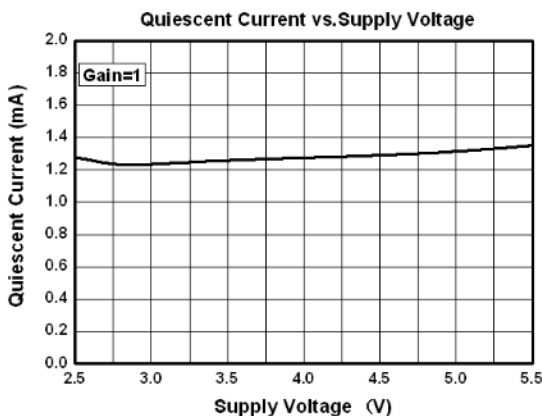

Offset Voltage vs. Supply Voltage
Figure 6

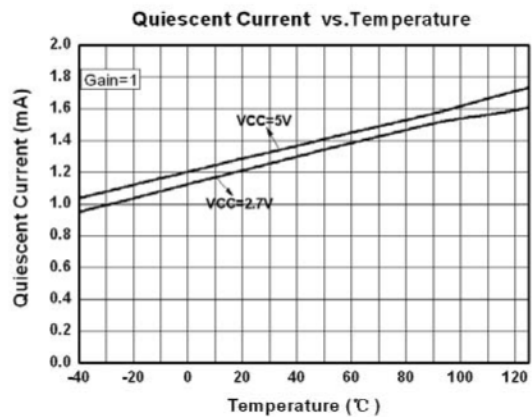

Quiescent Current vs. Temperature
Figure 7

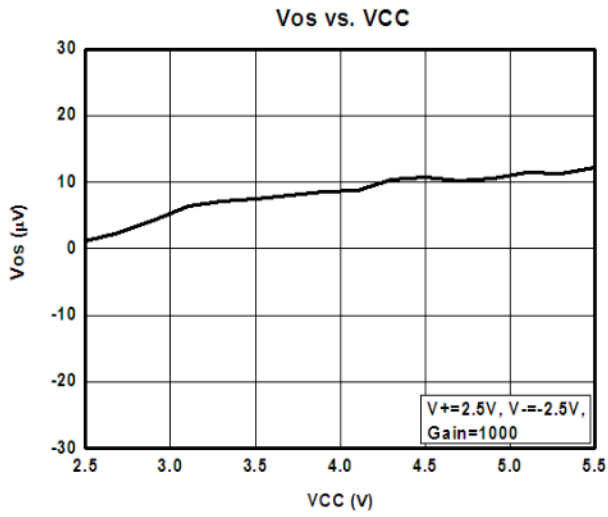

V_{OS} vs. VCC

Figure 9

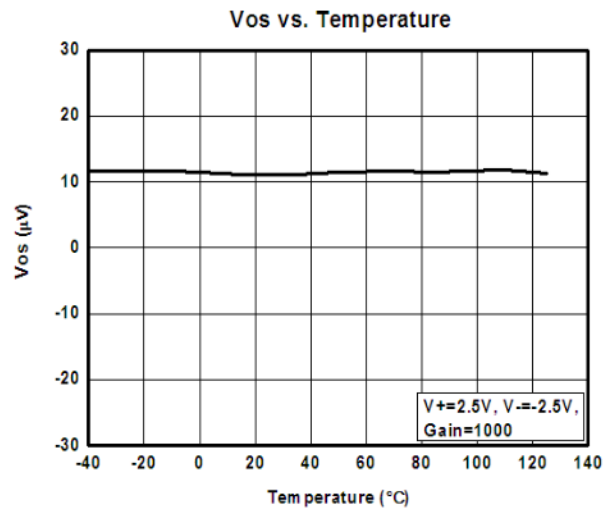

V_{OS} vs. Temperature

Figure 10



CONTACT US

Dioo is a professional design and sales corporation for high-quality and performance analog semiconductors. The company focuses on industry markets, such as, cell phone, handheld products, laptop, and medical equipment and so on. Dioo's product families include analog signal processing and amplifying, LED drivers and charger IC. Go to <http://www.dioo.com> for a complete list of Dioo product families.

For additional product information, or full datasheet, please contact with our Sales Department or Representatives.

