

## 100V N-Channel Enhancement Mode MOSFET

### Description

The NP36N10 uses advanced trench technology to provide excellent  $R_{DS(ON)}$  and low gate charge. It can be used in a wide variety of applications.

### General Features

- ◆  $V_{DS} = 100V$   $I_D = 36A$   
 $R_{DS(ON)}(Typ.) = 32m\Omega$  @  $V_{GS} = 10V$   
 $R_{DS(ON)}(Typ.) = 38m\Omega$  @  $V_{GS} = 4.5V$
- ◆ High density cell design for ultra low  $R_{dson}$
- ◆ Fully characterized avalanche voltage and current
- ◆ Good stability and uniformity with high  $E_{AS}$
- ◆ Excellent package for good heat dissipation
- ◆ Special process technology for high ESD capability

### Application

- ◆ Automotive applications
- ◆ Hard switched and high frequency circuits
- ◆ Uninterruptible power supply

### Package

- ◆ TO-252-2L

*100% UIS TESTED!*

*100%  $\Delta V_{ds}$  TESTED!*

### Schematic diagram

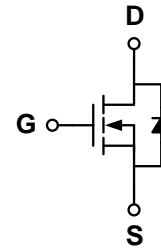

### Marking and pin assignment

**TO-252-2L**

(Top View)

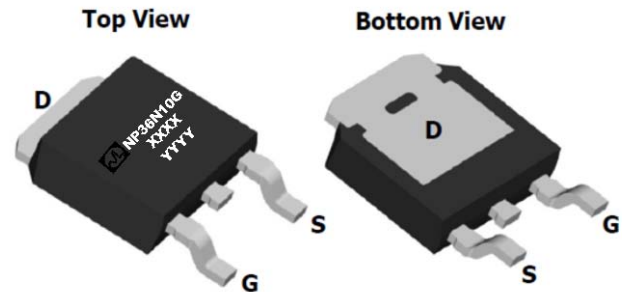

### Ordering Information

Part Number	Storage Temperature	Package	Devices Per Reel
NP36N10G	-55°C to +150°C	TO-252-2L	2500

### Absolute Maximum Ratings (TA=25°C unless otherwise noted)

parameter	symbol	limit	unit
Drain-source voltage	$V_{DS}$	100	V
Gate-source voltage	$V_{GS}$	±20	V
Continuous Drain Current	$I_D$	TC=25°C	36
		TC=100°C	26
Pulsed Drain Current	$I_{DP}$	144	A
Avalanche energy( L=0.5mH)	$E_{AS}$	55	mJ
Maximum power dissipation	$P_D$	50	W
Operating junction Temperature range	$T_j$	-55—150	°C

**Electrical Characteristics** (TA=25°C unless otherwise noted)

Parameter	Symbol	Condition	Min	Typ	Max	Unit	
<b>Static Characteristics</b>							
Drain-source breakdown voltage	$BV_{DSS}$	$V_{GS}=0V, I_D=250\mu A$	100	-	-	V	
Zero gate voltage drain current	$I_{DSS}$	$V_{DS}=100V, V_{GS}=0V$	$T_J=25^\circ C$	-	-	1	$\mu A$
			$T_J=85^\circ C$	-	-	30	
Gate Leakage Current	$I_{GSS}$	$V_{DS}=0V, V_{GS}=\pm 20V$	-	-	$\pm 100$	nA	
Gate threshold voltage	$V_{GS(th)}$	$V_{DS}=V_{GS}, I_D=250\mu A$	1	1.6	2.5	V	
Drain-source on-state resistance <sup>1</sup>	$R_{DS(ON)}$	$V_{GS}=10V, I_D=30A$	-	32	42	m $\Omega$	
		$V_{GS}=4.5V, I_D=10A$	-	38	48		
On Status Drain Current	$I_{D(ON)}$	$V_{DS}=100V, V_{GS}=10V$	36	-	-	A	
<b>Diode Characteristics</b>							
Diode Continuous Forward Current	$I_S$		-	-	36	A	
Reverse Recovery Time	$t_{rr}$	$I_F=10A,$	-	32	-	ns	
Reverse Recovery Charge	$Q_{rr}$	$di/dt=500A/us$	-	200	-	nC	
<b>Dynamic Characteristics<sup>2</sup></b>							
Input capacitance	$C_{ISS}$	$V_{GS}=0V, V_{DS}=50V$ $f=1.0MHz$	-	1630	-	pF	
Output capacitance	$C_{OSS}$		-	100	-		
Reverse transfer capacitance	$C_{RSS}$		-	50	-		
Turn-on delay time	$t_{D(ON)}$	$V_{GS}=10V, V_{DS}=50V, R_L=5\Omega,$ $R_{GEN}=3\Omega$	-	7	-	ns	
Turn-on Rise time	$t_r$		-	7	-		
Turn-off delay time	$t_{D(OFF)}$		-	29	-		
Turn-off Fall time	$t_f$		-	7	-		
Total gate charge	$Q_g$	$V_{GS}=10V, I_D=10A$ $V_{DS}=50V$	-	34	-	nC	
Gate-source charge	$Q_{gs}$		-	6	-		
Gate-drain charge	$Q_{gd}$		-	9	-		
<b>Drain-Source Diode Characteristics</b>							
Diode forward voltage	$V_{SD}$	$I_{SD}=10A, V_{GS}=0V$	-	0.8	1.1	V	

Note: 1: Pulse test; pulse width  $\leq 300ns$ , duty cycle  $\leq 2\%$ .

2: Guaranteed by design, not subject to production testing.

## Typical Performance Characteristics

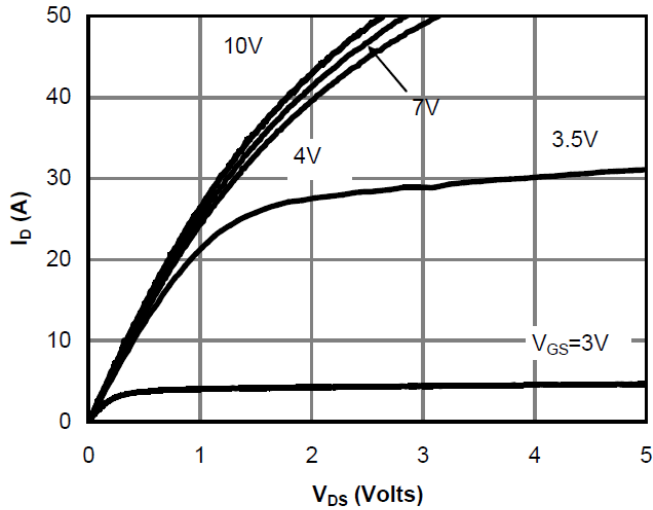

Fig 1: On-Region Characteristics

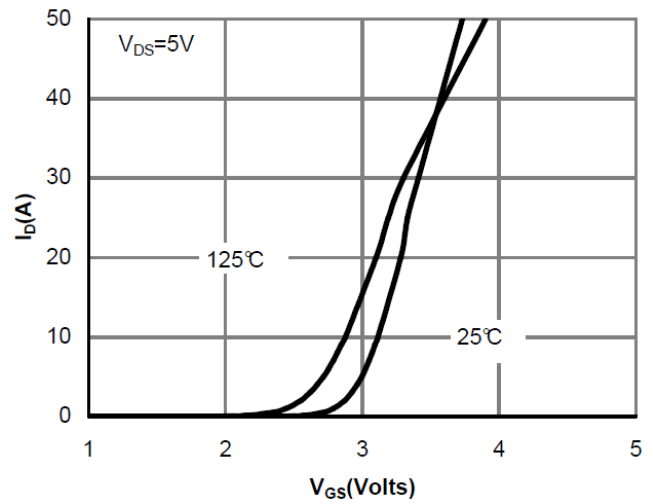

Figure 2: Transfer Characteristics

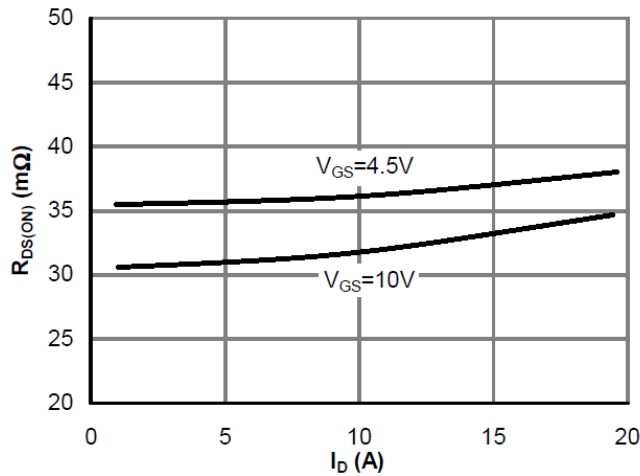

Figure 3: On-Resistance vs. Drain Current and Gate Voltage

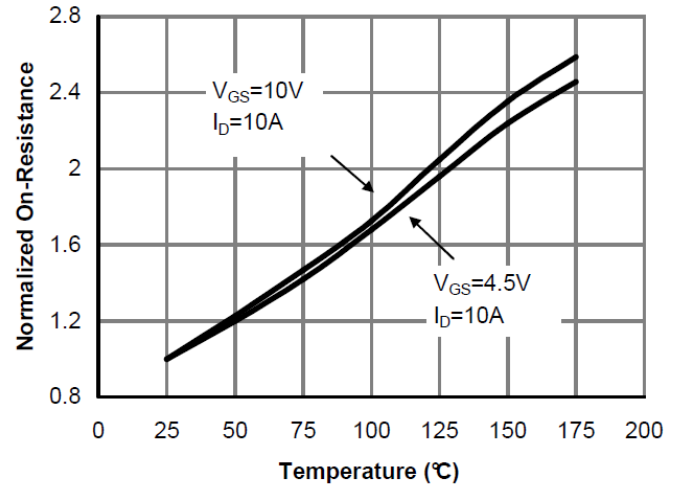

Figure 4: On-Resistance vs. Junction Temperature

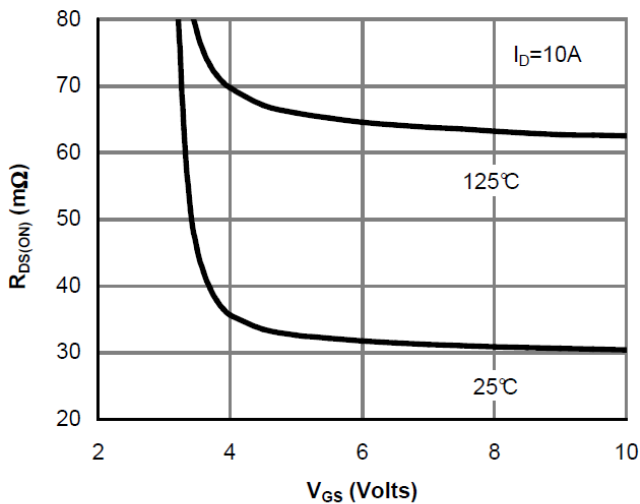

Figure 5: On-Resistance vs. Gate-Source Voltage

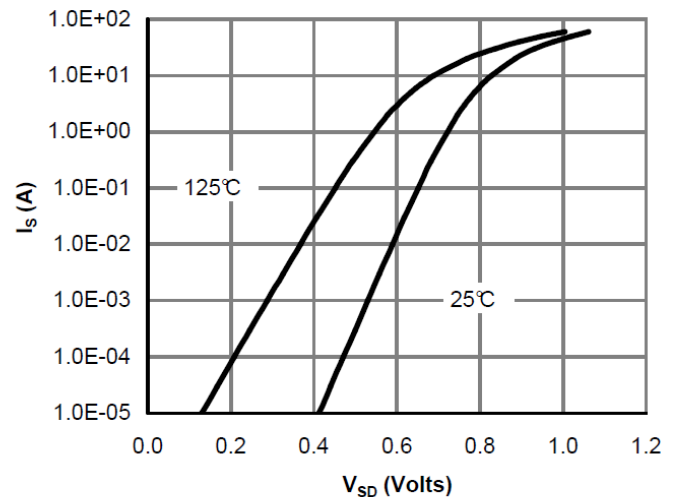

Figure 6: Body-Diode Characteristics

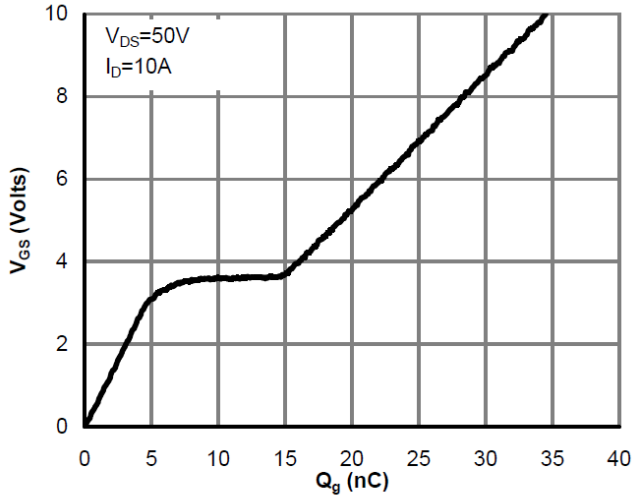
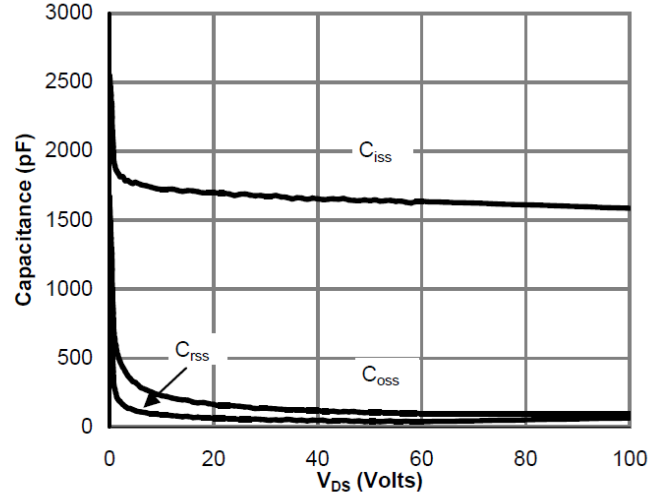
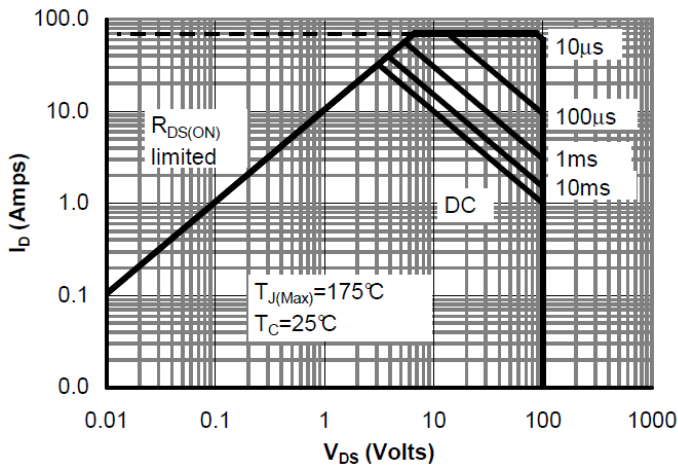
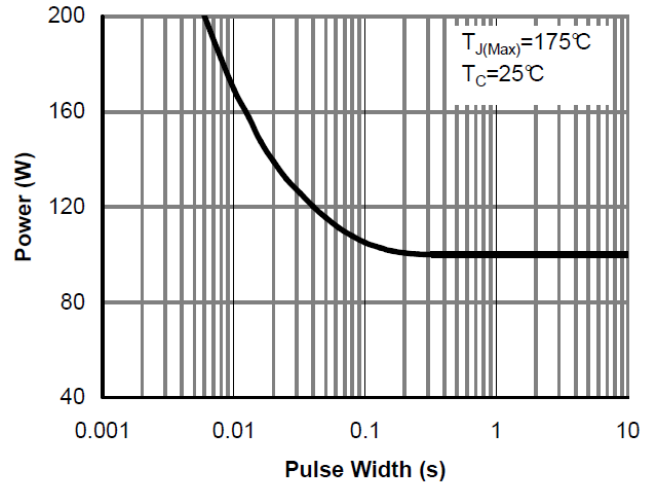
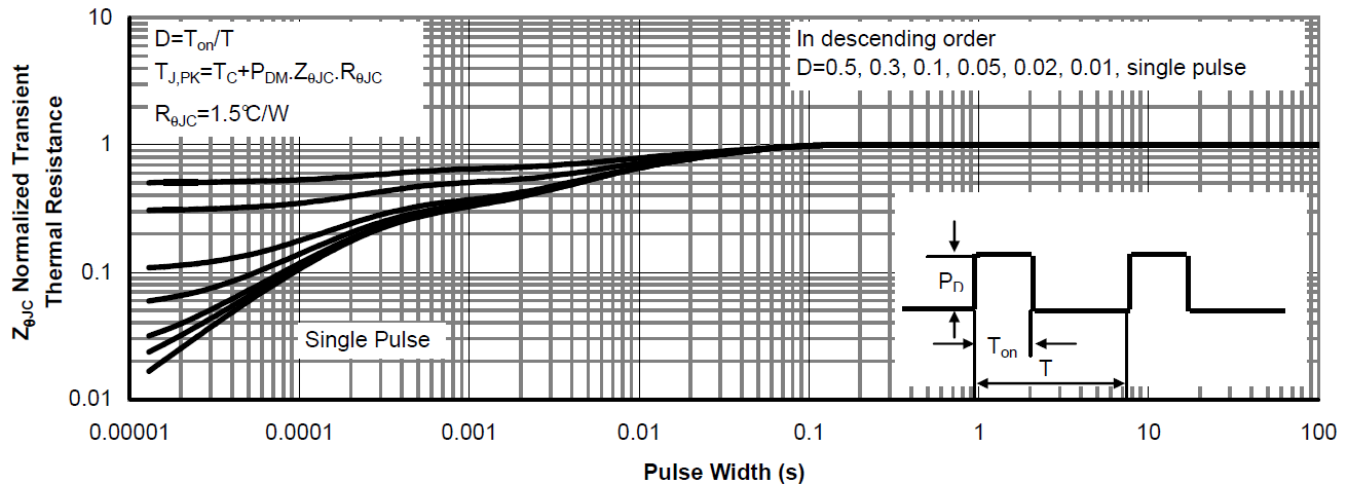

**Figure 7: Gate-Charge Characteristics**

**Figure 8: Capacitance Characteristics**

**Figure 9: Maximum Forward Biased Safe Operating Area**

**Figure 10: Single Pulse Power Rating Junction-to-Case**

**Figure 11: Normalized Maximum Transient Thermal Impedance**

Figure A: Gate Charge Test Circuit & Waveforms

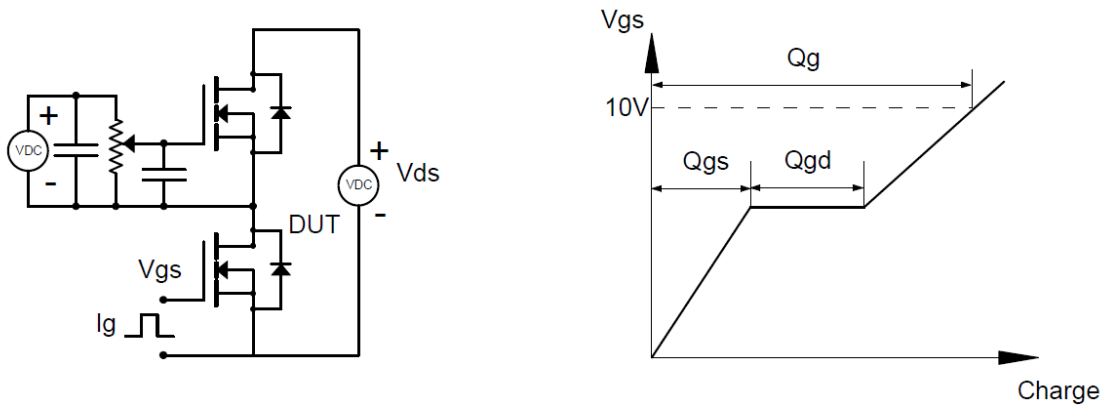

Figure B: Resistive Switching Test Circuit & Waveforms

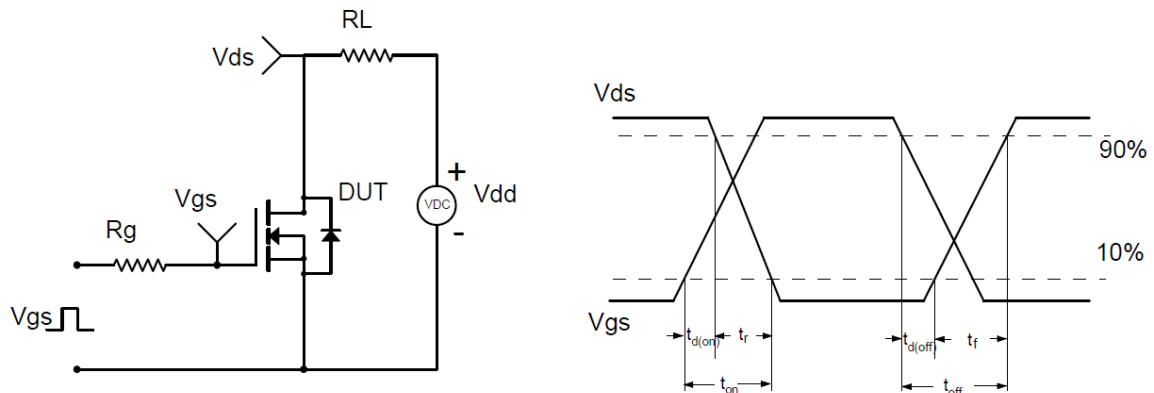

Figure C: Unclamped Inductive Switching (UIS) Test Circuit & Waveforms

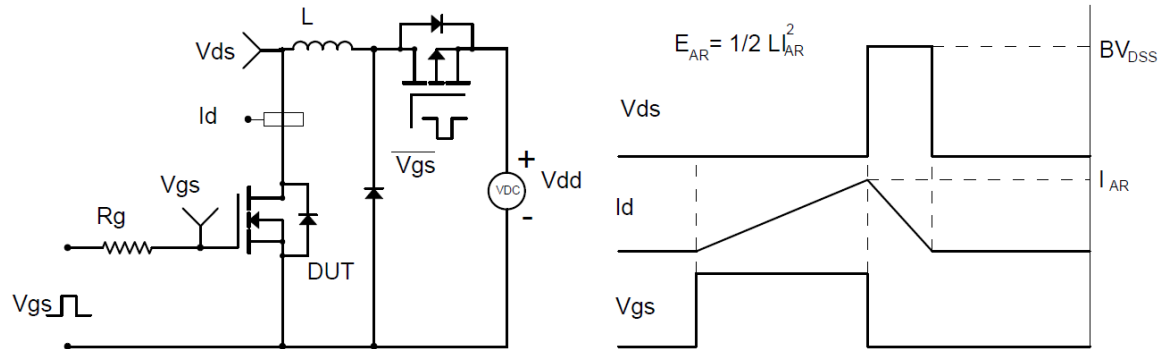
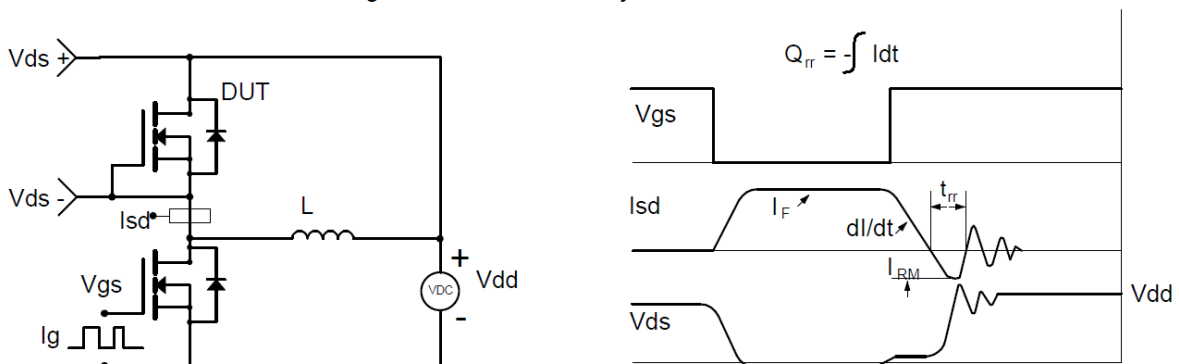
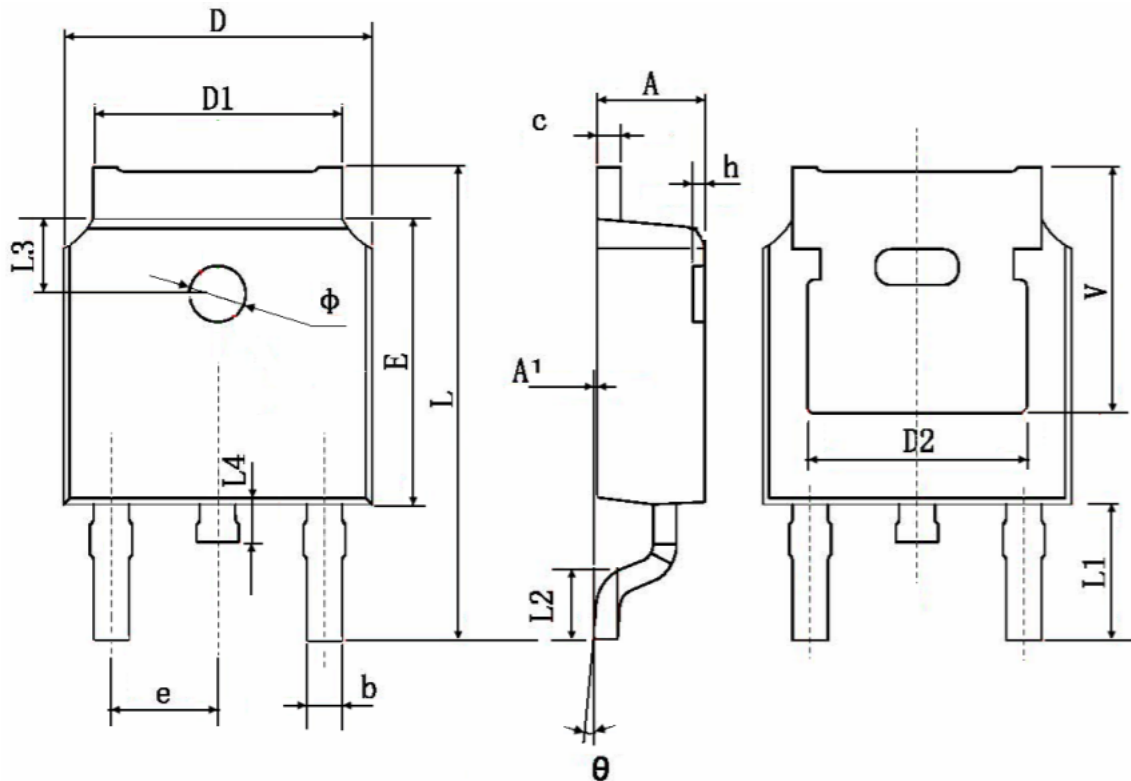

Figure D: Diode Recovery Test Circuit & Waveforms



## Package Information

- TO-252-2L



Symbol	Dimensions In Millimeters		Dimensions In Inches	
	Min.	Max.	Min.	Max.
A	2.200	2.400	0.087	0.094
A1	0.000	0.127	0.000	0.005
b	0.660	0.860	0.026	0.034
c	0.460	0.580	0.018	0.023
D	6.500	6.700	0.256	0.264
D1	5.100	5.460	0.201	0.215
D2	4.830 TYP.		0.190 TYP.	
E	6.000	6.200	0.236	0.244
e	2.186	2.386	0.086	0.094
L	9.800	10.400	0.386	0.409
L1	2.900 TYP.		0.114 TYP.	
L2	1.400	1.700	0.055	0.067
L3	1.600 TYP.		0.063 TYP.	
L4	0.600	1.000	0.024	0.039
φ	1.100	1.300	0.043	0.051
θ	0°	8°	0°	8°
h	0.000	0.300	0.000	0.012
V	5.350 TYP.		0.211 TYP.	