

REVISION RECORD			
REV.	CONTENT	MOD.	DATE
△	初版发行		

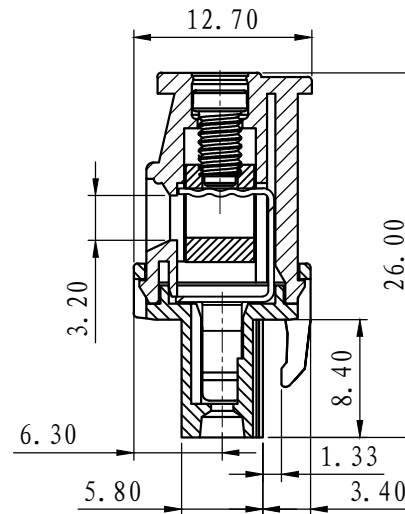
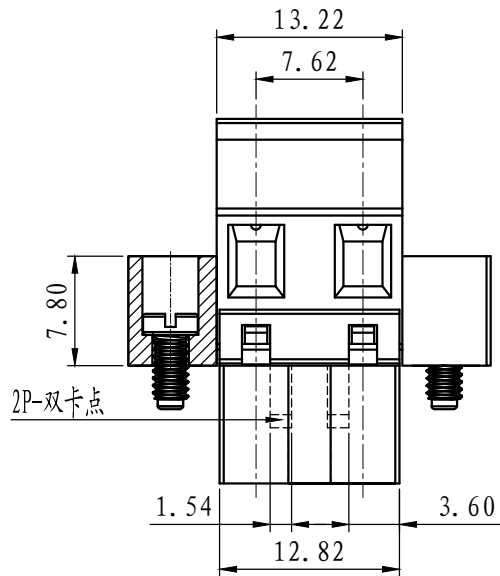
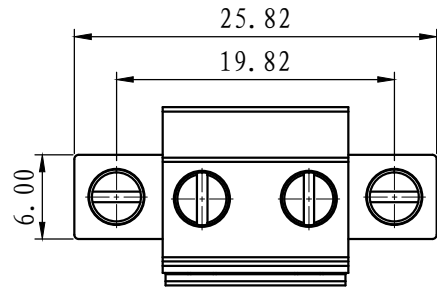

NOTES:

1. Voltage Rating: 400V, Current Rating: 20A
2. PITCH: 7.62mm
3. Insulation Withstands Voltage: AC2500V/min
4. Insulation Resistance: 500MΩ or more at DC500V
5. Using Temperature Range: -40° C - +105° C
6. Suitable Electric Wire: 30-12AWG
7. Screw Torque Value: 0.5Nm

技术要求:

1. 额定电压: 400V, 额定电流: 20A
2. 间距: 7.62mm
3. 耐电压值: AC 2500V/min
4. 绝缘阻抗: 500兆欧
5. 使用条件: -40° - +105°
6. 适用线规: 30-12AWG
7. 螺丝扭力: 0.5Nm

6	LC1-耳朵螺丝	SPOYA255301V	2	碳钢	三价铬钝化彩锌
5	LC1-5.08-螺丝	SPOVB305503V	P	碳钢	三价铬钝化彩锌
4	LC1-5.08-铜方块	F1A0BLC5083V	P	黄铜	镀镍
3	LC2-5.08-夹子	1006B0001AV	P	磷青铜	镀镍
2	LC2-7.62-盖子	1010C0YXXAV	1	PA66-V0	
1	LC2M-7.62-本体	1010M0YXXAV	1	PA66-V0	
NO.	NAME OF PART	NO. OF PART	Q' TY	MATERIAL	NOTES
DES.	ARKINE	DATE	11-04-01	UNITS	MM
CHK.		DATE		SIZE	A4
APP.		DATE		SCALE	1: 1
				DWG NO.	SP-2-1010004
				REV:	V0
				TITLE	LC2BM-7.62-2P-1Y-00A
					LC2BM-7.62-成品

	pitch dimension			Nominal dimension					— /
	over 0 to 6	over 6 to 10	over 10 to 24	over 0 to 30	over 30 to 60	over 60 to 100	over 100 to 150	over 150	
variable range	0 to 6	6 to 10	10 to 24	0 to 30	30 to 60	60 to 100	100 to 150	150	0.05/10
Tolerance	±0.1	±0.15	±0.25	±0.2	±0.3	±0.5	±0.7	±1.0	0.05/10