

***μP Reset Circuits with Long Manual Reset Setup Period*****UM807/821/822 SOT143****General Description**

The UM807/821/822 are low-power microprocessor (μP) supervisory circuits used to monitor power supplies in μP and digital systems. They provide excellent circuit reliability and low cost by eliminating external components and adjustments when used with 5V-powered or 3V-powered circuits. The UM807/821/822 also provide a debounced manual reset input with long setup period.

On all devices, the reset output asserts when the V<sub>CC</sub> supply voltage drops below its specified threshold. The reset output remains asserted for the reset timeout period (240ms typ) after V<sub>CC</sub> rises above the reset threshold. The reset output is one-shot pulse asserted for the reset timeout period (140ms min) when manual reset input is held low for a fixed setup timeout period. These devices ignore manual reset transitions of less than the fixed setup timeout period.

The UM807 has an active-low  $\overline{\text{RESET}}$  with open-drain output, the UM821 has an active-low  $\overline{\text{RESET}}$  with push-pull output, and the UM822 has an active-high RESET with push-pull output. These devices, offered in small SOT143 package, are fully guaranteed over the extended temperature range (-40°C to +85°C).

**Applications**

- Set-Top Boxes
- Consumer Electronics
- DVD Players
- Cable/DSL Modems
- MP3 Players
- Industrial Equipments
- Automotive
- Medical Devices

**Features**

- No External Components
- V<sub>CC</sub> Transient Immunity
- Correct Logic Output Guaranteed to V<sub>CC</sub>=1.0V
- Precision V<sub>CC</sub> Monitoring of 3.0V, 3.3V and 5.0V Supplies
- 2μA Supply Current
- 140ms Minimum Power-On Reset Pulse Width
- Available in 3 Manual Reset Setup Periods (t<sub>MR</sub>):  
A: 10.08s  
B: 6.72s  
C: 1.68s
- Available in 3 Output Configurations:  
Open-Drain Active-Low  $\overline{\text{RESET}}$  Output (UM807);  
Push-Pull Active-Low  $\overline{\text{RESET}}$  Output (UM821)  
Push-Pull Active-High RESET Output (UM822)
- 4-Pin SOT143 Package
- Wide Operation Temperature: -40°C to +85°C

## Pin Configurations

## Top View

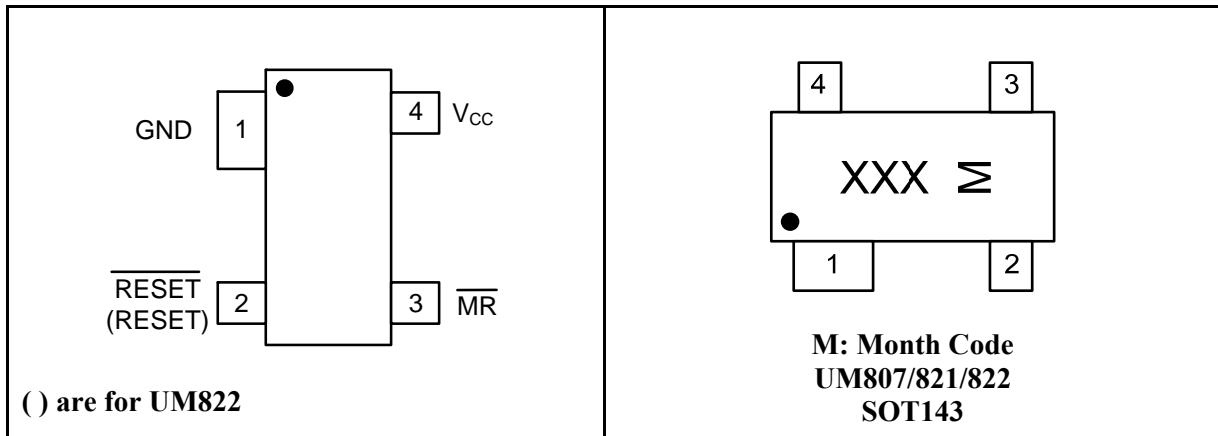

## Ordering Information

### UM8 XX Z T P

#### XX: Output Type

=07 Open-Drain Active Low

=21 Push-Pull Active Low

=22 Push-Pull Active High

#### Z: Reset Threshold (V)

=L 4.63

=M 4.38

=J 4.00

=T 3.08

=S 2.93

=R 2.63

=Z 2.32

#### T: Manual Reset Setup Period (s)

=A 10.08

=B 6.72

=C 1.68

#### P: Package Type

=E SOT143

**Typical Operating Circuit**

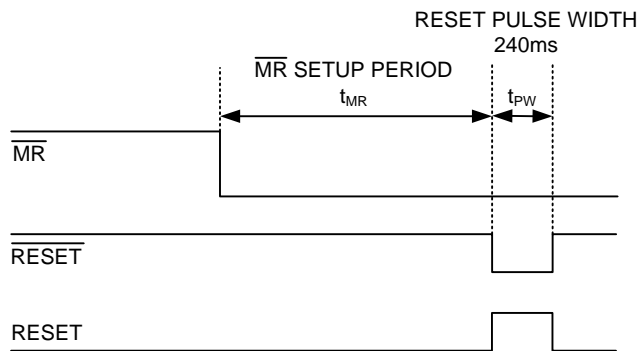
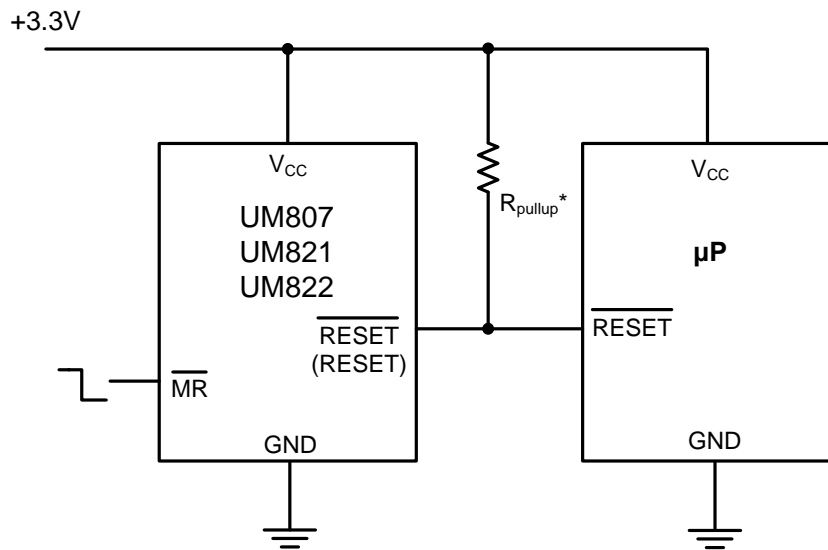

**\*UM807 ONLY**  
**( ) are for UM822**

## Pin Description

Pin Number	Pin Name	Function
1	GND	Ground
2	$\overline{\text{RESET}}$ (UM807/821)	Active-Low Push-Pull or Open-Drain Output. $\overline{\text{RESET}}$ changes from high to low when $V_{CC}$ drops below its reset threshold and remains low for the 240ms reset timeout period after $V_{CC}$ exceeds their reset threshold. $\overline{\text{RESET}}$ is one-shot pulsed low for the reset timeout period (140ms min) after the manual reset input is asserted longer than the specified setup period. For the open-drain output, use a pull-up resistor to $V_{CC}$ . <b>See Figure 1.</b>
	RESET (UM822)	Active-High Push-Pull Output. RESET changes from low to high when $V_{CC}$ drops below its reset threshold and remains high for the 240ms reset timeout period after $V_{CC}$ exceeds their reset threshold. RESET is one-shot pulsed high for the reset timeout period (140ms min) after the manual reset input is asserted longer than the specified setup period. <b>See Figure 1.</b>
3	$\overline{\text{MR}}$	Manual Reset Input, Active Low. Internal 22k $\Omega$ pull-up to $V_{CC}$ . Pull $\overline{\text{MR}}$ low for the typical input pulse width ( $t_{MR}$ ) to one-shot pulse RESET for the reset pulse width ( $t_{PW}$ ). <b>See Figure 2.</b>
4	$V_{CC}$	+5V, +3.3V, or +3V Supply Voltage

## Absolute Maximum Ratings (Note 1)

Symbol	Parameter	Value	Unit
$V_{CC}$	Supply Voltage	-0.3 to +6.0	V
	RESET, $\overline{\text{RESET}}$ (Push-Pull)	-0.3 to ( $V_{CC}+0.3$ )	
	$\overline{\text{RESET}}$ (Open-Drain)	-0.3 to +6.0	
	$\overline{\text{MR}}$	-0.3 to +6.0	
$I_{CC}$	Input Current, $V_{CC}$ , $\overline{\text{MR}}$	20	mA
$I_O$	Output Current, RESET, $\overline{\text{RESET}}$	20	mA
$P_D$	Continuous Power Dissipation (Derate 4mW/ $^{\circ}\text{C}$ above 70 $^{\circ}\text{C}$ )	320	mW
$T_A$	Operating Temperature Range	-40 to +105	$^{\circ}\text{C}$
$T_{STG}$	Storage Temperature Range	-65 to +160	$^{\circ}\text{C}$
	Lead Temperature (Soldering, 10s)	+300	$^{\circ}\text{C}$

Note 1: Stresses beyond those listed under “Absolute maximum Ratings” may cause permanent damage to the device. These are stress ratings only and functional operation of the device at these or any other conditions beyond those indicated in the operational sections of the specifications are not implied. Exposure to absolute maximum rating conditions for extended periods may affect device reliability.

## Electrical Characteristics

( $V_{CC}=5V$  for L/M/J versions,  $V_{CC}=3.3V$  for T/S versions,  $V_{CC}=3V$  for R version, and  $V_{CC}=2.5V$  for Z version,  $T_A=-40^{\circ}C$  to  $+85^{\circ}C$ , unless otherwise noted. Typical values are at  $T_A=+25^{\circ}C$ .) (Note 2)

Symbol	Parameter	Conditions	Min	Typ	Max	Unit	
$V_{CC}$	Supply Voltage Range		1.0		5.5	V	
$I_{CC}$	Supply Current			2.0	5.0	$\mu A$	
$V_{TH+}$	Reset Threshold	L Version	$T_A=+25^{\circ}C$	4.56	4.63	4.70	V
			$T_A=-40^{\circ}C$ to $+85^{\circ}C$	4.50		4.75	
		M Version	$T_A=+25^{\circ}C$	4.31	4.38	4.45	
			$T_A=-40^{\circ}C$ to $+85^{\circ}C$	4.25		4.50	
		J Version	$T_A=+25^{\circ}C$	3.93	4.00	4.06	
			$T_A=-40^{\circ}C$ to $+85^{\circ}C$	3.89		4.10	
		T Version	$T_A=+25^{\circ}C$	3.04	3.08	3.11	
			$T_A=-40^{\circ}C$ to $+85^{\circ}C$	3.00		3.15	
		S Version	$T_A=+25^{\circ}C$	2.89	2.93	2.96	
			$T_A=-40^{\circ}C$ to $+85^{\circ}C$	2.85		3.00	
		R Version	$T_A=+25^{\circ}C$	2.59	2.63	2.66	
			$T_A=-40^{\circ}C$ to $+85^{\circ}C$	2.55		2.70	
		Z Version	$T_A=+25^{\circ}C$	2.28	2.32	2.35	
			$T_A=-40^{\circ}C$ to $+85^{\circ}C$	2.25		2.38	
	Reset Threshold Tempco			150		ppm/ $^{\circ}C$	
$t_{RD}$	$V_{CC}$ to Reset Delay (Note 3)			10		$\mu s$	
$t_{RP}$	Reset Active Timeout Period		140	240	560	ms	
$t_{MR}$	$\overline{MR}$ Minimum Pulse Width	A	6.04	10.08	14.11	s	
		B	4.03	6.72	9.41		
		C	1.01	1.68	2.35		
$t_{PW}$	RESET Pulse Width		140	240	560	ms	
	$\overline{MR}$ Glitch Immunity (Note 4)			100		ns	
$V_{IH}$	$\overline{MR}$ Input Threshold	$V_{CC}>V_{TH(MAX)}$ UM807/821/822L_E/M_E/J_E	2.3			V	
$V_{IL}$					0.8		
$V_{IH}$		$V_{CC}>V_{TH(MAX)}$ UM807/821/822T_E/S_E/R_E/Z_E	$0.7 \times V_{CC}$				
$V_{IL}$					$0.25 \times V_{CC}$		
	$\overline{MR}$ Pull-Up Resistance		10	20	30	k $\Omega$	

## Electrical Characteristics (Continued)

( $V_{CC}=5V$  for L/M/J versions,  $V_{CC}=3.3V$  for T/S versions,  $V_{CC}=3V$  for R version, and  $V_{CC}=2.5V$  for Z version,  $T_A=-40^{\circ}C$  to  $+85^{\circ}C$ , unless otherwise noted. Typical values are at  $T_A=+25^{\circ}C$ .) (Note 2)

Symbol	Parameter	Conditions	Min	Typ	Max	Unit
$V_{OH}$	RESET Output Voltage	$I_{SOURCE}=150\mu A$ , $1.8V < V_{CC} < V_{TH(MIN)}$ UM822L_E/M_E/J_E/T_E/S_E/R_E/Z_E	$0.8 \times V_{CC}$			V
$V_{OL}$		$I_{SINK}=1.2mA$ UM822T_E/S_E/R_E/Z_E			0.3	
		$I_{SINK}=3.2mA$ UM822L_E/M_E/J_E			0.4	
$V_{OH}$	RESET Output Voltage	$I_{SOURCE}=500\mu A$ , $V_{CC} > V_{TH(MAX)}$ UM821T_E/S_E/R_E/Z_E	$0.8 \times V_{CC}$			V
$V_{OL}$		$I_{SOURCE}=800\mu A$ , $V_{CC} > V_{TH(MAX)}$ UM821L_E/M_E/J_E	$V_{CC}-1.5$			
		$I_{SINK}=1.2mA$ , $V_{CC}=V_{TH(MIN)}$ UM807/821T_E/S_E/R_E/Z_E			0.3	
		$I_{SINK}=3.2mA$ , $V_{CC}=V_{TH(MIN)}$ UM807/821L_E/M_E/J_E			0.4	
		$I_{SINK}=50\mu A$ , $V_{CC} > 1.0V$			0.3	

**Note 2:** Production testing done at  $T_A=+25^{\circ}C$ ; limits over temperature guaranteed by design only.

**Note 3:** RESET output for UM807/821; RESET output for UM822.

**Note 4:** "Glitches" of 100ns or less typically will not generate a reset pulse.

## Typical Operating Characteristics

( $T_A=+25^{\circ}\text{C}$ , unless otherwise noted.)

**Supply Current vs. Temperature  
(UM821R\_E)**

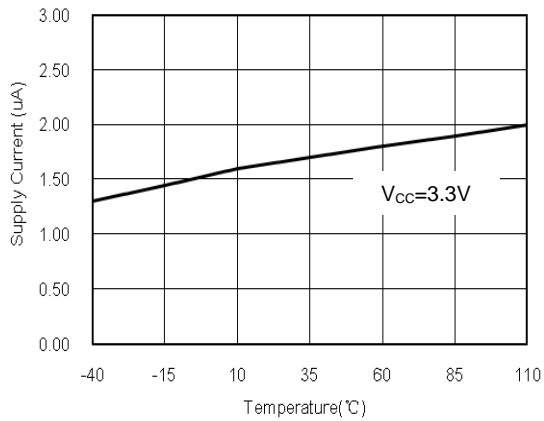

**Power-down RESET Delay vs. Temperature  
(UM821R\_E)**

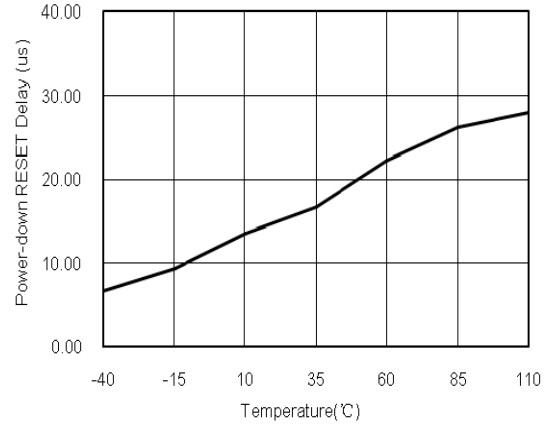

**Power-up RESET Timeout vs. Temperature**

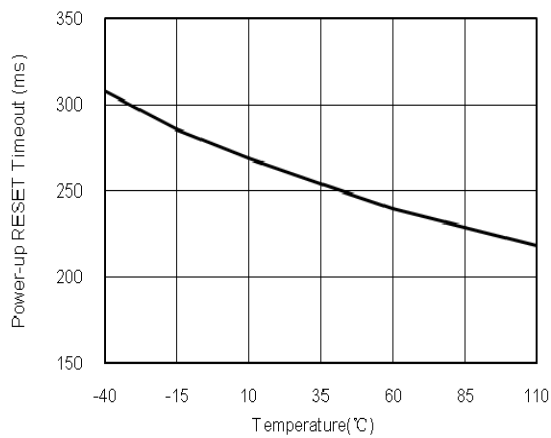

## Detailed Description

### RESET Timing

The reset signal is asserted LOW for the UM821 and HIGH for the UM822 when the power supply voltage falls below the threshold trip voltage and remains asserted for at least 140ms after the power supply voltage has risen above the threshold.

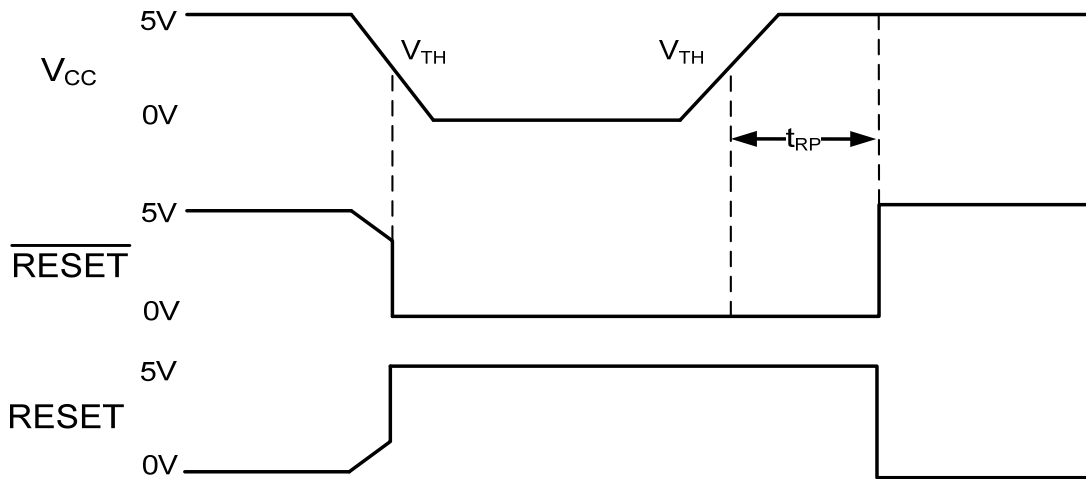

Figure 1. RESET vs. V<sub>CC</sub> Timing Diagram

Pull  $\overline{\text{MR}}$  low for the typical input pulse width (t<sub>MR</sub>) to one-shot pulse  $\overline{\text{RESET}}$  for the reset pulse width (t<sub>PW</sub>).

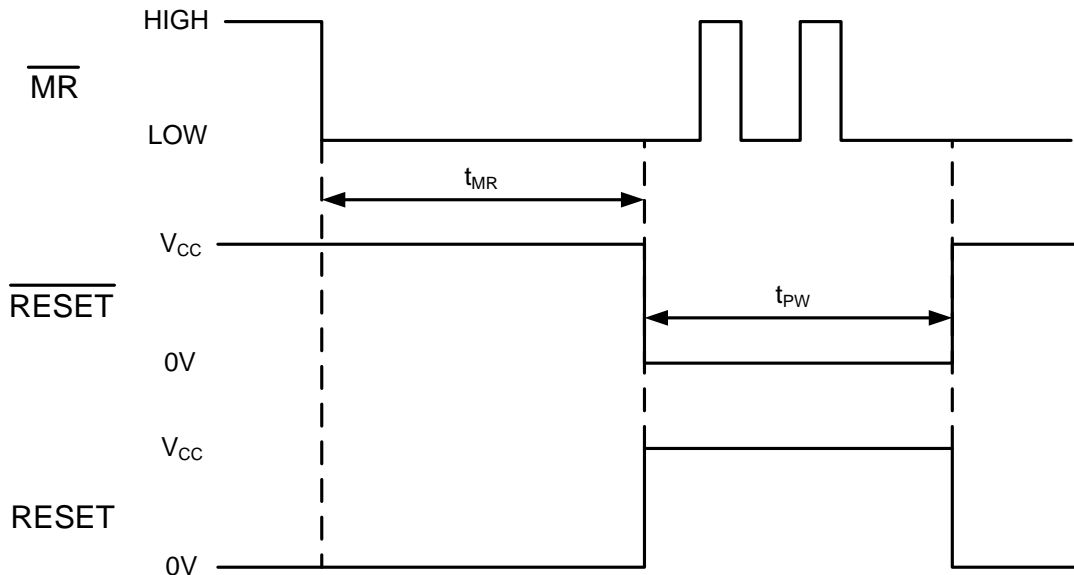

Figure 2. RESET vs.  $\overline{\text{MR}}$  Timing Diagram

### Reset Output

A microprocessor's (μP's) reset input starts the μP in a known state. These μP supervisory circuits



assert reset to prevent code execution errors during power-up, power-down, or brownout conditions.  $\overline{\text{RESET}}$  is guaranteed to be a logic low for  $V_{CC} > 1V$ . Once  $V_{CC}$  exceeds the reset threshold, an internal timer keeps  $\overline{\text{RESET}}$  low for the reset timeout period; after this interval,  $\overline{\text{RESET}}$  goes high.

If a brownout condition occurs ( $V_{CC}$  dips below the reset threshold),  $\overline{\text{RESET}}$  goes low. Any time  $V_{CC}$  goes below the reset threshold, the internal timer resets to zero, and  $\overline{\text{RESET}}$  goes low. The internal timer starts after  $V_{CC}$  returns above the reset threshold, and  $\overline{\text{RESET}}$  remains low for the reset timeout period.

The manual reset input ( $\overline{\text{MR}}$ ) can also initiate a reset. See the *Manual Reset Input* section.

The UM822 has an active-high RESET output that is the inverse of the UM807/821's  $\overline{\text{RESET}}$  output. The UM807 uses an open-drain output, and the UM821/822 have a push-pull output stage. Connect a pull-up resistor on the UM807's  $\overline{\text{RESET}}$  output to any supply between 0 and 6V.

### Manual Reset Input

Each device in the UM807/821/822 family includes one manual reset input, which must be held logic-low for an extended setup period ( $t_{MR}$ ) before the  $\overline{\text{RESET}}$  output asserts. When valid manual reset input conditions/setup periods are met, the  $\overline{\text{RESET}}$  output is one-shot pulse asserted low for a fixed reset pulse width (140ms min). Existing front-panel pushbutton switches (i.e., power on/off, channel up/down, or mode select) can be used to drive the manual reset inputs. The extended manual reset setup period prevents nuisance system resets during normal front-panel usage or resulting from inadvertent short-term pushbutton closure.

This input has an internal 20k $\Omega$  pull-up resistor, so it can be left open if it is not used.  $\overline{\text{MR}}$  can be driven with TTL or CMOS-logic levels, or with open-drain/collector outputs. Connect a normally open momentary switch from  $\overline{\text{MR}}$  to GND to create a manual-reset function; external debounce circuitry is not required. If  $\overline{\text{MR}}$  is driven from long cables or if the device is used in a noisy environment, connecting a 0.1 $\mu\text{F}$  capacitor from  $\overline{\text{MR}}$  to ground provides additional noise immunity.

### Reset Threshold Accuracy

The UM807/821/822 are ideal for systems using a 5V $\pm$ 5% or 3V $\pm$ 5% power supply with ICs specified for 5V $\pm$ 10% or 3V $\pm$ 10%, respectively. They are designed to meet worst-case specifications over temperature. The reset is guaranteed to assert after the power supply falls out of regulation, but before power drops below the minimum specified operating voltage range for the system ICs. The thresholds are pre-trimmed and exhibit tight distribution, reducing the range over which an undesirable reset may occur.

## Applications Information

### Negative-Going $V_{CC}$ Transients

In addition to issuing a reset to the  $\mu P$  during power-up, power-down, and brownout conditions, the UM807/821/822 are relatively immune to short-duration negative-going  $V_{CC}$  transients (glitches). Figure 3 shows typical transient duration vs. reset comparator overdrive, for which the UM807/821/822 do not generate a reset pulse. The graph was generated using a negative-going pulse applied to  $V_{CC}$ , starting above the actual reset threshold and ending below it by the magnitude indicated (reset comparator overdrive). The graph indicates the typical maximum pulse width a negative-going  $V_{CC}$  transient may have without causing a reset pulse to be issued. As the magnitude of the transient increases (goes farther below the reset threshold), the maximum allowable pulse width decreases. Typically, for the UM8\_\_L\_E/M\_E/J\_E, a  $V_{CC}$  transient that goes 125mV below the reset threshold and lasts 40 $\mu s$  or less will not cause a reset pulse to be issued. A 0.1 $\mu F$  capacitor mounted as close as possible to the  $V_{CC}$  provides additional transient immunity.

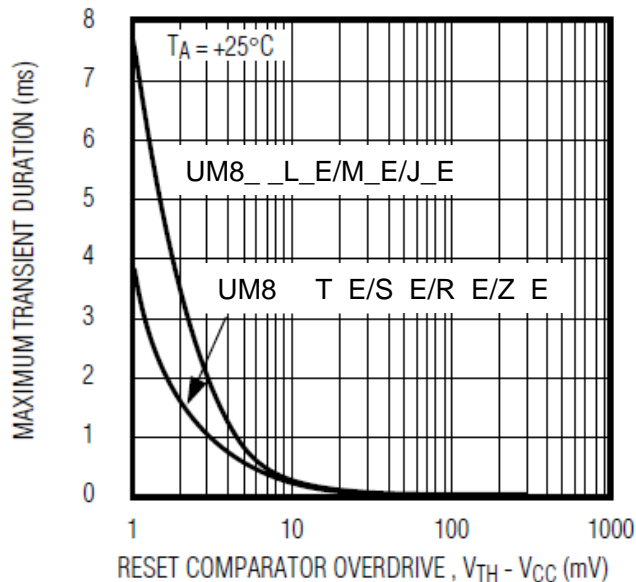
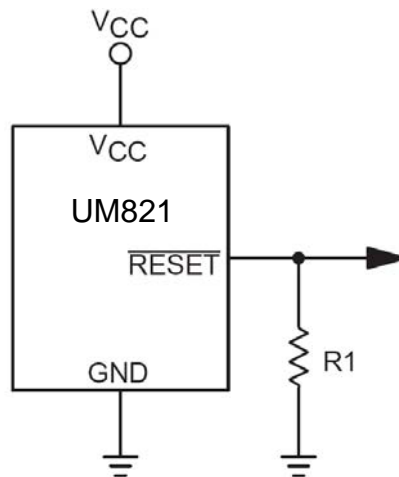

**Figure 3. Maximum Transient Duration without Causing a Reset Pulse vs. Reset Comparator Overdrive**

### Ensuring a Valid $\overline{RESET}$ Output Down to $V_{CC}=0V$

When  $V_{CC}$  falls below 1V, the UM821  $\overline{RESET}$  output no longer sinks current—it becomes an open circuit. Therefore, high-impedance CMOS-logic inputs connected to  $\overline{RESET}$  can drift to undetermined voltages. This presents no problem in most applications since most  $\mu P$  and other circuitry is inoperative with  $V_{CC}$  below 1V. However, in applications where  $\overline{RESET}$  must be valid down to 0V, adding a pull-down resistor to  $\overline{RESET}$  pin will cause any stray leakage currents to flow to ground, holding  $\overline{RESET}$  low (Figure 4). R1's value is not critical; 100k $\Omega$  is large enough not to load  $\overline{RESET}$  and small enough to pull  $\overline{RESET}$  to ground.

A 100k $\Omega$  pull-up resistor to  $V_{CC}$  is also recommended for the UM822 if  $\overline{RESET}$  is required to remain valid for  $V_{CC} < 1V$ .



**Figure 4.  $\overline{\text{RESET}}$  Valid to  $V_{CC}=\text{Ground}$  Circuit**

### Interfacing to $\mu\text{Ps}$ with Bidirectional Reset Pins

$\mu\text{Ps}$  with bidirectional reset pins (such as the Motorola68HC11 series) can contend with the UM821/822 reset outputs. If, for example, the UM821  $\overline{\text{RESET}}$  output is asserted high and the  $\mu\text{P}$  wants to pull it low, indeterminate logic levels may result. To correct such cases, connect a 4.7k $\Omega$  resistor between the UM821  $\overline{\text{RESET}}$  (or UM822  $\overline{\text{RESET}}$ ) output and the  $\mu\text{P}$  reset I/O (Figure 5). Buffer the reset output to other system components.

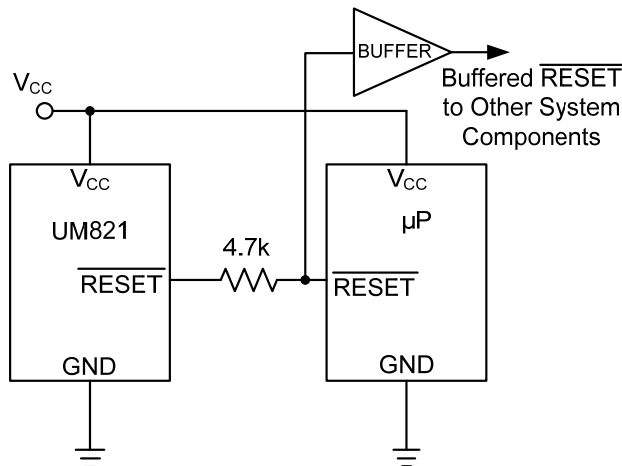

**Figure 5. Interfacing to  $\mu\text{Ps}$  with Bidirectional Reset I/O**

## UM807 Open-Drain $\overline{\text{RESET}}$ Output Allows Use with Multiple Supplies

Generally, the pull-up connected to the UM807 will connect to the supply voltage that is being monitored at the IC's  $V_{CC}$  pin. However, some systems may use the open-drain output to level-shift from the monitored supply to reset circuitry powered by some other supply (Figure 6). Note that as the UM807's  $V_{CC}$  decreases below 1V, so does the IC's ability to sink current at  $\overline{\text{RESET}}$ . Also, with any pull-up,  $\overline{\text{RESET}}$  will be pulled high as  $V_{CC}$  decays toward 0. The voltage where this occurs depends on the pull-up resistor value and the voltage to which it is connected.

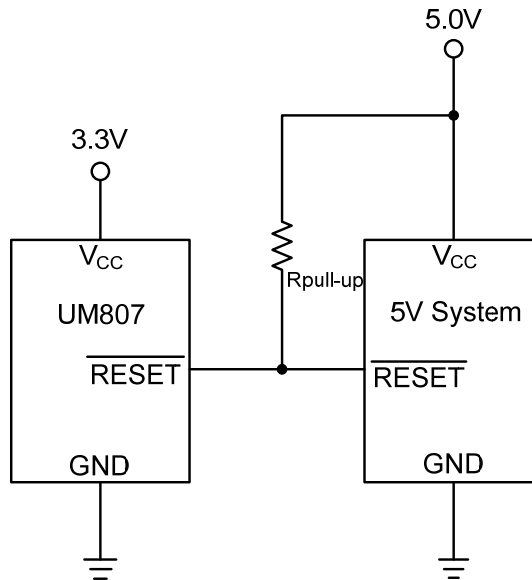
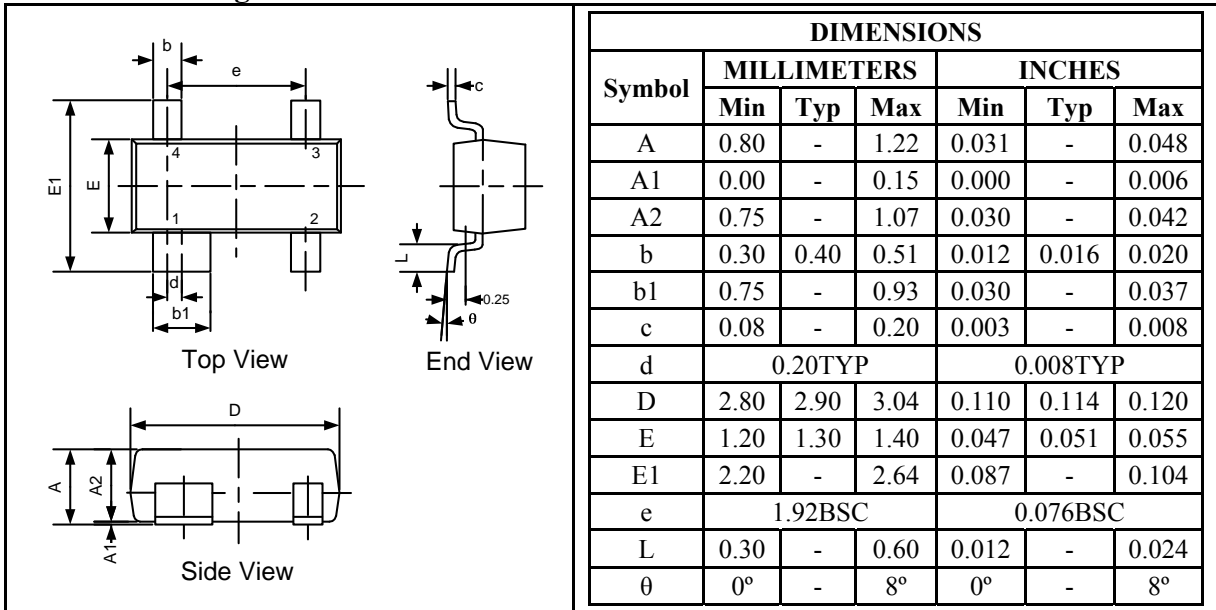

Figure 6. UM807 Open-Drain  $\overline{\text{RESET}}$  Output Allows Use with Multiple Supplies

## Package Information

### UM807/821/822 SOT143

#### Outline Drawing



#### Land Pattern

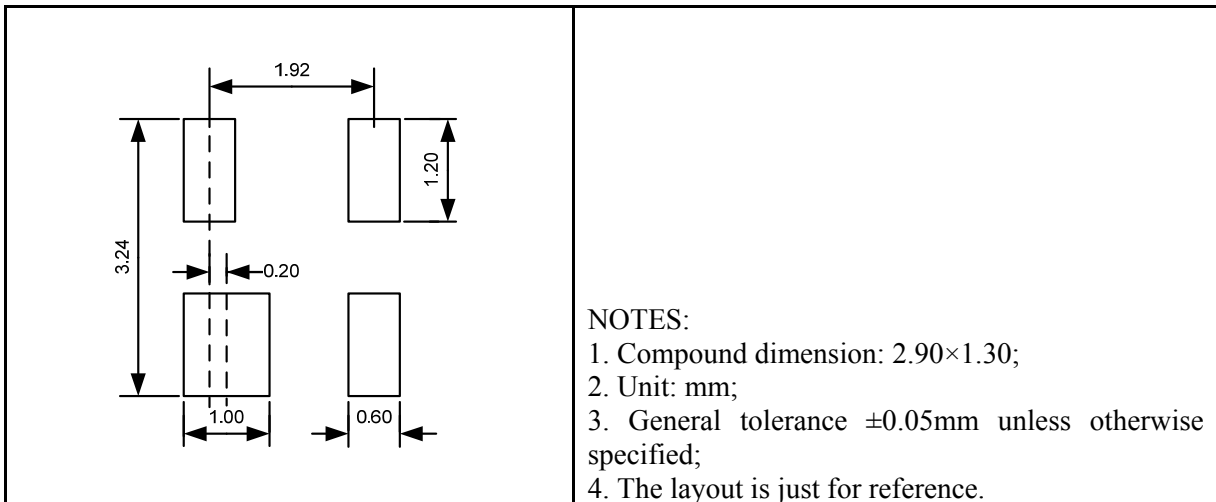

#### Tape and Reel Orientation

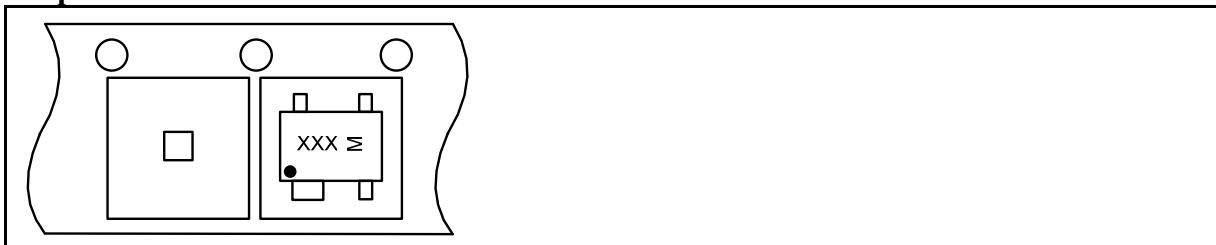

**Selection Table**

Part Number	RESET Threshold (V)	Timeout Period (ms)	Manual Reset Setup Period (s)	Output Type	Marking Code	Package Type	Shipping Qty
UM807LAE	4.63	240	10.08	Open-Drain, Active Low	7LA	SOT143	3000pcs/7Inch Tape & Reel
UM807MAE	4.38	240		Open-Drain, Active Low	7MA		
UM807JAE	4.00	240		Open-Drain, Active Low	7JA		
UM807TAE	3.08	240		Open-Drain, Active Low	7TA		
UM807SAE	2.93	240		Open-Drain, Active Low	7SA		
UM807RAE	2.63	240		Open-Drain, Active Low	7RA		
UM807ZAE	2.32	240		Open-Drain, Active Low	7ZA		
UM807LBE	4.63	240	6.72	Open-Drain, Active Low	7LB		
UM807MBE	4.38	240		Open-Drain, Active Low	7MB		
UM807JBE	4.00	240		Open-Drain, Active Low	7JB		
UM807TBE	3.08	240		Open-Drain, Active Low	7TB		
UM807SBE	2.93	240		Open-Drain, Active Low	7SB		
UM807RBE	2.63	240		Open-Drain, Active Low	7RB		
UM807ZBE	2.32	240		Open-Drain, Active Low	7ZB		
UM807LCE	4.63	240	1.68	Open-Drain, Active Low	7LC		
UM807MCE	4.38	240		Open-Drain, Active Low	7MC		
UM807JCE	4.00	240		Open-Drain, Active Low	7JC		
UM807TCE	3.08	240		Open-Drain, Active Low	7TC		
UM807SCE	2.93	240		Open-Drain, Active Low	7SC		
UM807RCE	2.63	240		Open-Drain, Active Low	7RC		
UM807ZCE	2.32	240		Open-Drain, Active Low	7ZC		

**Selection Table (Continued)**

Part Number	RESET Threshold (V)	Timeout Period (ms)	Manual Reset Setup Period (s)	Output Type	Marking Code	Package Type	Shipping Qty
UM821LAE	4.63	240	10.08	Push-Pull, Active Low	1LA	SOT143	3000pcs/7Inch Tape & Reel
UM821MAE	4.38	240		Push-Pull, Active Low	1MA		
UM821JAE	4.00	240		Push-Pull, Active Low	1JA		
UM821TAE	3.08	240		Push-Pull, Active Low	1TA		
UM821SAE	2.93	240		Push-Pull, Active Low	1SA		
UM821RAE	2.63	240		Push-Pull, Active Low	1RA		
UM821ZAE	2.32	240		Push-Pull, Active Low	1ZA		
UM821LBE	4.63	240	6.72	Push-Pull, Active Low	1LB		
UM821MBE	4.38	240		Push-Pull, Active Low	1MB		
UM821JBE	4.00	240		Push-Pull, Active Low	1JB		
UM821TBE	3.08	240		Push-Pull, Active Low	1TB		
UM821SBE	2.93	240		Push-Pull, Active Low	1SB		
UM821RBE	2.63	240		Push-Pull, Active Low	1RB		
UM821ZBE	2.32	240		Push-Pull, Active Low	1ZB		
UM821LCE	4.63	240	1.68	Push-Pull, Active Low	1LC		
UM821MCE	4.38	240		Push-Pull, Active Low	1MC		
UM821JCE	4.00	240		Push-Pull, Active Low	1JC		
UM821TCE	3.08	240		Push-Pull, Active Low	1TC		
UM821SCE	2.93	240		Push-Pull, Active Low	1SC		
UM821RCE	2.63	240		Push-Pull, Active Low	1RC		
UM821ZCE	2.32	240		Push-Pull, Active Low	1ZC		

**Selection Table (Continued)**

Part Number	RESET Threshold (V)	Timeout Period (ms)	Manual Reset Setup Period (s)	Output Type	Marking Code	Package Type	Shipping Qty
UM822LAE	4.63	240	10.08	Push-Pull, Active High	2LA	SOT143	3000pcs/7Inch Tape & Reel
UM822MAE	4.38	240		Push-Pull, Active High	2MA		
UM822JAE	4.00	240		Push-Pull, Active High	2JA		
UM822TAE	3.08	240		Push-Pull, Active High	2TA		
UM822SAE	2.93	240		Push-Pull, Active High	2SA		
UM822RAE	2.63	240		Push-Pull, Active High	2RA		
UM822ZAE	2.32	240		Push-Pull, Active High	2ZA		
UM822LBE	4.63	240	6.72	Push-Pull, Active High	2LB		
UM822MBE	4.38	240		Push-Pull, Active High	2MB		
UM822JBE	4.00	240		Push-Pull, Active High	2JB		
UM822TBE	3.08	240		Push-Pull, Active High	2TB		
UM822SBE	2.93	240		Push-Pull, Active High	2SB		
UM822RBE	2.63	240		Push-Pull, Active High	2RB		
UM822ZBE	2.32	240		Push-Pull, Active High	2ZB		
UM822LCE	4.63	240	1.68	Push-Pull, Active High	2LC		
UM822MCE	4.38	240		Push-Pull, Active High	2MC		
UM822JCE	4.00	240		Push-Pull, Active High	2JC		
UM822TCE	3.08	240		Push-Pull, Active High	2TC		
UM822SCE	2.93	240		Push-Pull, Active High	2SC		
UM822RCE	2.63	240		Push-Pull, Active High	2RC		
UM822ZCE	2.32	240		Push-Pull, Active High	2ZC		



---

## **GREEN COMPLIANCE**

Union Semiconductor is committed to environmental excellence in all aspects of its operations including meeting or exceeding regulatory requirements with respect to the use of hazardous substances. Numerous successful programs have been implemented to reduce the use of hazardous substances and/or emissions.

All Union components are compliant with the RoHS directive, which helps to support customers in their compliance with environmental directives. For more green compliance information, please visit:

[http://www.union-ic.com/index.aspx?cat\\_code=RoHSDeclaration](http://www.union-ic.com/index.aspx?cat_code=RoHSDeclaration)

## **IMPORTANT NOTICE**

The information in this document has been carefully reviewed and is believed to be accurate. Nonetheless, this document is subject to change without notice. Union assumes no responsibility for any inaccuracies that may be contained in this document, and makes no commitment to update or to keep current the contained information, or to notify a person or organization of any update. Union reserves the right to make changes, at any time, in order to improve reliability, function or design and to attempt to supply the best product possible.