

Electrical schematics

RevNo	Revision note	Date	Signature

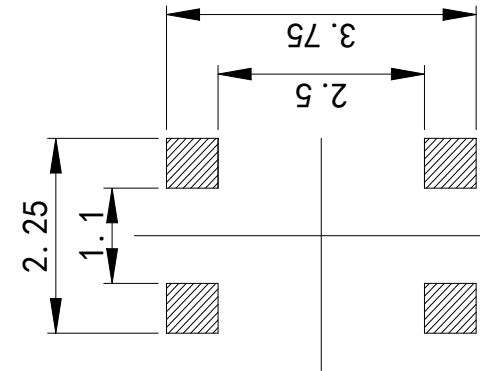

P. C. B LAND DIMENSION

NOTE

- 1. RATING :DC 15V 20mA
- 2. CONTACT RESISTANCE :500m Ω MAX
- 3. GENERAL TOLERANCE : 0.3

YTS13T025	25D03EBBC	1.4±0.1	BLACK	BLACK		100,000 Cycles
MODEL NAME	CODE NO.	"H"	STEM COLOR	CASE COLOR	FORCE	LIFE

YTS13T0251AB00 160gf
YTS13T0252AB00 400gf

Designed by	LUO JIE						
Checked by							
Approved by		Unit	mm	Scale	1/1	Date	2018.11.28
Item	Tactile Switch	Tool	A-Cad	Sheet	1/1	Rev.	0
Model	新四脚小电Stem	Drawing name	ASSEMBLY				