

Specification Sheet for Approved

Customer Name:	
Customer Part No.:	
Ceaiya Part No:	CR4020 Series
Spec No:	L117

【For Customer Approval Only】

If you Approval, Please Stamp

【RoHS Compliant Parts】

Approved By	Checked By	Prepared By
李庆辉	刘志坚	劳水花

深圳市柯爱亚电子有限公司

Shenzhen Ceaiya Electronics Co., Ltd.

地址 1: 深圳市龙华区观湖街道鹭湖社区观盛二路 5 号捷顺科技中心 B706

地址 2: 东莞清溪镇青滨东路 105 号力合紫荆智能制造中心 10 栋

Http://www.szceaiya.com

Tel: 0769-89135516

Fax: 0769-89135519

【Version of Changed Record】

Rev.	Effective Date	Changed Contents	Change Reasons	Approved By
A0	2023.05.25	New release	/	Li qing hui

1. Shape and Dimension (Unit:mm)

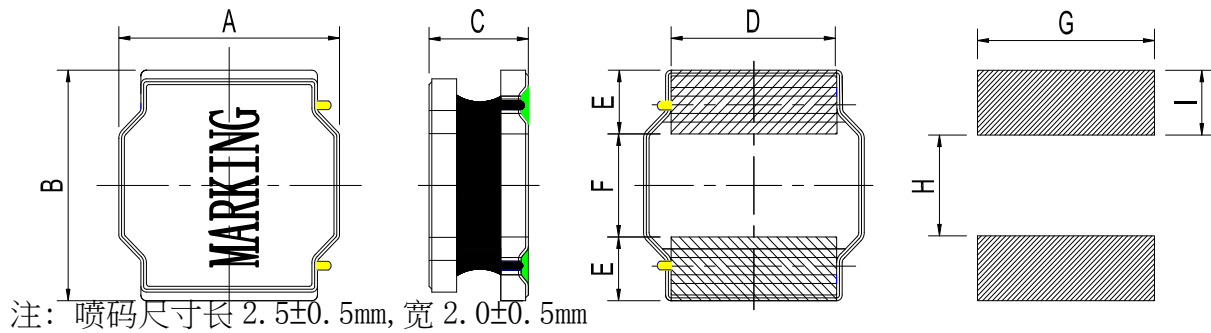

A	B	C	D	E	F	G	H	I
4.0 ± 0.2	4.0 ± 0.2	2.1Max	3.3 ± 0.3	1.0 ± 0.2	2.0 ± 0.3	3.7 Ref	1.9 Ref	1.1 Ref

2. Electronic Characteristics List

Part Number	Inductance (uH)	Tolerance (\pm %)	DCR(m Ω) $\pm 30\%$	Isat (A)	Irise (A)	Test Condition	Marking
CR4020-R33N	0.33	30	13	7.50	3.30	100KHz /0.25V	R33
CR4020-R47N	0.47	30	18	7.50	3.30	100KHz /0.25V	R47
CR4020-R68N	0.68	30	24	7.00	3.20	100KHz /0.25V	R68
CR4020-1R0N	1.0	30	28	5.10	2.15	100KHz /0.25V	1R0
CR4020-1R2N	1.2	30	29	4.70	2.10	100KHz /0.25V	1R2
CR4020-1R5N	1.5	30	35	4.45	1.98	100KHz /0.25V	1R5
CR4020-1R8N	1.8	30	45	4.00	1.90	100KHz /0.25V	1R8
CR4020-2R2M	2.2	20	45	3.40	1.85	100KHz /0.25V	2R2
CR4020-2R7M	2.7	20	53	3.30	1.60	100KHz /0.25V	2R7
CR4020-3R3M	3.3	20	70	3.20	1.40	100KHz /0.25V	3R3
CR4020-4R7M	4.7	20	80	2.35	1.34	100KHz /0.25V	4R7
CR4020-5R6M	5.6	20	95	2.20	1.22	100KHz /0.25V	5R6
CR4020-6R8M	6.8	20	125	2.00	1.04	100KHz /0.25V	6R8
CR4020-8R2M	8.2	20	150	1.75	1.00	100KHz /0.25V	8R2
CR4020-100M	10	20	165	1.60	0.90	100KHz /0.25V	100
CR4020-120M	12	20	175	1.50	0.88	100KHz /0.25V	120
CR4020-150M	15	20	230	1.35	0.77	100KHz /0.25V	150
CR4020-220M	22	20	350	1.05	0.62	100KHz /0.25V	220
CR4020-270M	27	20	476	1.05	0.56	100KHz /0.25V	270
CR4020-330M	33	20	500	0.85	0.49	100KHz /0.25V	330
CR4020-470M	47	20	710	0.74	0.44	100KHz /0.25V	470
CR4020-560M	56	20	800	0.68	0.40	100KHz /0.25V	560
CR4020-680M	68	20	1250	0.60	0.35	100KHz /0.25V	680

※ All test data is referenced to 25° C ambient;

Isat (A): DC Saturation Current that will cause initial inductance to drop approximately 30% max.

Irise(A): DC Current that will cause an approximate ΔT of 40 °C

Measuring Instrument :

L:HIOKI3532-50

DCR:HIOKI 3540

Isat / Irise:HP4284+42841A

3. General Characteristics

3-1. Storage Temperature range : $-40^{\circ}\text{C} \sim +105^{\circ}\text{C}$

3-2. Operating temperature range: $-40^{\circ}\text{C} \sim +125^{\circ}\text{C}$ (Including coil's self temperature rise)

3-3. External appearance : No external defects can be found in the visual inspection.

3-4. Electrode strength : No electrode detachment should be found when the device is pushed in two directions of X and Y with the force of 10.0N for 10 ± 2 seconds after soldering between copper plate and the electrodes.
(Refer to figure at right)

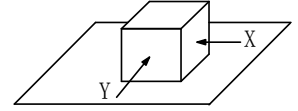

3-5. Vibration test : Inductance deviation is within $\pm 10.0\%$ after 1 hour sweeping vibration in each three directions, namely, forward and backward, up and down, right and left. The frequency is $10 \sim 55 \sim 10\text{Hz}$ and the amplitude of 1 minute cycle is 1.5mm PP.

3-6. Recommended reflow condition:

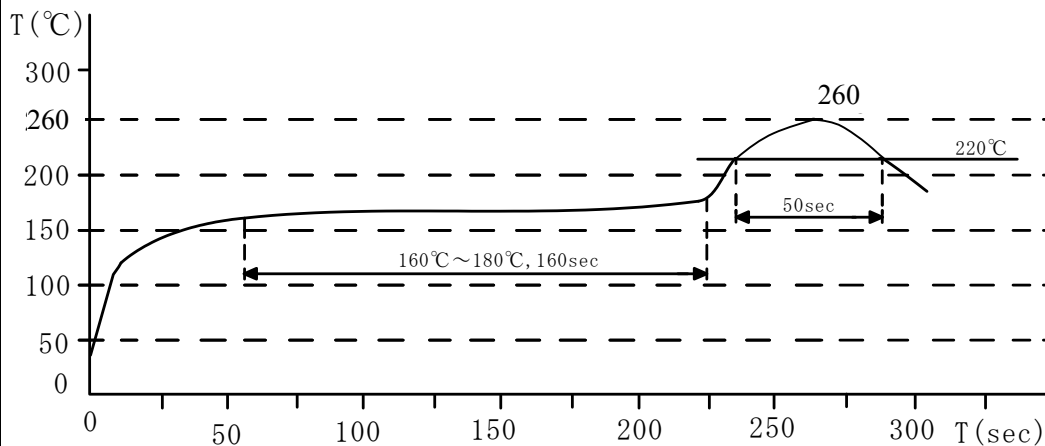

3-7. Humidity test : Inductance deviation is within $\pm 5.0\%$ after 96 ± 4 hours test under the condition of relative humidity of $90 \sim 95\%$ and temperature of $60 \pm 2^{\circ}\text{C}$, and 1 hour storage under room ambient conditions after the device is wiped with dry cloth.

LEAD-FREE



4. Construction and materials

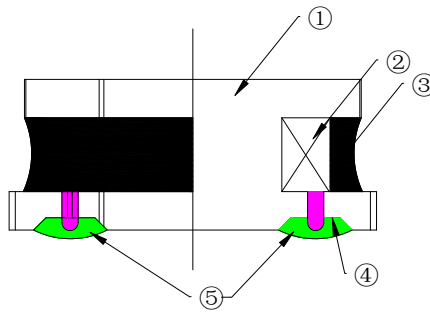

No.	Part name	Material	Ceaiya P/N
①	Drum Core	Ni-Zn Ferrite Core	CY/MT
②	Wire	Polyurethane enameled copper wire	3210200
③	Adhesive	Epoxy Resin Magnetic Powder	7001007
④	Plating Electrodes	Plating: Ag 3-7 μm Ni 1-3 μm Sn 3-7 μm	
⑤	Outer Electrodes	Top surface solder coating Sn99%、 Ag0.3%、Cu0.7%	YX

5.Packaging and Marking:

5-1.Carrier Tape Dimensions:

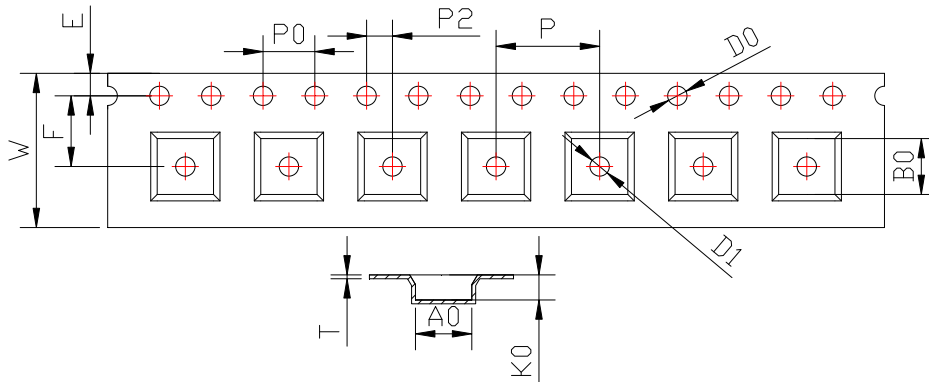

ITEM	W	A0	B0	K0	P	F	E	D0	D1	P0	P2	T
DIM	12.00	4.3	4.3	2.25	8.00	5.50	1.75	1.50	1.50	4.00	2.00	0.30
TOLE	+0.30 -0.10	± 0.1	± 0.1	± 0.1	± 0.1	± 0.1	± 0.1	+0.1	+0.1	± 0.1	± 0.1	± 0.05

5-2. Taping Dimensions:

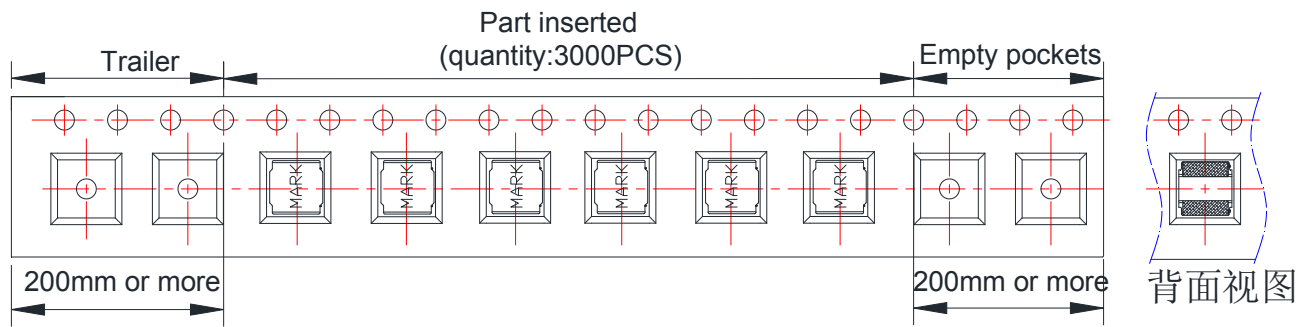

5-3. Reel Dimensions:

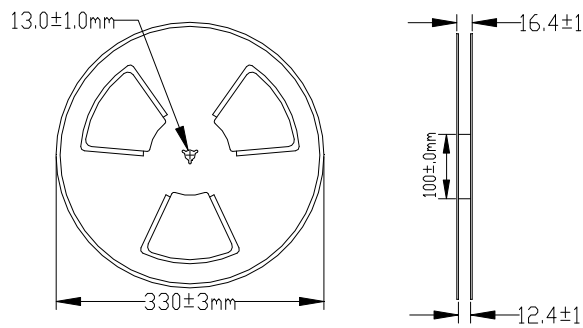

6. PACKAGE SPECIFICATION:

3KPCS/ Reel 9KPCS/ Inner Box 27KPCS/ Outer Box

编带方向，如下图所示

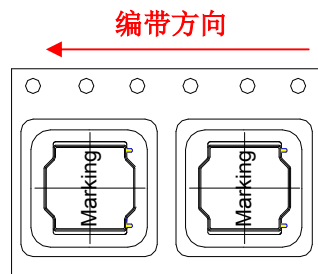

Visual Inspection Standard of Product

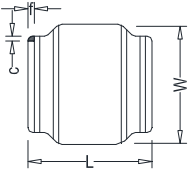
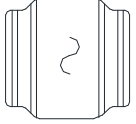
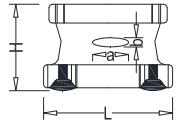
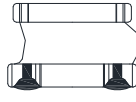
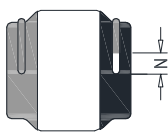
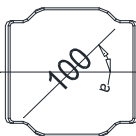
No.	Defect Item	Figure	Rejection Identification	Acceptance
1	Core Defect		The defect length(c or f) more than L/6 or W/6 , NG	AQL=0.65
2	Core Crack		Visual cracks , NG	AQL=0.65
3	Starvation		(1)Resin starved length a more than L/2, NG (2)When $L > 2\text{mm}$, $b > H/2$, NG (3)When $L \leq 2\text{mm}$, b don't control	AQL=0.65
4	Excessive glue		The length, width or height of product beyond specified value, NG	AQL=0.65
5	Cold Solder		(1)For CR2520** Series , cold solder $N > 0.5\text{mm}$, NG (2)For other series, cold solder $N > 1\text{mm}$, NG	AQL=0.65
6	Marking Defect		The marking angle $a > 45^\circ$, NG	AQL=0.65

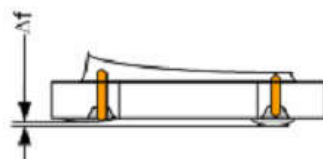

Δf : Clearance between terminal and the surface of plate must be 0.15mm max when coil is placed on a flat plate.