

FXL0640 Series



introduction

- ROHS, Halogen Free and REACH compliance
- High rated current
- 125°C maximum total temperature operation
- 7.3×6.8×4.0mm maximum surface mount package
- Low core loss
- Ultra low buzz noise due to molding construction



Applications

- Laptops and PCs
- Switch and servers
- Base stations
- DC/DC converters
- Battery powered devices
- SSD modules

Product Identification

FXL 0640 --6R8 -M
① ② ③ ④

- ① FXL ----- Series name
- ② 0640 ----- Dimension
- ③ 6R8 ----- Inductance Value (6R8 = 6.8μH)
- ④ M -----Inductance Tolerance (M= ± 20%)

Dimensions (unit:mm)

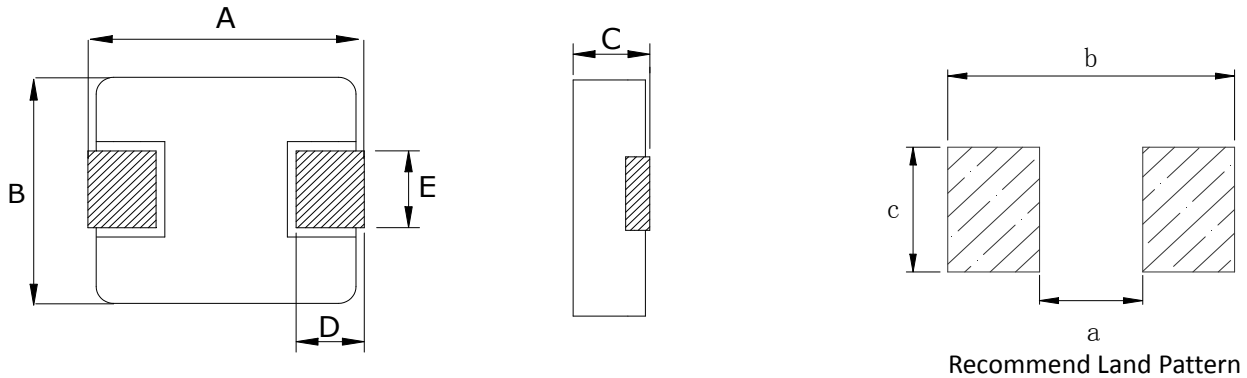

| A | B | C | D | E | a typ | b typ | c typ |
|---------|---------|---------|---------|---------|-------|-------|-------|
| 7.0±0.3 | 6.6±0.2 | 3.8±0.2 | 1.6±0.3 | 3.0±0.3 | 3.7 | 8.4 | 3.5 |

Marking

The inductor is marked with a 3-digit code

| Nominal Inductance | |
|--------------------|---------------|
| Example | Nominal Value |
| 1R0 | 1.0 μ H |
| 100 | 10 μ H |
| 101 | 100 μ H |

Note : Using Ink for marking



Structure and Components

| Symbol | Components | Material |
|--------|------------|--------------------------|
| a | MARKING | Ink (black) |
| b | CORE | Alloy Sponge Powder |
| c | WIRE | Polyurethane copper wire |
| d | Terminal | Copper plated with Sn |

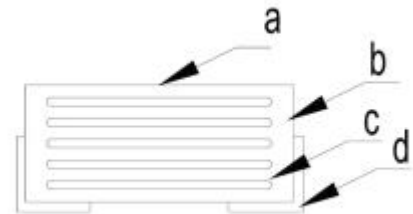

| Part No. | Inductance | DC Resistance | Saturation Current | Heating Rating Current |
|---------------|--------------------|---------------|--------------------|------------------------|
| | L0 (μH) | DCR (mΩ) | Isat (A) | Irms (A) |
| | ±20 %, 100 kHz, 1V | MAX. | TYP. | TYP. |
| FXL0640-R68-M | 0.68 | 4.8 | 19 | 17 |
| FXL0640-1R0-M | 1.0 | 6.6 | 16 | 13.5 |
| FXL0640-1R5-M | 1.5 | 10 | 12.5 | 12.4 |
| FXL0640-2R2-M | 2.2 | 14 | 11 | 10 |
| FXL0640-3R3-M | 3.3 | 20 | 9.5 | 8.5 |
| FXL0640-4R7-M | 4.7 | 30 | 9 | 6.5 |
| FXL0640-6R8-M | 6.8 | 45 | 6.5 | 5.5 |
| FXL0640-8R2-M | 8.2 | 55 | 6 | 5.2 |
| FXL0640-100-M | 10 | 65 | 6 | 4.8 |
| FXL0640-150-M | 15 | 95 | 4.5 | 3.7 |
| FXL0640-220-M | 22 | 125 | 4 | 3.3 |
| FXL0640-330-M | 33 | 240 | 3 | 2.2 |
| FXL0640-470-M | 47 | 320 | 2.5 | 1.8 |

Notes

1. All test data is referenced to 25 °C ambient
2. Operating temperature range - 55 °C to + 125 °C
3. Irms (A):DC current (A) that will cause an approximate ΔT of 40 °C(reference ambient temperature is 25 °C)
4. Isat(A):DC current (A) that will cause L0 to drop approximately 30 %
5. The part temperature (ambient + temp rise) should not exceed 125 °C under worst case operating conditions.
Circuit design, component placement, PWB trace size and thickness, airflow and other cooling provisions all affect the part temperature. Part temperature should be verified in the end application.

| Mechanical Reliability | | |
|--------------------------|--|--|
| Item | Specification and Requirement | Test Method |
| Solderability | 1. No case deformation or change in appearance 2. New solder coverage More than 95% | 1.Preheat: 155℃±5℃ , 60S±2S 2.Tin: lead-free. 3.Temperature:240℃±5℃, flux 3.0S±0.5S. |
| Mechanical shock | 1. No case deformation or change in appearance 2. $\Delta L/L_0 \leq \pm 10\%$ | 1. Acceleration: 100G 2. Pulse time: 6ms 3. 3 times in each positive and negative direction of 3 mutual perpendicular directions |
| Mechanical vibration | 1. No case deformation or change in appearance 2. $\Delta L/L_0 \leq \pm 10\%$ | 1. Reflow: 2times 2. Frequency: 10HZ~55HZ~10HZ, 20 Min/Cycles 3. Amplitude: 1.52 mm 4. Directions: X,Y,Z 5. Time: 12 cycle / direction |
| Endurance Reliability | | |
| Item | Specification and Requirement | Test Method |
| Thermal Shock | Inductance change: Within $\pm 10\%$ Without distinct damage in appearance | 1. First -55℃ for 30 minutes, last 125℃ for 30 minutes as 1 cycle. Go through 1000 cycles. 2. Max transfer time is 3 minutes. 3. Measured at room temperature after placing for 24±2 hours |
| Humidity Resistance | Inductance change: Within $\pm 10\%$ Without distinct damage in appearance | 1.Reflow 2 times, 2.85℃,85%RH,1000 hours 3.Measured at room temperature after placing for 24±2 hours |
| Low temperature storage | Inductance change: Within $\pm 10\%$ Without distinct damage in appearance | 1. Temperature: -55 ± 2℃ 2. Time: 1000 hours 3. Measured at room temperature after placing for 24±2 hours |
| High temperature storage | Inductance change: Within $\pm 10\%$ Without distinct damage in appearance | 1. Temperature: +125 ± 2℃ 2. Time: 1000 hours 3. Measured at room temperature after placing for 24±2 hours |

Recommended Soldering Technologies

(1) Re-flowing Profile

Preheat condition: 150 ~200°C/60~180sec.

Allowed time above 217°C: 80~120sec.

Max temp: 260°C

Max time at max temp: 10 sec.

Solder paste: Sn/3.0Ag/0.5Cu

Allowed Reflow time: 2x max

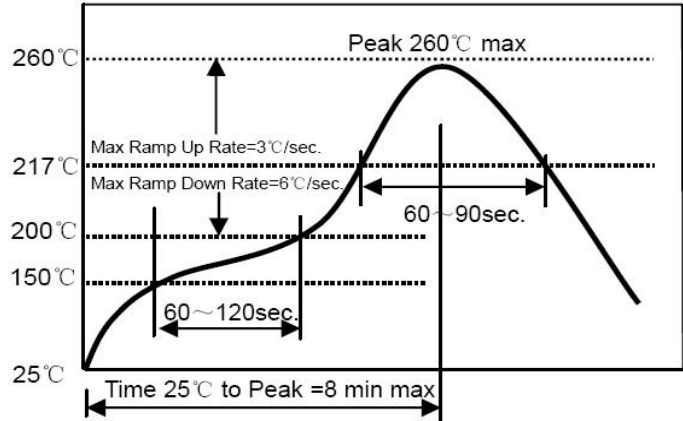

(2) Iron Soldering Profile

Iron soldering power: Max. 30W

Pre-heating: 150°C/60sec.

Soldering Tip temperature: 350°C Max.

Soldering time: 3sec. Max.

Solder paste: Sn/3.0Ag/0.5Cu

Max.1 times for iron soldering

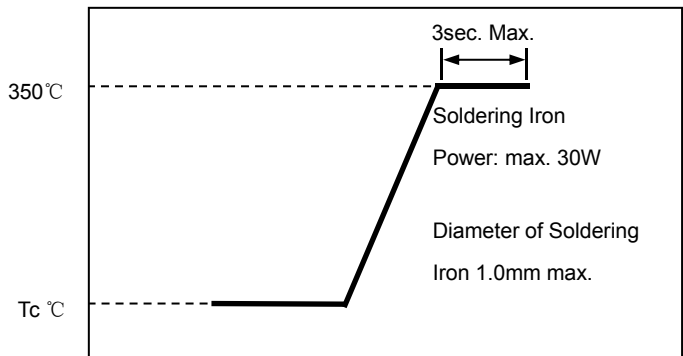

Packaging Information

(1) Tape Packaging Dimensions (Unit: mm)

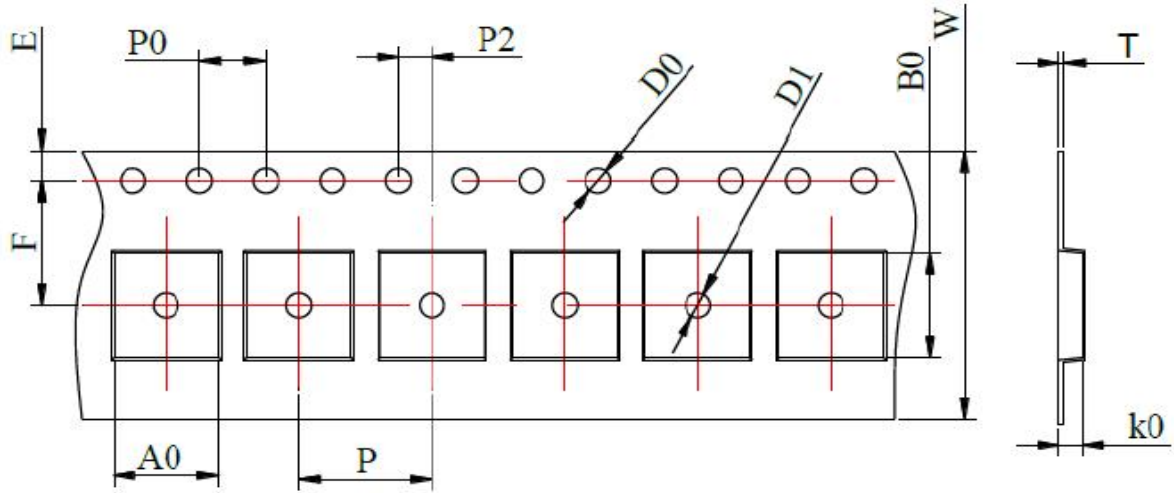

| Type | Tape dimensions (mm) | | | | | | | | | | | |
|---------|----------------------|------------|-----------|-----------|-------------|-------------|--------------|-------------|-------------|-------------|--------------|-------------|
| | W | P | P0 | P2 | D0 | D1 | T | A0 | B0 | K0 | E | F |
| FXL0640 | 16 ±0.3 | 12 ±0.1 | 4 ±0.1 | 2 ±0.1 | 1.5 ±0.1 | 1.5 ±0.1 | 0.4 ±0.05 | 6.9 ±0.1 | 7.5 ±0.1 | 4.3 ±0.1 | 1.75 ±0.1 | 7.5 ±0.1 |

Taping Drawings (UNIT:mm)

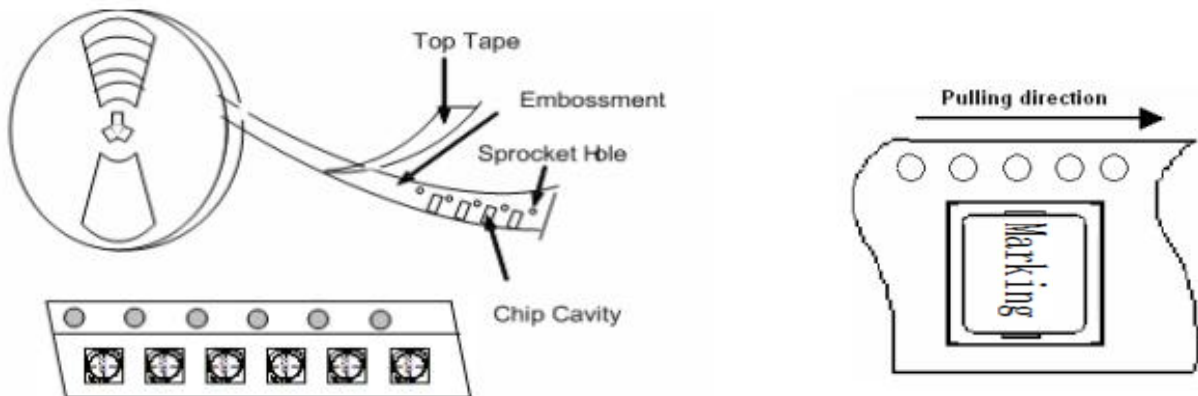

(2) Reel Dimensions (Unit: mm)

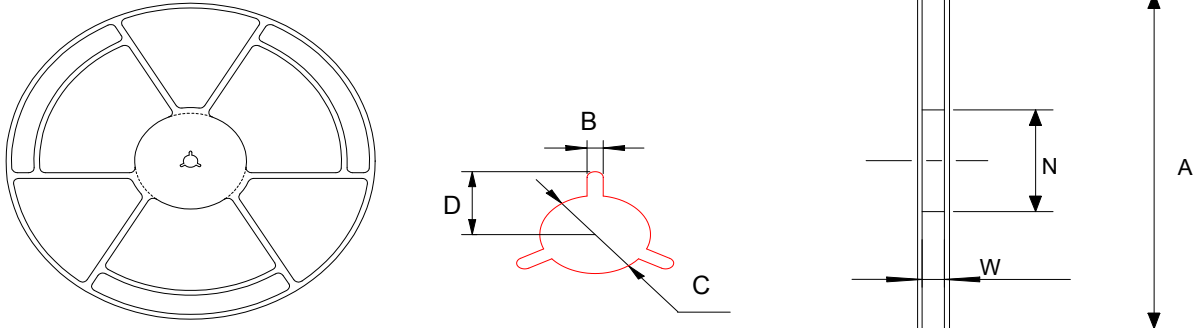

| A | W | N | B | C | D |
|---------|----------|--------|---------|----------|------------|
| 330±2.0 | 16.8±0.2 | 97±0.5 | 2.2±0.5 | 13.2±0.2 | 10.75±0.25 |

(3) Packaging Quantity(PCS)

| Type | Standard Quantity | | |
|---------|-------------------|------------------------|--------------------------------|
| | Reel | Inner box | Carton box |
| FXL0640 | 1000 pcs / reel | 3Reel / box (3000 pcs) | 4 Middle boxes, (12000 pcs) |

(4) Peel force of top cover tape

The peel speed shall be about 300mm/minute

The peel force of top cover tape shall be between 0.1 to 1.3 N

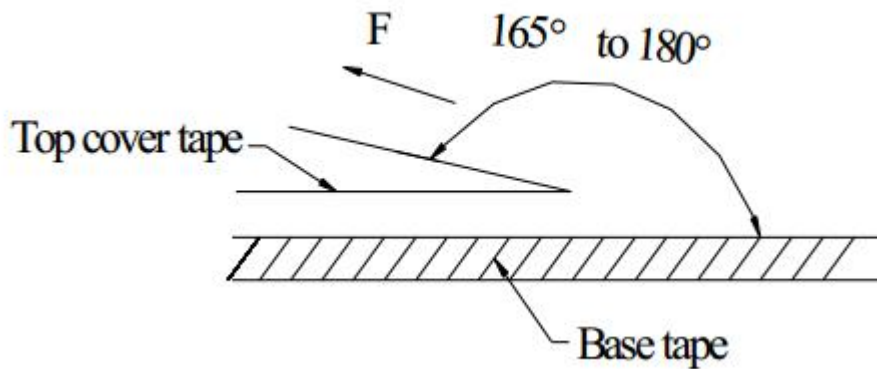

(5) Reel Label

Label on the reel

- Customer's part Number
- Lot Number
- Quantity
- date code

Shipping Label

- Customer's part Number
- Manufacturer's part Number
- Quantity
- date code

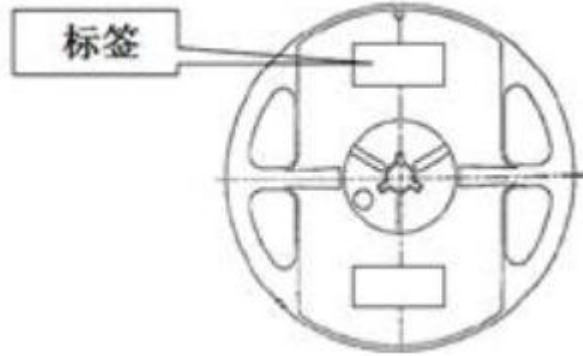

(6) Inner Box

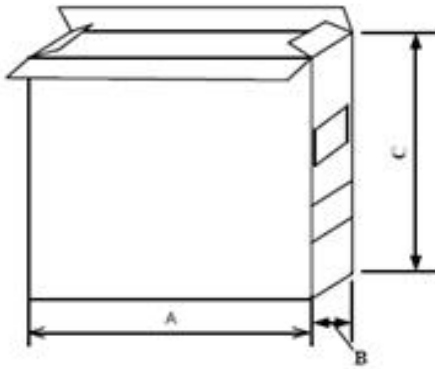

| Packaging type | A (mm) | B (mm) | C (mm) |
|----------------|--------|--------|--------|
| Inner box | 335 | 70 | 340 |

(7) Carton

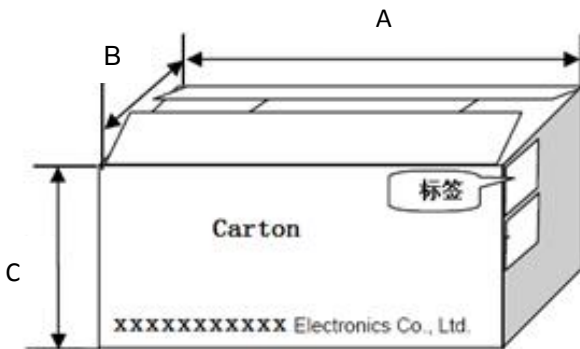

| Packaging type | A (mm) | B (mm) | B (mm) |
|----------------|--------|--------|--------|
| type | 360 | 360 | 360 |