

NO.	ECN NO.	DESCRIPTION	REV.	DRAW	DATE
1.					
2.					
3.					

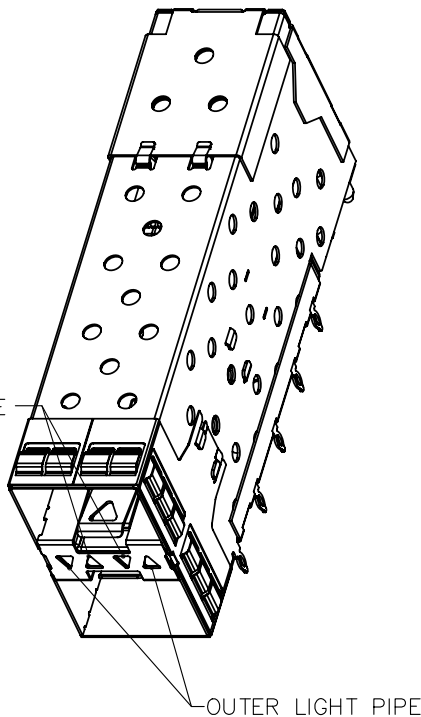
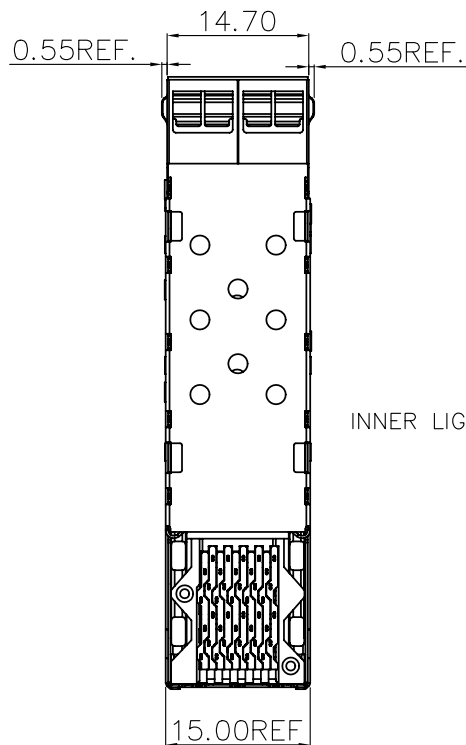
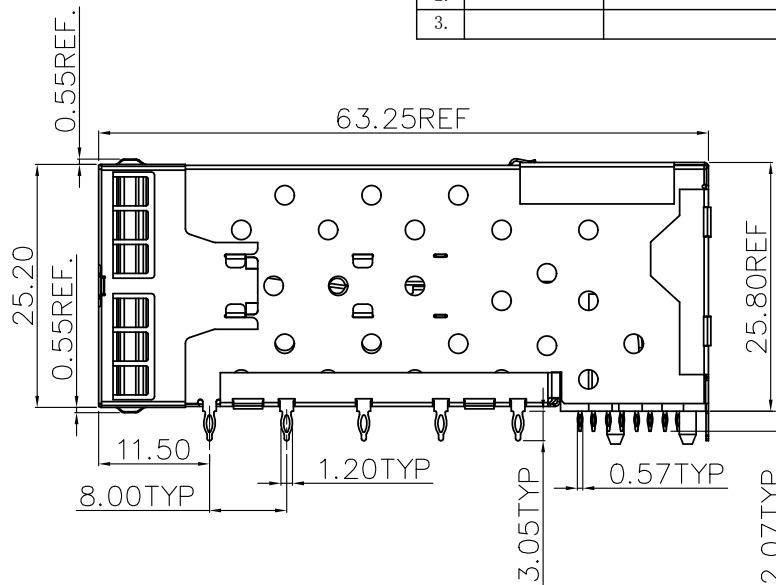
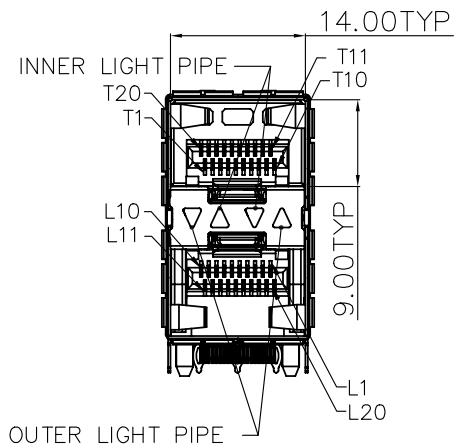

NOTES:

1.MATERIAL:

- CAGE: COPPER ALLOY, THICKNESS: 0.25mm;
- CONNECTOR HOUSING: GLASS FILLED THERMOPLASTIC;
- UL 94V-0 COLOR: BLACK
- TERMINALS: PHOSPHOR BRONZE
- LIGHT PIPE: POLYCARBONATE, CLEAR, UL 94V-0.
- LIGHT PIPE HOUSING: PA46 BLACK, UL 94V-0.

2.FINISH

- TERMINALS CONTACT AREA: PLATED-GOLD;
- SOLDER TERMINAL AREA: PLATED-TIN.

47006-XXXXX1

M31: Ni50u", Au30u",  
规格流水码

产品客户图 Customer Drw		
未注公差 TOLERANCE	.X	±0.35
UNLESS OTHERWISE SPECIFIED	.XX	±0.25
	.XXX	±0.15
	X.°	±2°

**GLGNET**® 深圳市方向电子股份有限公司  
SHEN ZHEN GLGNET ELECTRONICS CO.,LTD.

比例 SCALE	1:1	角法 PROJ.		设计 DESIGN		品名 TITLE	2x1 SFP+ -04 WITH INNER/OUTER LIGHT PIPE
张数 SHEET	1/3	大小 SIZE	A4	校对 CHECKED		料号 ITEM NO.	47006-11M311
单位 UNIT	mm	版本 REV.	C0	核准 APPROVED		图号 DWG NO.	GLG-WS-036

NO.	ECN NO.	DESCRIPTION	REV.	DRAW	DATE
1.					
2.					
3.					

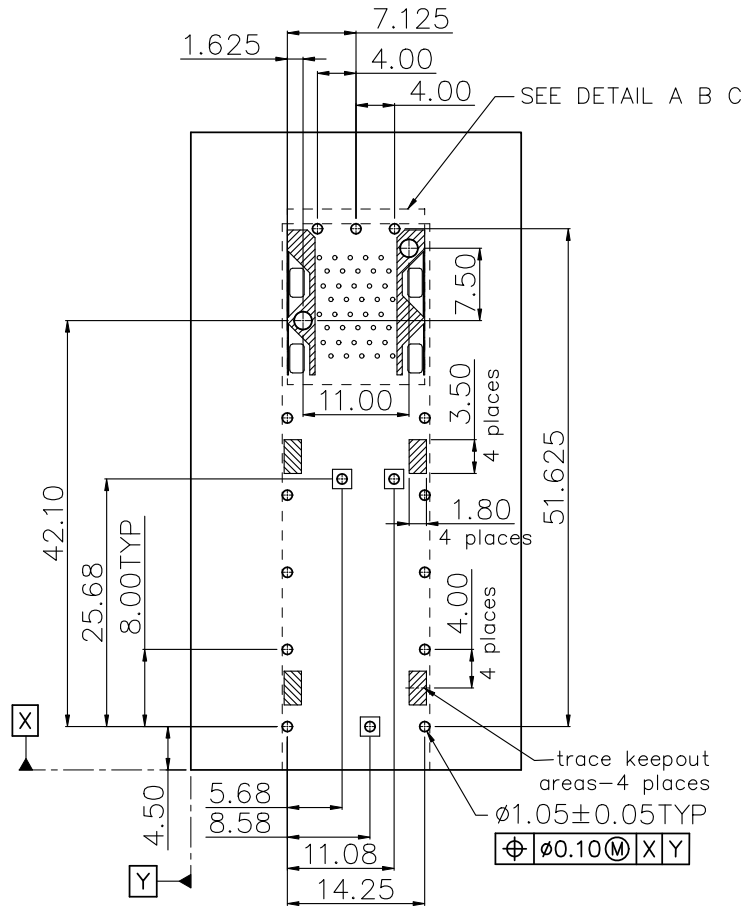

RECOMMENDED PCB LAYOUT AND PCB TOLERANCE ±0.05

1. RECOMMENDED PCB THICKNESS: 2.36 (MINIMUM PCB THICKNESS: 1.57)
2. 考虑客户使用兼容性器件, 回处孔位, 建议PCB LAYOUT图有设计, 但我司此规格器件处无对应引脚.

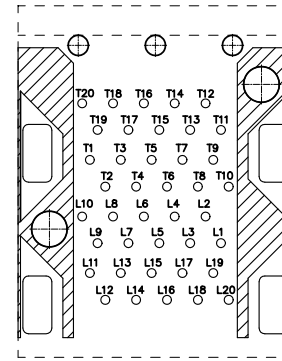

DETAIL A SCALE 2:1

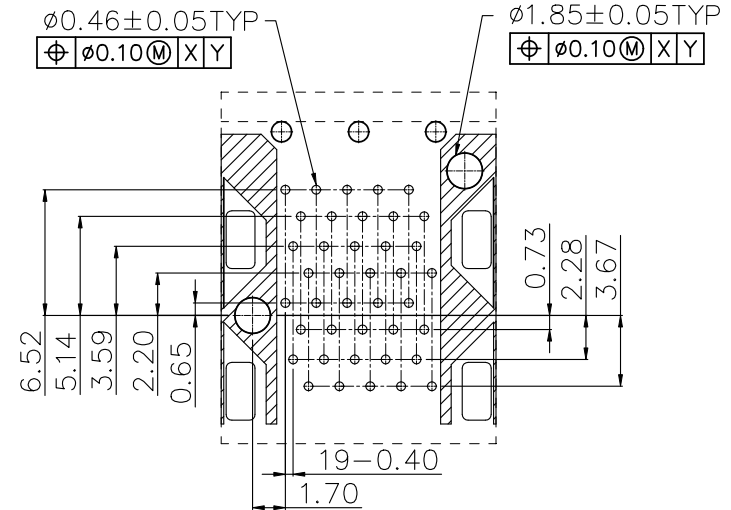

DETAIL B SCALE 2:1

产品客户图 Customer Drw	
未注公差 TOLERANCE UNLESS OTHERWISE SPECIFIED	.X ±0.35 .XX ±0.25 .XXX ±0.15 X.° ±2°

**GLGNET**® 深圳市方向电子股份有限公司  
SHEN ZHEN GLGNET ELECTRONICS CO.,LTD.

比例 SCALE	1:1	角法 PROJ.		设计 DESIGN		品名 TITLE	2x1 SFP+ -04 WITH INNER/OUTER LIGHT PIPE
张数 SHEET	2/3	大小 SIZE	A4	校对 CHECKED		料号 ITEM NO.	47006-11M311
单位 UNIT	mm	版本 REV.	C0	核准 APPROVED		图号 DWG NO.	GLG-WS-036

NO.	ECN NO.	DESCRIPTION	REV.	DRAW	DATE
1.					
2.					
3.					

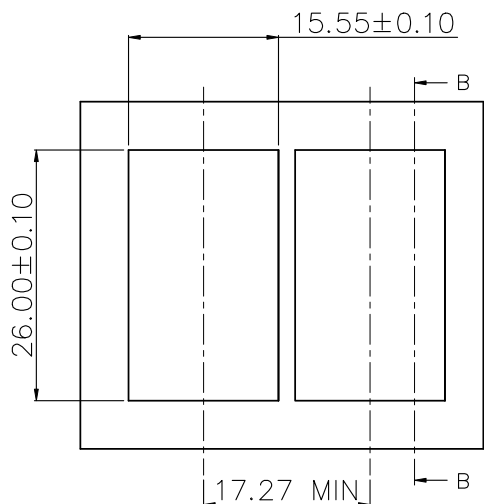

RECOMMENDED PANEL CUTOUT AND PC BOARD  
PANEL POSITION AND THICKNESS 0.8-2.6

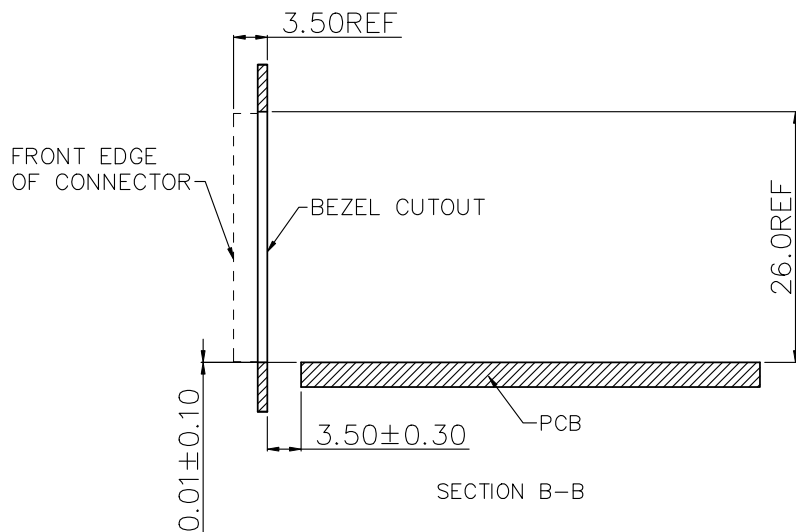

BEZEL OPENING ABOVE  
TOP OF PC BOARD

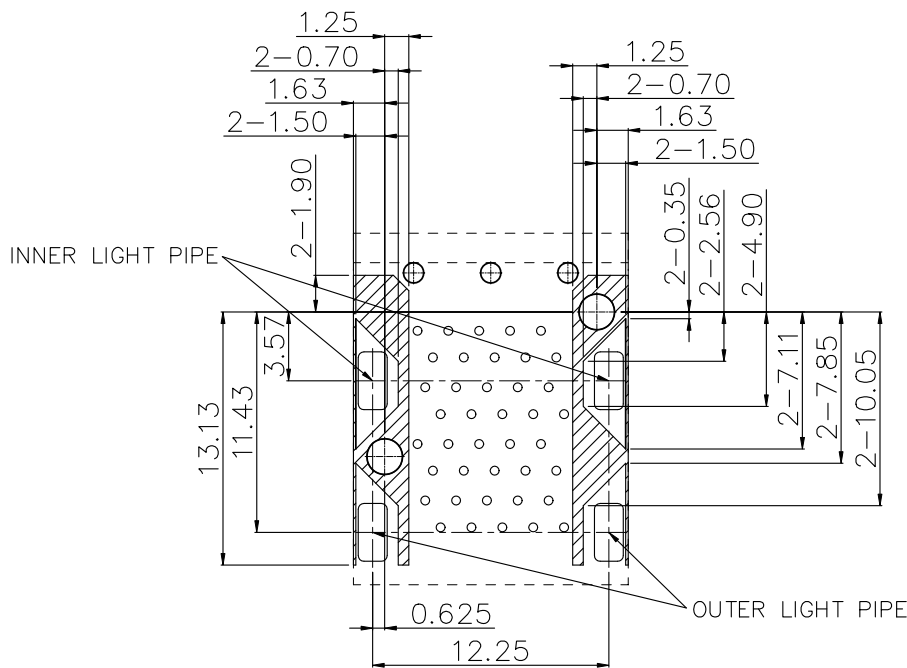

DETAIL C  
SCALE 2:1

产品客户图 Customer Drw		
未注公差 TOLERANCE	.X	±0.35
UNLESS OTHERWISE SPECIFIED	.XX	±0.25
	.XXX	±0.15
	X.°	±2°

**GLGNET**® 深圳市方向电子股份有限公司  
SHEN ZHEN GLGNET ELECTRONICS CO.,LTD.

比例 SCALE	1:1	角法 PROJ.		设计 DESIGN		品名 TITLE	2x1 SFP+ -04 WITH INNER/OUTER LIGHT PIPE
张数 SHEET	3/3	大小 SIZE	A4	校对 CHECKED		料号 ITEM NO.	47006-11M311
单位 UNIT	mm	版本 REV.	C0	核准 APPROVED		图号 DWG NO.	GLG-WS-036