

雅晶鑫電子

Shenzhen Yajingxin Electron Co.,Ltd

Customer	
Production Name	SMD LVDS OSC SEAM 3.2*2.5
Customer P/N	N/A
P/N	F3225100MWFCK2F466
Revision	A
Print Date	2023-06-27

Drawn	Checked	Approved
		



RoHS Compliant

■ Electrical Specifications

1.Model No	3225 LVDS OSC
2.Nominal Frequency:F0	100.000MHz
3.Mode of Oscillation	3 RD Overtone
4.Operating Temperature Range:Top	-40°C to85°C
5.Storage Temperature Range: Tst	-55°C to +125°C
6.Frequency Stability Fdev	±50ppm TYP. ±30PPM CONTACT SALES
7.Power Supply Voltage Vcc	3.3V±10%
8.Current Consumption: I	50mA Max. 9mA typ. @100mhz 3.3v
9.Output Voltage Logic High(VoH)	1.6V MAX, 1.45V typ.
Logic Low(VoL)	0.9V min 1.1V typ.
Vod(OUTP_H-OUTN_L)	250mV-450mV
Vop(OUTP-OUTN)	500mv-900mV
10.Output Load: Cload	100 Ohms
11.Semmetry (at 50%VDD) :Duty	45-55% @CROSS POINT
12.Rise & Fall Time :Tr &Tf	0.5 ns Max.
13.Tri-State Function	Tri-state
14.Output Disable Time	100nsec
15.Output Enable Time(start-up time)	10msec max
16.OE pin input: VinL:	0.3Vcc Max
VinH	70% Vcc Min.
17.RMS Phase Jitter (Integrated 12 kHz ~ 20 MHz)	1 ps max
18.aging per year:	±3ppm/year

Part Number Configuration

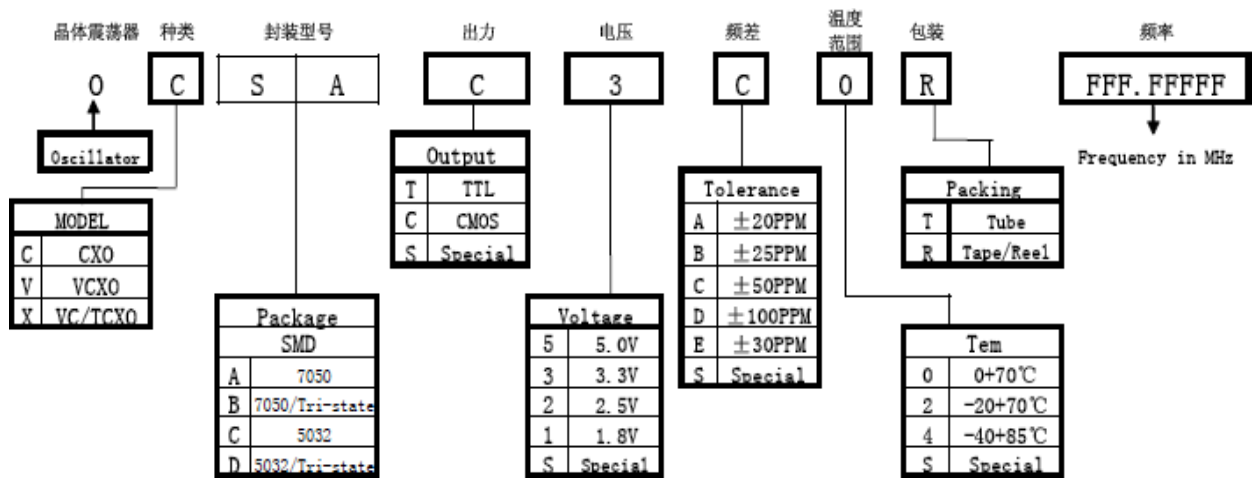

Dimensions

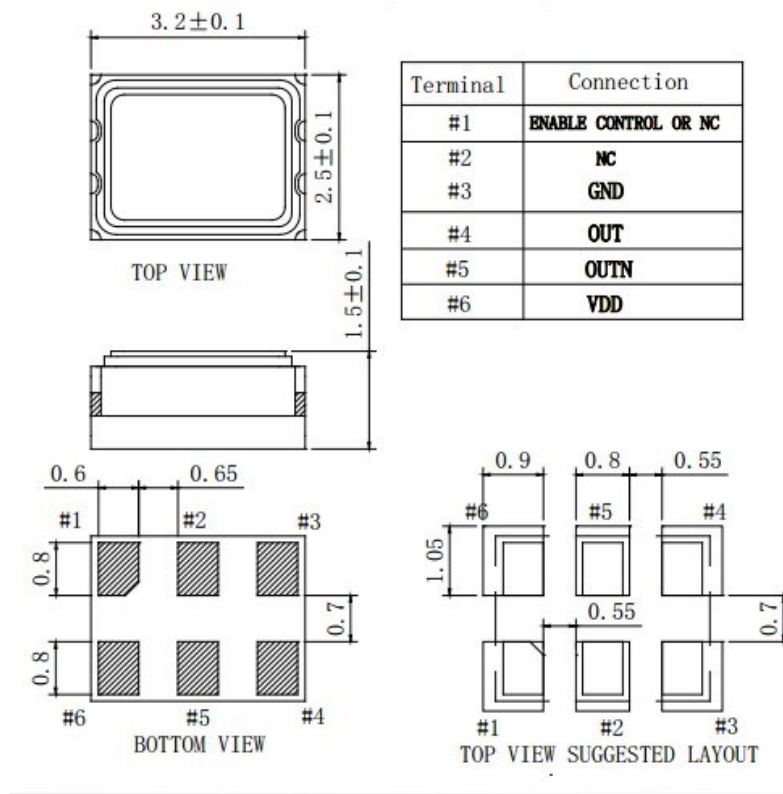

Marking

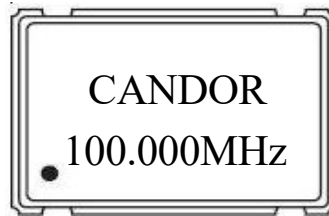

Line 1: CANDOR

Line 2: ●100.000MHz

中间对齐。

■Output Wave Form AND Test diagram,:

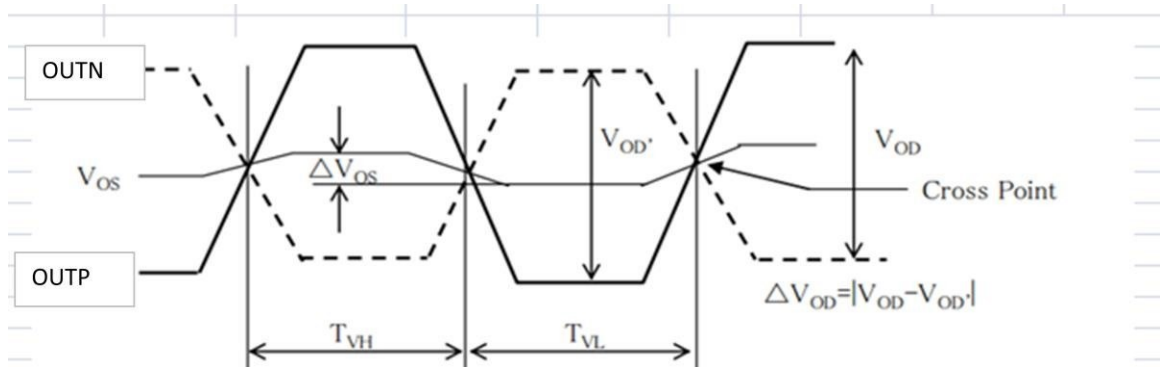

Measuring for Vod.

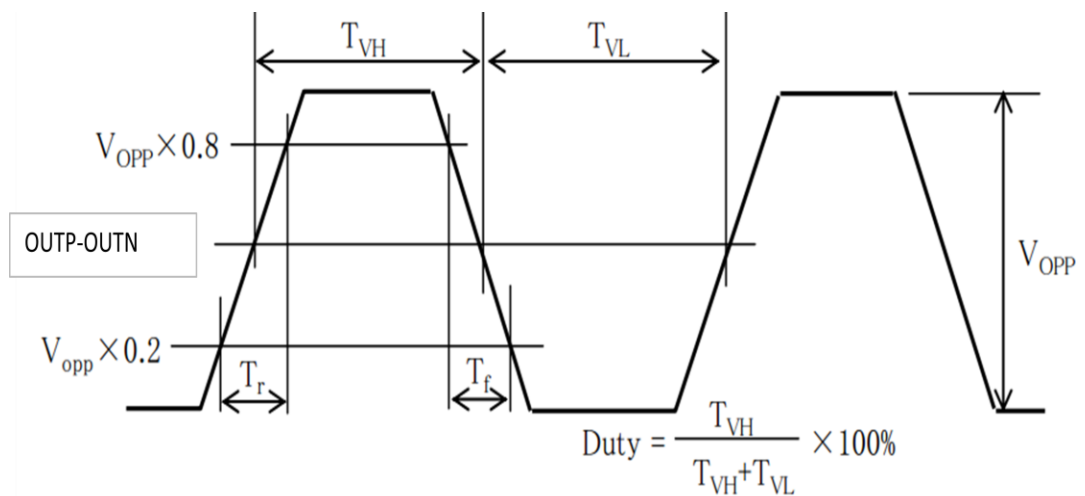

Measuring for Vopp, Tr,Tf,Duty

■Enable/Disable timing:

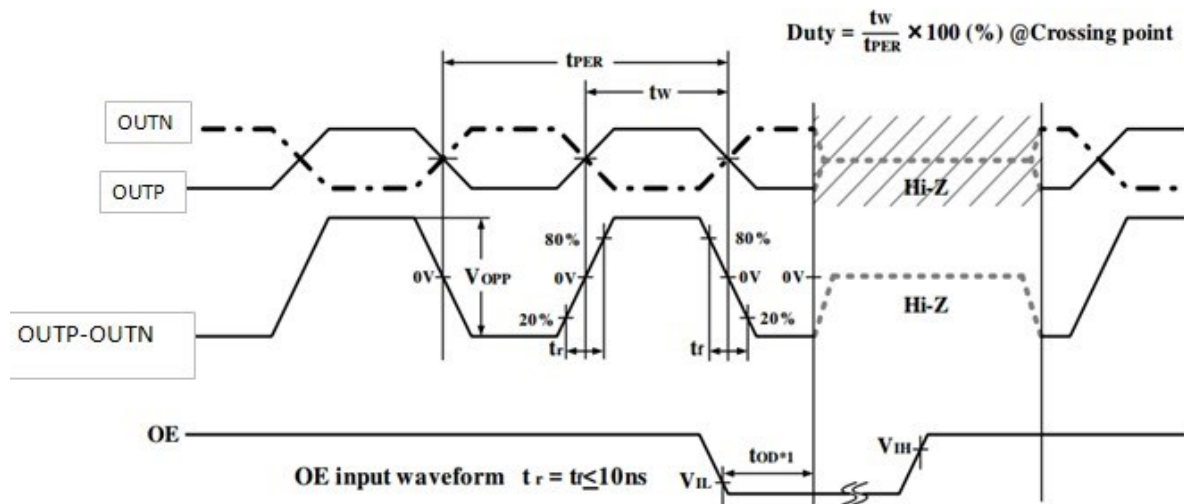

■ Termination Diagrams for Enduser.

LVDS AC Termination

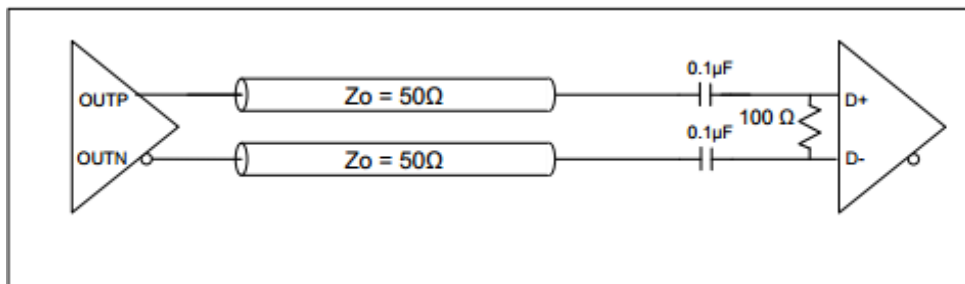

LVDS DC Termination at the Load .

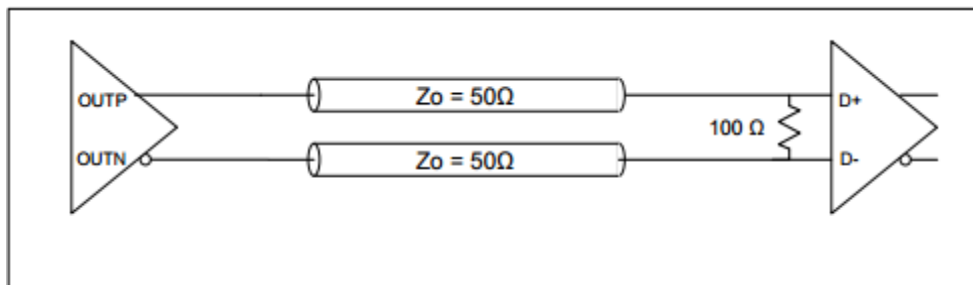

■ Reflow Profile

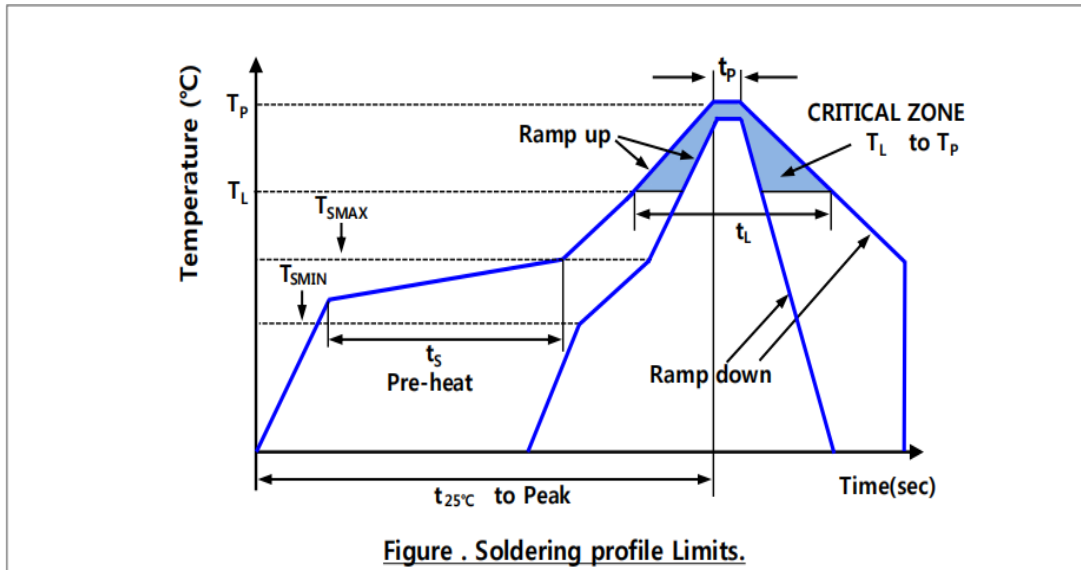

Description	Parameter	Pb-free
Average ramp-up rate	T_{smax} to T_P	3 °C/sec max
Preheat		
Minimum temperature	T_{SMIN}	150 °C
Maximum temperature	T_{SMAX}	200 °C
Time(T_{SMIN} to T_{SMAX})	t_s	60 sec to 180 sec
Ramp-up rate	T_{SMAX} to T_L	1.25 °C/sec
Time maintained above liquidous temperature	t_L	60 sec to 150 sec
Liquidous temperature	T_L	217 °C
Peak temperature	T_P	260 °C
Time within 5 °C of actual peak temperature	t_p	20 sec to 40 sec
Ramp-down rate	T_P to T_{smax}	6 °C/sec max
Time 25 °C ($t_{25^\circ\text{C}}$) to peak temperature	t	8 minutes max

Note:

- 1) Maximum of 3 reflow cycles is recommended In order to minimize device damage:
- 2) ***Do not wash or clean the board after reflow process because of the unit with a vent hole on the back side .**

■ Reliability Specifications

No	Test Item	Test Methods
1	DROP TEST	Device are dropped from a height of 75 cm onto 3 mm thickness stainless plate executing 3 times of random drops.
2	MECHANICAL SHOCK	Device are shocked to half sine wave (1000 G) three mutually perpendicular axes each 3 times.
3	High Temp and Humidity Test	85°C/RH 85%, 500Hrs
4	High temp storage test	125°C+/-2°C 500Hrs
5	Low temp storage test	-40°C 500Hrs
6	Thermal shock test	-40°C~+85°C DWEL 60' 100cycles
7	Aging test	85°C 1000Hrs
8	Resistance to solder heat	260°C 10S
9	VIBRATION	Frequency range 10-2000 Hz Amplitude Sweep 1.5 mm Sweep Time 20 minute Test Time 2 hours
10	SOLDERABILITY	MIL - STD - 20E Method 208C Temperature 245°C±5°C Material H63A (Silver 2-3 %) Immersion depth 0.5 mm minimum Immersion time 3 ± 0.5 seconds Flux Rosin resin methyl

■ Packaging

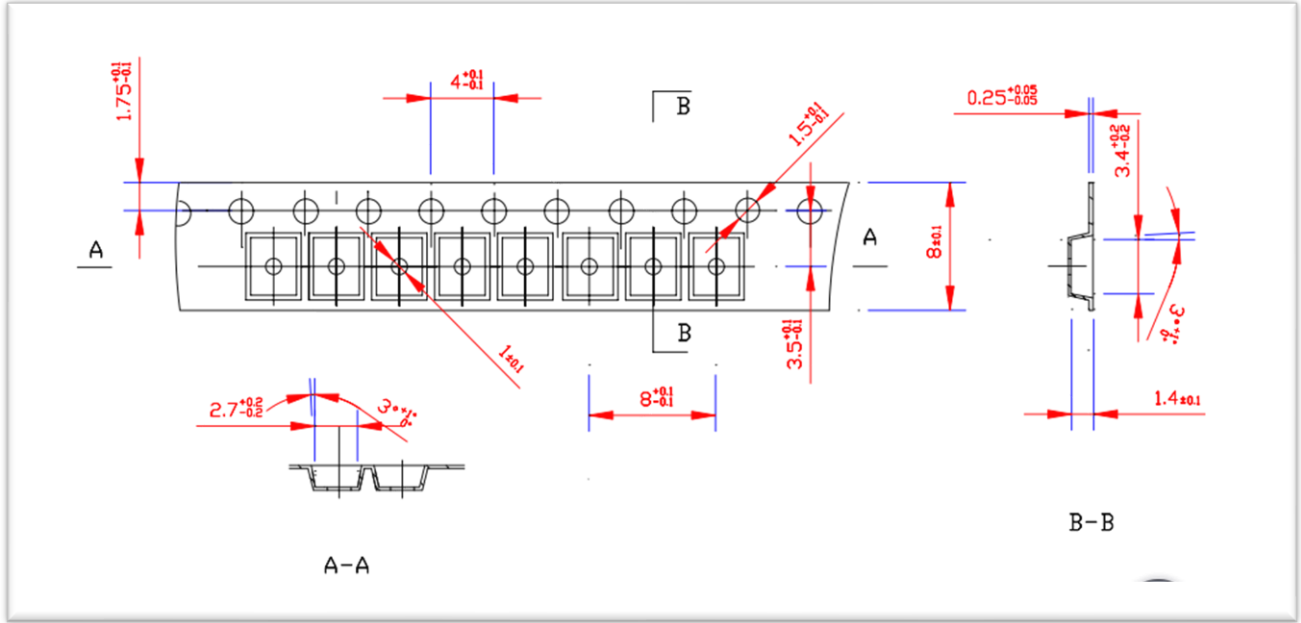

■ Reel Dimension

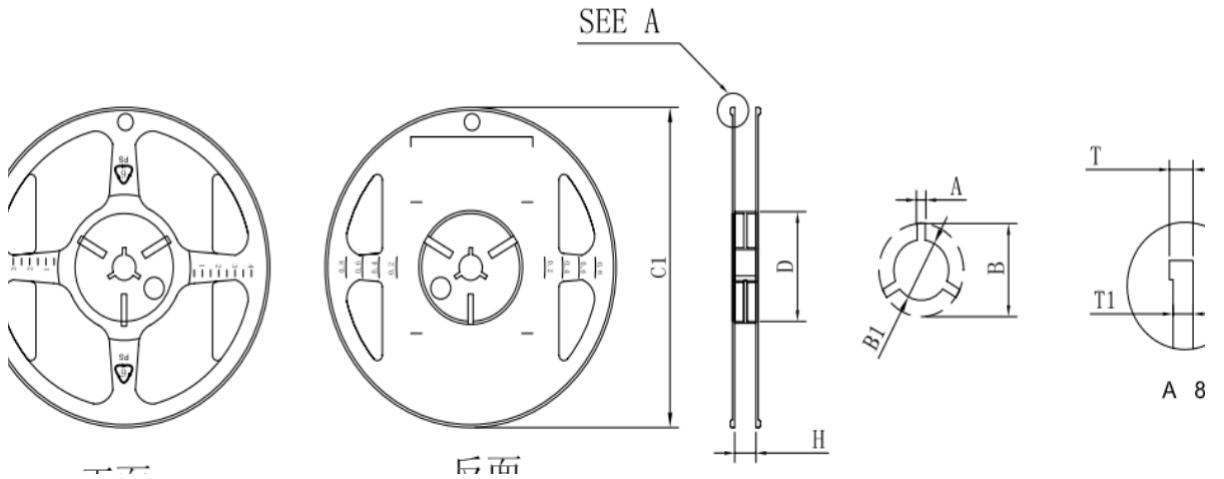

单位: mm

规格	C1±3	H±0.5	A±0.3	B±0.5	B1±0.3	T±0.2	T1±0.2	D±0.5	备注
8mm	178	8.8	2.6	22.5	13.5	2.0	1.6	60.0	

NOTE: QTY 3K/REEL.
