

REV. 版本

01



Specification Confirmation
产品规格书

CUSTOMER (客户): _____

MODEL NO. (型号): _____ DS-S006M

MODEL NAME. (名称): _____ 9g数字铜齿舵机

Please detail check and sign it back before order this product!
在您下单采购本产品之前请您阅读本规格书并在下列承认栏内签字回传!

DS Confirmation 德晟承认栏

Prepared 承认	Checked 审核	Approval 批准
李哲	赖正礼	

Custom Confirmation 客户承认栏

Prepared 承认	Checked 审核	Approval 批准

Revise record 修改记录

REV. 版本	Record detail 记录细节	Date日期
00	初始发行	2020/2/18

东莞市德晟智能科技有限公司

No	Item 项目	Specification 规格	Remarks 备注							
1	Operating Voltage 工作电压范围	4.8-6V DC								
2	Standby Current 静态电流	≤8mA at 6.0V (STD. 标准值)								
3	No Load Current* 空载电流	≤150mA at 4.8V (STD. 参考值)								
		≤170mA at 6.0V (STD. 标准值)								
4	No Load Speed* 空载速度	≤0.13sec/60° at 4.8V (STD. 参考值)								
		≤0.11sec/60° at 6.0V (STD. 标准值)								
5	Rated Torque 额定扭矩	≥0.33kgf·cm at 4.8V (STD. 参考值)								
		≥0.37kgf·cm at 6.0V (STD. 标准值)								
6	Stall Current 堵转电流	≤700mA at 4.8V (STD. 参考值)								
		≤800mA at 6.0V (STD. 标准值)								
7	Stall Torque* 堵转扭矩	≥1.3kgf·cm at 4.8V (STD. 参考值)	扭力磅测试							
		≥1.5kgf·cm at 6.0V (STD. 标准值)								
8	Rotating Direction* 旋转方向	CCW (1000→2000 μs) 逆时针	俯视输出轴端方向							
9	Pulse Width Range 信号宽度范围	500~2500 μs								
10	Neutral Position 中位	1500 μs								
11	Operating Travel Angle 操作角度	90° ±10° (1000~2000 μs)								
12	Mechanical Limit Angle 机械极限角度	210°								
13	Angle deviation 角度精度	≤ 1°	即回中差							
14	L&R Angle deviation 左右两边角度精	≤ 5°	即边角差							
15	Back Lash* 虚位	≤ 1°								
16	Dead Band Width 死区宽度	≤ 3 μs	最小启动信号宽度							
17	Operating Temperature Range 工作环境	-10℃~+50℃; ≤90%RH								
18	Storage Temperature Range 储存温度	-20℃~+60℃; ≤90%RH								
19	Weight 重量	13.5 ± 0.5g								
20	Case Material 外壳材质	ABS								
21	Gear Set Material 齿轮材质	Metal gear 金属齿轮								
22	Motor Type 马达类型	Coreless motor 空心杯马达								
23	Angle Sensor 角度传感器	Type 类型	Carbon Film Potentiometer 碳膜电位器							
		Angle 角度	210							
		Life 寿命	500,000 Cycles (Min.)							
24	Connector and Cable 连接器和电缆	Type 类型	JR							
		Material 材质	PVC							
		Length 线长度	245 ± 5mm (外露不含插头)							
		Pin Assignment 引脚定义	<table border="1" style="width: 100%; border-collapse: collapse;"> <tr> <td style="width: 20px;">1</td> <td style="width: 50px;">Brown 棕</td> <td style="width: 50px;">GND</td> </tr> <tr> <td>2</td> <td>Red 红</td> <td>Vcc</td> </tr> <tr> <td>3</td> <td>Orange 橙</td> <td>Signal / PWM</td> </tr> </table>	1	Brown 棕	GND	2	Red 红	Vcc	3
1	Brown 棕	GND								
2	Red 红	Vcc								
3	Orange 橙	Signal / PWM								



Outside Dimension外观尺寸:(Unit单位: mm)

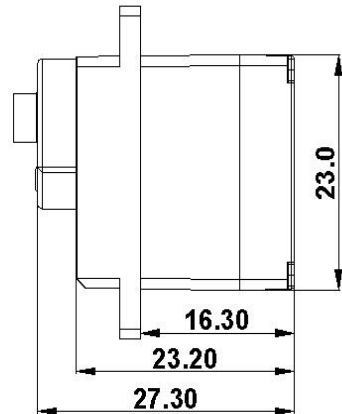
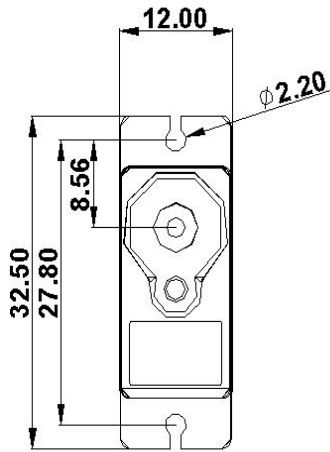

Accessories配件:



Electrical Schematic Diagram 电路简图:

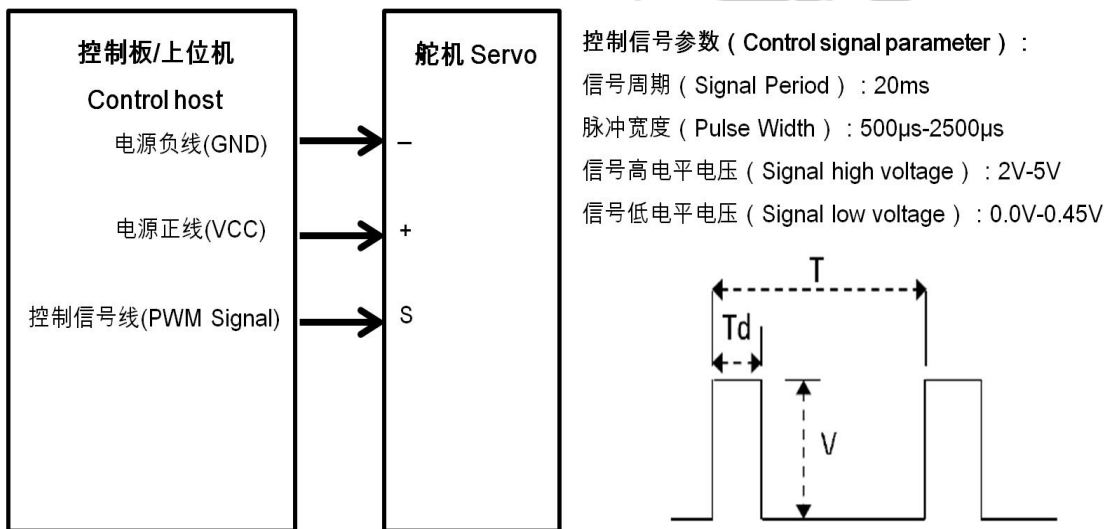

Remarks 备注:

* Initial Performance Data By DS Servo Tester At 23±5°C.

* 起始性能数据是在23±5°C下通过德晟标准舵机测试架测试的数据。”

(Sample Plan抽样计划:

Appearance 外观: MIL-STD-105E AQL II (MA=0.65/MI=1.0)

Dimension and Function 尺寸及功能: MIL-STD-105E AQL I (MA=0.65/MI=1.0))