

ZMOD4410

Gas Sensor Module for TVOC and Indoor Air Quality

Description

The [ZMOD4410](#) Gas Sensor Module is designed for easy implementation to detect total volatile organic compounds (TVOC), estimate CO₂, and monitor indoor air quality (IAQ). The module works reliably in various conditions, including very humid and dusty applications with the possibility of water spray, condensation, or immersion. The small LGA assembly consists of a gas sense element and a CMOS signal conditioning IC. The sense element is a Si-based microhotplate with a robust and highly sensitive metal oxide (MOx) chemiresistor. The signal conditioner (ASIC) controls the sensor temperatures and measures the MOx conductivity, which is a function of the gas concentration. The measurement results are easily read via an I2C interface with the user's microprocessor, which processes the data.

The firmware configurable platform quickly enables different ZMOD4410 features based on machine learning algorithms and embedded artificial intelligence (AI) with Renesas pre-trained models and algorithms. This is used to determine and output TVOC concentration, IAQ rating according to UBA, and estimated carbon dioxide (eCO₂) level. Alternate algorithms and firmware implementations can output an absolute TVOC concentration to meet Public Building Air Quality (PBAQ) standards; a relative IAQ rating based on total VOC and odor levels changes or discriminate between sulfur-based odors. With the ultra-low operating current consumption implementation, the ZMOD4410 is an excellent choice for low-voltage and ultra-low power battery applications.

Typical Applications

- Indoor air monitoring to meet UBA and typical Public Building Air Quality (PBAQ) standards
- Monitor home, office, personal, and bathroom environments for healthy conditions and comfort
- Detect hazardous materials and unhealthy conditions (e.g., fumes from construction materials)
- Automation based on indoor ambient air quality (HVAC, air purifiers, thermostats, kitchen hoods, etc.)

Features

- Sensor output based on AI machine learning algorithmic:
 - Absolute measurement of total organic compounds (TVOC) concentrations and indoor air quality (IAQ) to meet UBA air quality standard
 - Estimated carbon dioxide level (eCO₂)
 - Absolute TVOC output to meet Public Building Air Quality (PBAQ) standards
 - Relative IAQ based on TVOC and odor changes
 - Algorithm to discriminate sulfur-based odors
- High sensitivity to Hydrogen (H₂) based on resistance output
- Heater driver and regulation loop for constant resistance, minimizing effect of environmental temperature on signal
- Built-in nonvolatile memory (NVM) for module-specific data (configuration and calibration)
- Ultra-low average power consumption down to 160μW
- Excellent for low-voltage and ultra-low power battery applications
- No external trimming components required
- External reset pin (active-LOW)
- Siloxane resistant
- JEDEC JESD47 qualified for 10 years lifetime
- Supply voltage: 1.7V to 3.6V
- Package: 12-LGA
- RoHS compliant
- Water and dustproof version available (IP67 certified)
- Available assembly sizes:
 - 3.0 × 3.0 × 0.7 mm (standard version)
 - 3.0 × 3.0 × 0.9 mm (for IP67 version)

Available Support

- Evaluation Kits for USB and Pmod™ board
- Manuals, application notes, blog, and white papers
- Instructional videos
- Example codes, API, pre-compiled libraries, and algorithm support to optimize performance
- Third-party certification for compliance with accepted international IAQ standards and best available technology for eCO₂

Contents

1. Overview	4
1.1 Block Diagram	4
1.2 Application Circuit	4
2. Pin Information	5
2.1 Pin Assignments	5
2.2 Pin Descriptions	5
3. Specifications	6
3.1 Absolute Maximum Ratings	6
3.2 Electrical Characteristics	7
4. Sensor Module Characteristics	8
4.1 Gas Sensor Module	8
5. Gas Sensor Module Operation Modes and Characteristics	9
5.1 IAQ 2 nd Generation (Absolute Measurement)	10
5.1.1 Air Quality – IAQ Levels According to UBA	10
5.1.2 Air Quality – Estimated Carbon Dioxide Correlation (eCO ₂)	11
5.1.3 Accuracy and Consistency	12
5.2 Public Building Air Quality Standards (Absolute Measurement)	13
5.3 Relative IAQ	14
5.4 Sulfur-based Odor Discrimination	15
5.5 Conditioning, Sensor Self-Check Status, and Stability	15
5.6 Environmental Influences	16
5.7 Sensor Module Algorithm and Firmware	16
6. Assembly Restrictions, Operation, Integration Notes, and Storage	17
7. Test and Calibration	18
8. I2C Interface and Data Transmission Protocol	18
9. Related Websites and Software	20
10. Glossary	20
11. Package Outline Drawings	21
12. Marking Diagram	21
13. Ordering Information	22
14. Revision History	23

Figures

Figure 1. Block Diagram	4
Figure 2. Application Circuit.....	4
Figure 3. Pin Assignments for 12-LGA Module – Top View	5
Figure 4. Typical ZMOD4410 Response to Levels of TVOC Described by UBA Using EPA Std. Mixture	11
Figure 5. Typical Graph of CO ₂ Correlation.....	11
Figure 6. IAQ Accuracy and Consistency.....	12
Figure 7. Concentration Dependent Accuracy for eCO ₂	12
Figure 8. TVOC Measurement According to Typical PBAQ Standards using ZMOD4410.....	13
Figure 9. Scale of the Relative IAQ	14
Figure 10. Comparison of IAQ 2 nd Gen and Relative IAQ.....	14
Figure 11. ZMOD4410 Typical Response Time and Signal Stability for TVOC Exposure.....	15
Figure 12. Humidity Influence at Three Different TVOC Concentrations	16
Figure 13. Typical Solder Profile.....	17
Figure 14. I2C Data Transmission Protocol.....	19
Figure 15. Bus Timing.....	19

Tables

Table 1. Pin Descriptions.....	5
Table 2. Absolute Maximum Ratings.....	6
Table 3. Electrical Characteristics	7
Table 4. Gas Sensor Module Specifications during Operation.....	8
Table 5. Sample Rates and Warm-Up Samples for ZMOD4410 Operation Modes.....	9
Table 6. Level of Indoor Air Quality Based on TVOC Levels Described by UBA.....	10
Table 7. Typical ZMOD4410 Sensor Module Performances.....	12
Table 8. Typical Sensor Requirement to Meet a PBAQ Standard	13
Table 9. Final Test Parameters	18
Table 10. Bus Timing Characteristic.....	19
Table 11. Package Options	21

1. Overview

1.1 Block Diagram

Note: For definitions of abbreviations, see "Glossary."

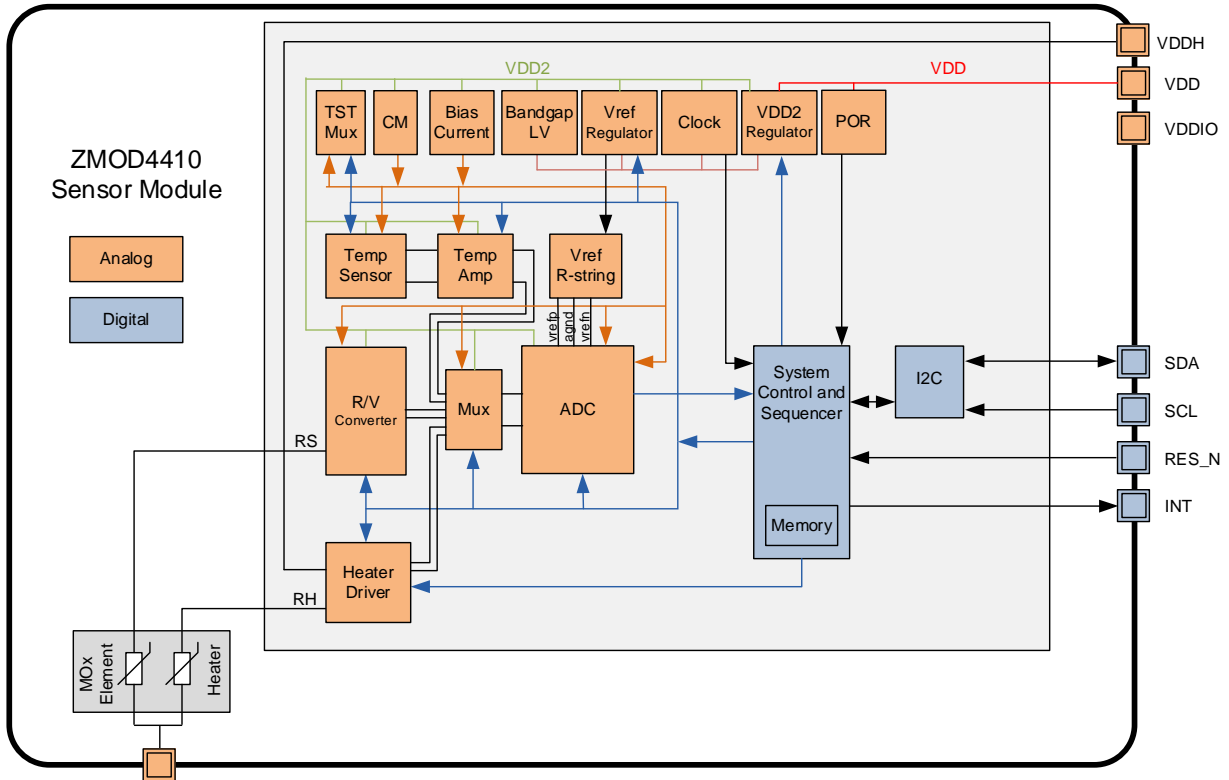

Figure 1. Block Diagram

1.2 Application Circuit

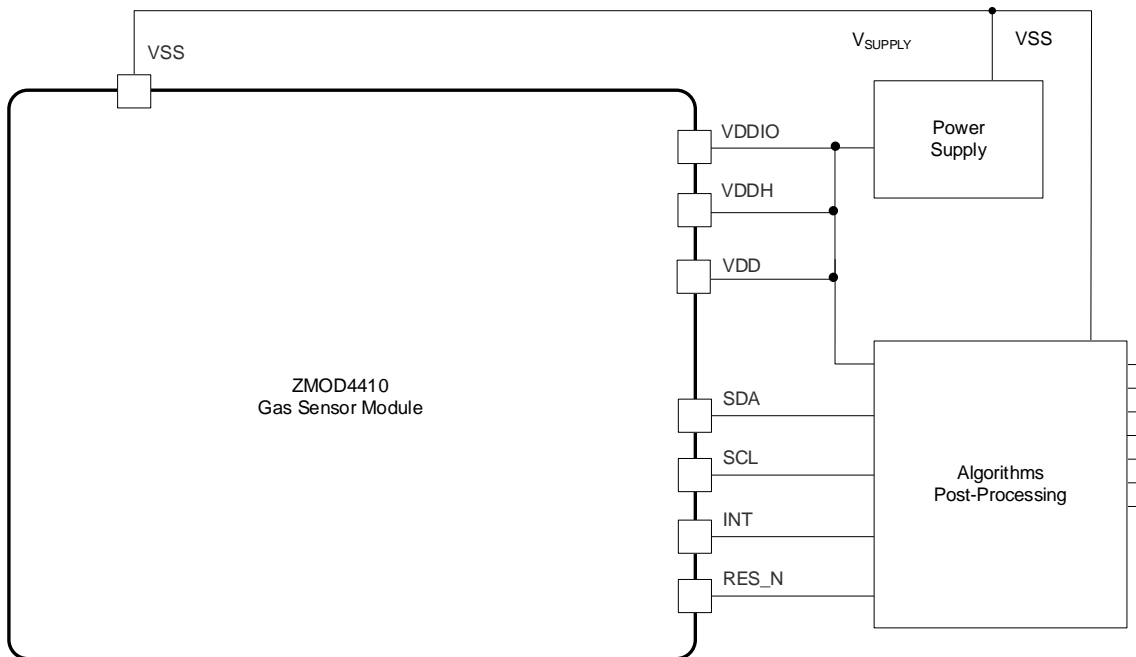

Figure 2. Application Circuit

2. Pin Information

2.1 Pin Assignments

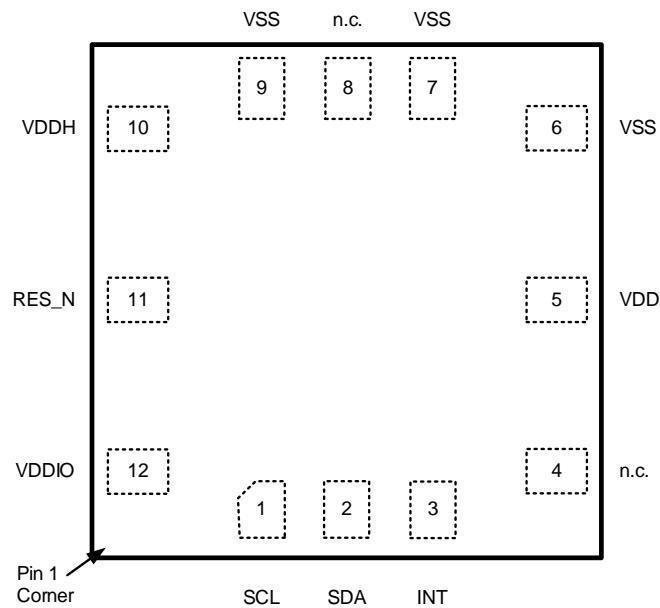

Figure 3. Pin Assignments for 12-LGA Module – Top View

2.2 Pin Descriptions

Table 1. Pin Descriptions

Pin Number	Name	Type	Description
1	SCL	Input	Serial clock for the I2C interface.
2	SDA	Input/Output	Serial data for the I2C interface. Default 7-bit slave address: 32 _{HEX} .
3	INT	Output	Interrupt signal (push-pull): <ul style="list-style-type: none"> ▪ HIGH when a measurement is running ▪ LOW when a measurement has finished <i>Note:</i> Use edge detection on falling edge!
4	n.c.	-	Do not connect.
5	VDD	Supply	Voltage supply for the ZMOD4410.
6	VSS	Ground	Ground reference for the ZMOD4410.
7	VSS	Ground	Ground reference for the ZMOD4410.
8	n.c.	-	Do not connect.
9	VSS	Ground	Ground reference for the ZMOD4410.
10	VDDH	Supply	Voltage supply for the integrated heater in the ZMOD4410.
11	RES_N	Input	ZMOD4410 reset; active low.
12	VDDIO	Supply	Voltage supply for I/O-interface in ZMOD4410.

3. Specifications

3.1 Absolute Maximum Ratings

The absolute maximum ratings are stress ratings only. The ZMOD4410 may not be operable above or below the recommended operating conditions in Table 2. Stresses exceeding the absolute maximum ratings will change the sensor module accuracy, lead to imprecision, and eventually cause irreversible damage to the device. In addition, extended exposure to stresses above the recommended operating conditions may affect device reliability. Renesas does not recommend designing to the “Absolute Maximum Ratings”.

Note: The reference for all voltages is V_{SS} .

Table 2. Absolute Maximum Ratings

Symbol	Parameter	Minimum	Maximum	Unit
V_{DD}	Supply Voltage	1.7	3.6	V
V_{DD} , V_{DDH} , V_{DDIO}	Maximum Analog and I/O Supply Voltage	-0.4	3.63	V
V_{A_IO} , V_{D_IO}	Maximum Voltage at all Analog and Digital I/O Pins	-0.5	$V_{DDIO} + 0.5$	V
	Maximum Difference in Voltage between VDD and VDDH Pins	-	0.4	V
I_{IN}	Input Current into any Pin Except Supply Pins (Latch-Up Immunity)	-100	100	mA
V_{HBM1}	Electrostatic Discharge Tolerance – Human Body Model (HBM)	-	2000	V
V_{CDM}	Electrostatic Discharge Tolerance – Charged Device Model (CDM) on Packaged Module	-	750	V
$T_{AMB-MAX}$	Maximum Ambient Temperature Range of Sensor Module	-40	125	°C
T_{STOR}	Storage Temperature	-50	125	°C
$T_{OPERATION}$	Operation Temperature of Sensing Element ^[1]	-	550	°C

1. Controlled via API in firmware and EVK software.

3.2 Electrical Characteristics

Values below are valid at operating conditions unless noted otherwise.

Table 3. Electrical Characteristics

Symbol	Parameter	Conditions	Minimum	Typical	Maximum	Unit
	Average Power: IAQ 2 nd Gen, Relative IAQ and Sulfur-based Odor Discrimination		-	6	-	mW
	Average Power: IAQ 2 nd Gen ULP and Relative IAQ ULP	Ultra-Low Power operation	-	0.16	-	mW
	Average Power: PBAQ		-	1	-	mW
I _{ACTIVE}	Supply Current, Active Mode including Heater Current for IAQ 2 nd Gen, Relative IAQ, Ultra-low Power and Sulfur-based Odor Discrimination	At VDD = 1.8 V	-	7.4	16.2	mA
		At VDD = 3.3V	-	5.2	10.3	mA
I _{ACTIVE}	Supply Current, Active Mode including Heater Current for PBAQ	At VDD = 1.8 V	-	9.9	16.4	mA
		At VDD = 3.3V	-	6.9	10.6	mA
I _{SLEEP}	Current during measurement delays	Sleep Mode ASIC	-	450	-	nA
PSRR	Power Supply Rejection Ratio	V _{DD} ≥ 2.0V	-	30	-	dB
	Timing Accuracy (Valid for Measurements Only) (Sleep Timer is ±20%)	At room temperature; for timings derived from the internal clock.	-2	-	2	%
		Over-temperature range; for timings derived from the internal clock.	-0.1	-	0.1	%/K
r _{ADC}	ADC Resolution		10	-	16	Bit
t _{STA1}	Start-up Time: V _{DD} Ramp up to Interface Communication		-	-	1	ms
f _{C,I2C}	I2C Clock Frequency		-	-	400	kHz
t _{VPP}	NVM Programming Time		-	6	16	ms
t _{RET_FTP}	Data Retention	85°C junction temperature	10	-	-	years
	NVM Programming Cycles		1000	-	-	cycles
	Default I2C Communication Address	7-bit slave address	-	32 _{HEX}	-	-
	Blocking Capacitor for Power Supply	Ceramic type; recommended to be placed close to gas sensor module	100	-	-	nF
VIH	Logic Voltage Level High	Applies for RES_N, SCL, and SDA	0.7* V _{DDIO}	-	-	
VIL	Logic Voltage Level Low	Applies for RES_N, SCL, and SDA	-	-	0.3* V _{DDIO}	

4. Sensor Module Characteristics

4.1 Gas Sensor Module

The ZMOD4410 Gas Sensor Module is designed to detect typical TVOC contaminations based on studies and international standards for indoor air quality. In parallel to TVOC detection, it also responds excellent, but not selectively, to Hydrogen (H₂) in the full parts-per-million range. Characteristic module parameters are shown in Table 4. The response time for a gas stimulation is always within a few seconds, depending on the specific gas molecule and its concentration. An active or direct airflow onto the sensor module is not necessary because diffusion of ambient gas does not limit the sensor module's response time.

Important: The ZMOD4410 also can detect safety-relevant gases for indoor air, such as carbon monoxide (CO); however, the sensor module is not designed to detect these interferants reliably and therefore it is not approved for use in any safety-critical or life-protecting applications. It must not be used in such applications, and Renesas disclaims all liability for any such use.

Table 4. Gas Sensor Module Specifications during Operation

Symbol	Parameter	Conditions	Minimum	Typical	Maximum	Unit ^[1]
	Raw Resistance Measurement Range	Ethanol or Hydrogen in air	0		1000	ppm
			0		1000000	ppb ^[2]
	IAQ and TVOC specified Measurement Range to meet UBA ^[3]	Ethanol in air	160		10000	ppb
	TVOC specified Measurement Range for PBAQ	Ethanol in air	1		2000	µg/m ³
RH _{AMB}	Humidity Range for Sensor Module Operation	All ZMOD operations except PBAQ operation, Non-condensing	0		90	% RH
		Specification to meet PBAQ, Non-condensing		50		% RH
T _{AMB}	Temperature Range for Sensor Module Operation	All operation modes except PBAQ, Non-condensing	-40		65	°C
		Specification according to PBAQ, Non-condensing		21		°C
S	Sensitivity over Lifetime	Resistance in Clean Air / Resistance at 10ppm Ethanol (R _{Air} /R _{Gas})		5		Ω/Ω
T-80	Sensor Module Response Time ^[4]	Samples needed to change to 80% of end value (all operation modes except ULP)		15		Samples

1. The abbreviation ppm stands for "parts per million," and ppb stands for "parts per billion" (e.g., 1ppm equals 1000ppb).
2. Conversion from ppm to mg/m³ for most common TVOC is by the factor approximately 2 (e.g., 1ppm equals approximately 2mg/m³).
3. Source: Umweltbundesamt, Beurteilung von Innenraumluftkontaminationen mittels Referenz- und Richtwerten, (Bundesgesundheitsblatt – Gesundheitsforschung – Gesundheitsschutz, 2007).
4. Response times depend on TVOC gas and concentration.

5. Gas Sensor Module Operation Modes and Characteristics

The ZMOD architecture leverages different “Methods of Operation” (Operation Modes), which use time, temperature, and signatures from gases that enable unique signals from a highly trained machine learning system and makes use of embedded artificial intelligence (AI) technology. This section discusses the different operation modes of the ZMOD4410. The following operation modes are released:

Family of software releases:

- IAQ 2nd Gen: IAQ, TVOC, eCO₂ (recommended for new designs)
- IAQ 2nd Gen ULP: IAQ, TVOC, eCO₂ (Ultra-Low Power)
- Public Building Air Quality – TVOC measurement to meet Public Building Air Quality (PBAQ) standards
- Relative IAQ
- Relative IAQ Ultra-Low Power
- Sulfur-based Odor Discrimination
- IAQ 1st Generation – Legacy (not recommended for new designs)
- IAQ 1st Generation Low Power – Legacy (not recommended for new designs)
- Odor – Legacy (not recommended for new designs)

By default, the IAQ 2nd Generation operation should be used for new designs due to absolute gas concentration readings, better consistency and accuracy compared to traditional gas sensor module algorithms. Table 5 provides an overview of recommended ZMOD4410 operation modes including their sample rate and the warm-up (stabilization) samples after each power on. The warm-up times are fixed and algorithm results should be taken into account only after the warm-up.

Table 5. Sample Rates and Warm-Up Samples for ZMOD4410 Operation Modes

Operation Mode	Sample Rate [Seconds]	Warm-Up Samples Upon Start
IAQ 2 nd Gen (recommended for new IAQ designs)	3	100
IAQ 2 nd Gen Ultra-Low Power (recommended for IAQ designs requiring ULP)	90	10
Public Building Air Quality	5	60
Relative IAQ	3	100
Relative IAQ Ultra-Low Power	90	10
Sulfur-based Odor Discrimination	3	60

In addition, details for sensitivity, reliability, sample rates, and sensor module influences are explained in detail in the following sections. All graphs and information show the typical responses that are to be expected from the sensor module upon exposure to a variety of test conditions. Additional technical information on sensitivity, selectivity, and stability for all operation modes is available in Renesas’ *ZMOD4410 Application Note – TVOC Sensing*. For more information, including application notes, white papers, blog, and manuals, visit the [ZMOD4410](#) product page.

5.1 IAQ 2nd Generation (Absolute Measurement)

These operation modes are used for absolute measurements of indoor air quality (IAQ) according to UBA with eCO₂.

The following sections provide information on TVOC gases, concentrations, and thresholds given by the German Federal Environmental Agency (UBA)¹ and the US Environmental Protection Agency (EPA). These standards provide reliable information on indoor air quality and recommendations for air improvements if necessary.

5.1.1. Air Quality – IAQ Levels According to UBA

The algorithm provided by Renesas for the user’s microprocessor uses the output from the ZMOD4410 to determine the level of TVOC gases present (see *ZMOD4410 Programming Manual – Read Me*; see also section 5.7). The algorithm features an automated baseline correction function, ensuring that the module can learn from its environment and distinguish elevated levels of TVOC under all conditions. The proprietary metal oxide (MOx) used in the sensor module allows it to respond effectively to changing TVOC levels during long-term operation.

Renesas has adopted the definition of TVOCs and their impact on user health and comfort proposed by the UBA (see Table 6). The ZMOD4410 can detect the presence of elevated TVOC levels as described in the UBA study.¹

There are many sources of poor indoor air quality that can elevate TVOC levels in the typical home or office environments, and the types of TVOC that might be present can vary widely. Additional information on this topic is available in Renesas’ *ZMOD4410 White Paper – Overview of TVOC and Indoor Air Quality*.

The ZMOD4410 can respond reliably to all types of organic compounds that are typically found in indoor environments. To assess the response of the gas sensor module to the levels described in the UBA study, the module has been tested using several TO-15/17 multi-component TVOC standards defined by the EPA. The ZMOD4410 response to the EPA standard with the TVOC levels from UBA is shown in Figure 4. A third-party report and certification from an independent research lab are available on the Renesas website that confirms the good conformity for IAQ measurements with respect to the UBA study and EPA standard.

Table 6. Level of Indoor Air Quality Based on TVOC Levels Described by UBA

Renesas IAQ Rating	Reference Level [1]	Air Information	TVOC (mg/m ³) [1]	Air Quality
≤ 1.9	Level 1	Clean Hygienic Air (target value)	< 0.3	Very Good
2.0 to 2.9	Level 2	Good Air Quality (if no threshold value is exceeded)	0.3 to 1.0	Good
3.0 to 3.9	Level 3	Noticeable Comfort Concerns (not recommended for exposure > 12 months)	1.0 to 3.0	Medium
4.0 to 4.9	Level 4	Significant Comfort Issues (not recommended for exposure > 1 month)	3.0 to 10.0	Poor
≥ 5.0	Level 5	Unacceptable Conditions (not recommended)	> 10.0	Bad

1. Conversion from mg/m³ to ppm for many common TVOC is by the factor approximately 0.5 (e.g., 10mg/m³ equals approximately 5ppm). Conversion from ppm to ppb is by the factor 1000 (e.g., 0.1ppm equals 100ppb).

¹ Umweltbundesamt, *Beurteilung von Innenraumluftkontaminationen mittels Referenz- und Richtwerten*, (Bundesgesundheitsblatt - Gesundheitsforschung - Gesundheitsschutz, 2007).

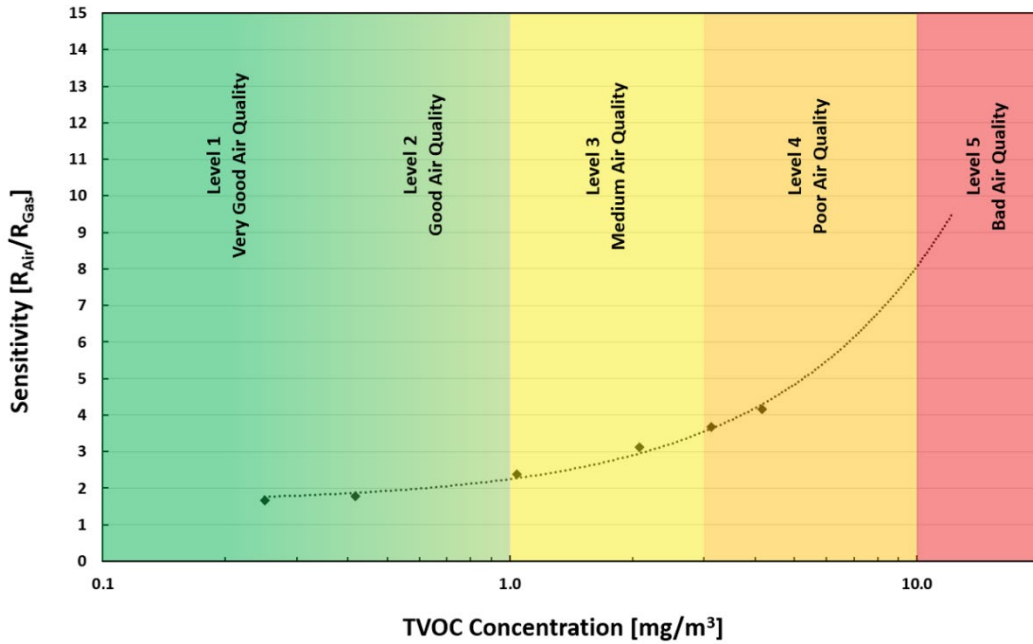

Figure 4. Typical ZMOD4410 Response to Levels of TVOC Described by UBA Using EPA Std. Mixture

Note: TVOC is a subset comprising 25 of the EPA’s TO-15/17 certified mixtures.

5.1.2. Air Quality – Estimated Carbon Dioxide Correlation (eCO₂)

A very reliable correlation can be made based on TVOC levels for situations where an elevated carbon dioxide (CO₂) concentration is caused by human occupancy, although the sensor module is not directly responsive to CO₂. Renesas has developed a robust, patent pending, correlation between elevated TVOCs and CO₂ attributable to human occupancy in a wide variety of living spaces, including homes and offices. The measurement range for the eCO₂ has its minimum at the atmospheric background level at 400ppm and ranges up to 5000ppm. The correlation can predict the CO₂ level as shown in Figure 5. Additional details about Renesas’ CO₂ correlation are available in the *ZMOD4410 Application Note – Estimating Carbon Dioxide*.

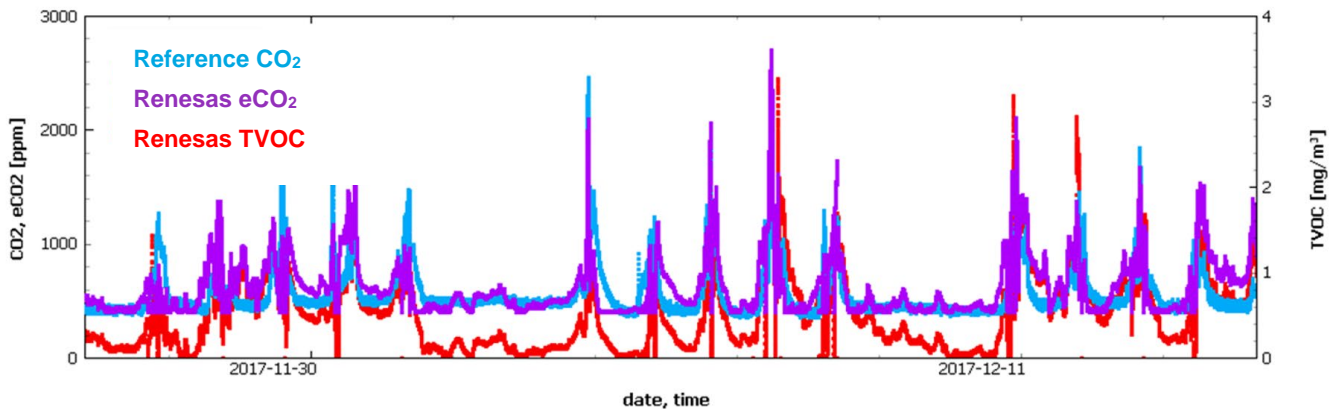

Figure 5. Typical Graph of CO₂ Correlation

5.1.3. Accuracy and Consistency

All Renesas gas sensor modules come with electrical and chemical factory calibration with data stored in the module’s nonvolatile memory (NVM). Using the algorithms provided by Renesas and the calibration coefficients in the NVM will lead to stable measurement of the IAQ levels according to UBA discussed in section 5.1.1 with a maximum deviation of ±1 category over the module’s lifetime. Typical IAQ accuracy and consistency in an appropriate system implementation are displayed in Table 7 and in Figure 6. The accuracy for Renesas eCO2 algorithm was proved on more than 20000 measurements and is shown in Figure 7.

Table 7. Typical ZMOD4410 Sensor Module Performances

Parameter	Conditions	Minimum	Typical	Maximum	Unit
Accuracy for IAQ	Full UBA range ^[1]		± 1		IAQ
Accuracy for IAQ Ultra-Low Power	Full UBA range ^[2]		± 1		IAQ
Consistency for IAQ	Part-to-Part Variation ^[3]		± 10		%

1. With a 95% confidence based on more than 26500 measurements with 280 sensor modules.
2. With 82% confidence based on more than 3500 measurements with 104 sensor modules.
3. Based on more than 30000 measurements with 380 sensor modules.

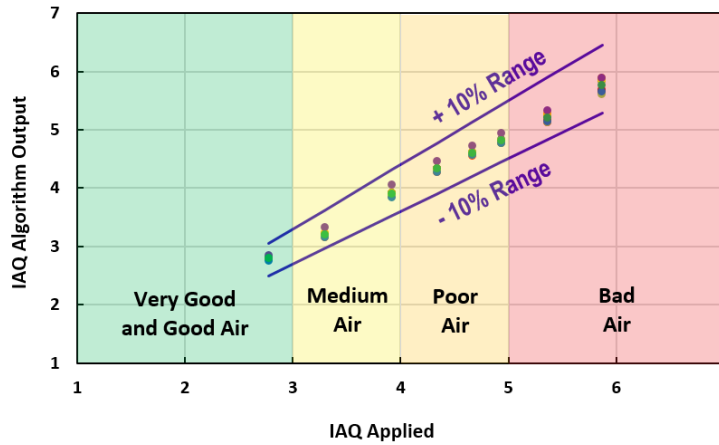

Figure 6. IAQ Accuracy and Consistency

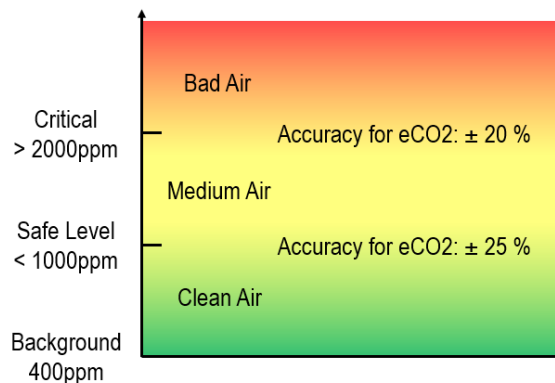

Figure 7. Concentration Dependent Accuracy for eCO2

5.2 Public Building Air Quality Standards (Absolute Measurement)

This operation mode is used for absolute measurements of TVOC to meet Public Building Air Quality (PBAQ) standards released globally [2][3]. PBAQ standards promote health, cognitive scores, and well-being in buildings. Several aspects of environmental parameters are evaluated, including TVOC. To meet a PBAQ standard a TVOC sensor must fulfill a specification as typically seen in Table 8.

Table 8. Typical Sensor Requirement to Meet a PBAQ Standard

Parameter	Unit	Typical Range	Typical Accuracy	Resolution	Calibration Gas
TVOC	ppb or $\mu\text{g}/\text{m}^3$	1 to 2000 $\mu\text{g}/\text{m}^3$	$\pm 20 \mu\text{g}/\text{m}^3 + 15\%$ at 1 to 500 $\mu\text{g}/\text{m}^3$	1 $\mu\text{g}/\text{m}^3$	Ethanol

TVOC sensors must have very high resolution in the low $\mu\text{g}/\text{m}^3$ (ppb) concentration range, which is fulfilled using the Renesas ZMOD4410 gas sensor module with the PBAQ algorithm firmware. A comparison with a reference is shown in Figure 8.

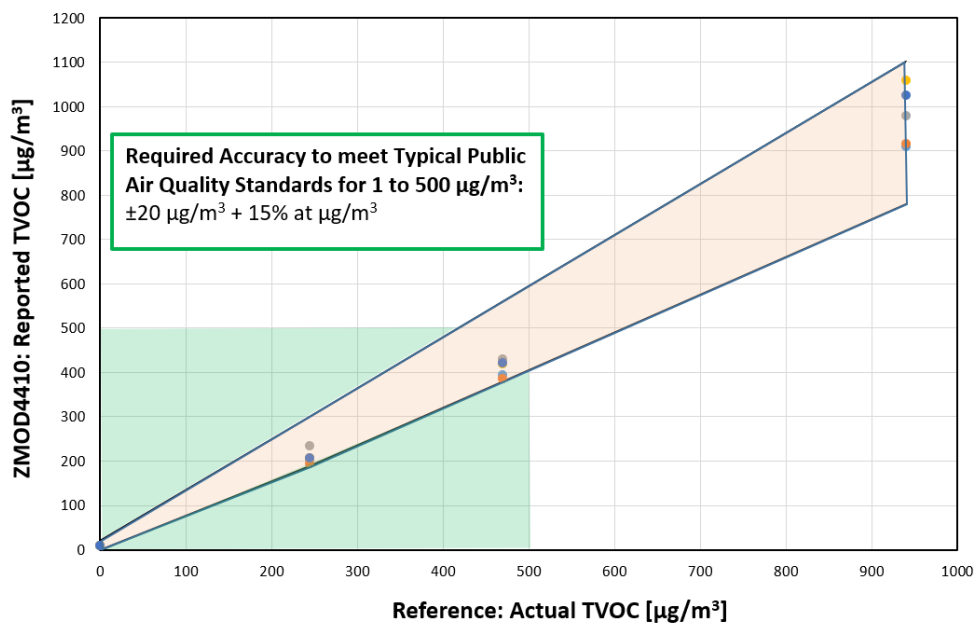

Figure 8. TVOC Measurement According to Typical PBAQ Standards using ZMOD4410

The downloadable firmware and evaluation kit software for the ZMOD4410 allows it to meet different Public Building Air Quality standards; however, it should be highlighted that PBAQ standards usually require calibration of the final product itself. In addition, all sensors measuring air quality parameters need to be recalibrated or replaced annually.

² IWBI, WELL Performance Verification Guidebook (International WELL Building Institute PBC), 2022. For more information about the WELL standard, see [WELL](#); for information about the WELL specification, see [specification](#).

³ Regenerative Ecological, Social, and Economic Targets (RESET), Air Standards for Accredited Monitors v2.0, 2018. For more information about the RESET standard, see [RESET](#); for information about the RESET specification, see [specification](#).

5.3 Relative IAQ

Renesas provides firmware and algorithms, which allow the ZMOD4410 to learn its environment. In this operation mode, the gas sensor module will only respond to changes in the ambient conditions by detecting changes in the relative ambient TVOC concentration.

Advantages of this operation mode are an easy establishment of threshold limits to trigger actions (e.g., turn on a fan for ventilation) in which case no absolute TVOC concentration readings are needed and an even smaller memory footprint in the user’s microprocessor. Also, this operation mode is similar to the human nose, in which small concentration changes are rapidly detected with high sensitivity while very slow changes are suppressed. The sensor will react immediately to all TVOC, but the algorithm uses a time constant of 24 hours for a full decay. In the case where no change in air quality takes place within this time, the algorithm will converge to an index of 100. This scale index is defined in the style of the EPA scale for Outdoor Air Quality⁴ as the following (see Figure 9):

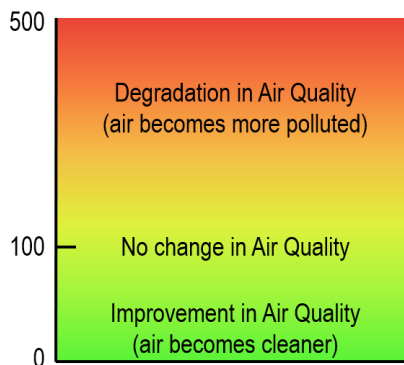

Figure 9. Scale of the Relative IAQ

Figure 10 provides a comparison of the IAQ 2nd Generation algorithm (see section 5.1) and the Relative IAQ algorithm for a week of data collection in an indoor environment. Events such as opening a window during day and nighttime and trends for TVOC are clearly seen – while the Relative IAQ looks smoother – react more sensitive on TVOC changes and start adapting (decreasing) at high TVOC exposures over time.

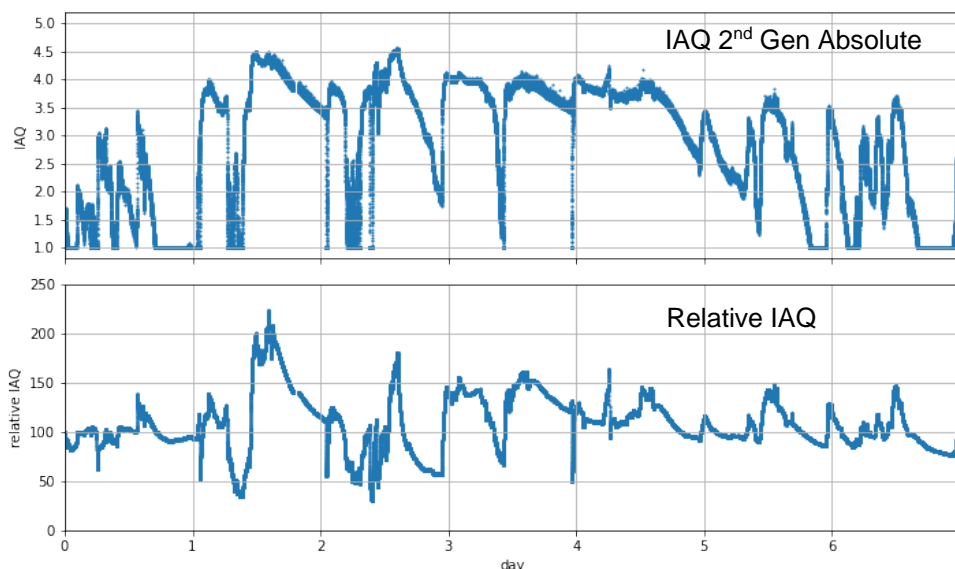

Figure 10. Comparison of IAQ 2nd Gen and Relative IAQ

1. For more information on Outdoor Air Quality and how to detect it, see the [ZMOD4510](#) product page.

5.4 Sulfur-based Odor Discrimination

This operation mode can be used to identify if a sulfur-smelling odor is present. When the target gas families have been defined through analysis, a sweeping method allows for chemical discrimination. A machine learning embedded artificial intelligence (AI) algorithm makes use of a MOx surface temperature array to get to a selectivity approach.

This operation mode classifies the odors in “sulfur” (sulfur-based) and “acceptable” (organic based) and shows an intensity level of the smell. Acceptable odors are, for example, coming from air refreshers, soaps, perfumes etc., while bad smelling sulfur-based odors come from personal odors in bathrooms. Because impression of smell is very unique, there might be overlaps with how people perceive odors. To bring this in an algorithm, a highly trained Neural Network is using typical chemical signatures from Hydrogen sulfide (H₂S) and Dimethyl sulfide (DMS, C₂H₆S). A range of organic sulfur compounds are considered from the low ppb to the ppm range. The typical sample rate is 3 seconds, but the algorithm may need a few samples for the correct classification.

This sulfur-based odor discrimination firmware was developed based on known commercially available products that represent both bad and acceptable odors. Other places with unknown chemical signatures can lead to incorrect algorithm results. Training the sensor module and developing the discrimination for other gases and applications may be considered for future releases.

5.5 Conditioning, Sensor Self-Check Status, and Stability

The ZMOD4410 will respond to TVOC immediately upon start-up; however, a conditioning period of at least 48 hours of continuous operation in an ambient environment is recommended to improve stability and obtain maximum performance.

The sensor module has a self-check for its general functionality. With every measurement the algorithm performs an internal check of resistances to identify potential damage (e.g., broken heater or membrane structures), and the ZMOD4410 measurement output contains a sensor self-check status with either warm-up, valid, or damage.

Figure 11 shows the ZMOD4410 sensor module’s raw data response to clean air with 30%RH and its response to 5ppm, 10ppm, and 20ppm ethanol mixed in clean air. The result is a very stable, fast changing, and repeatable sensor module signal with a high sensitivity.

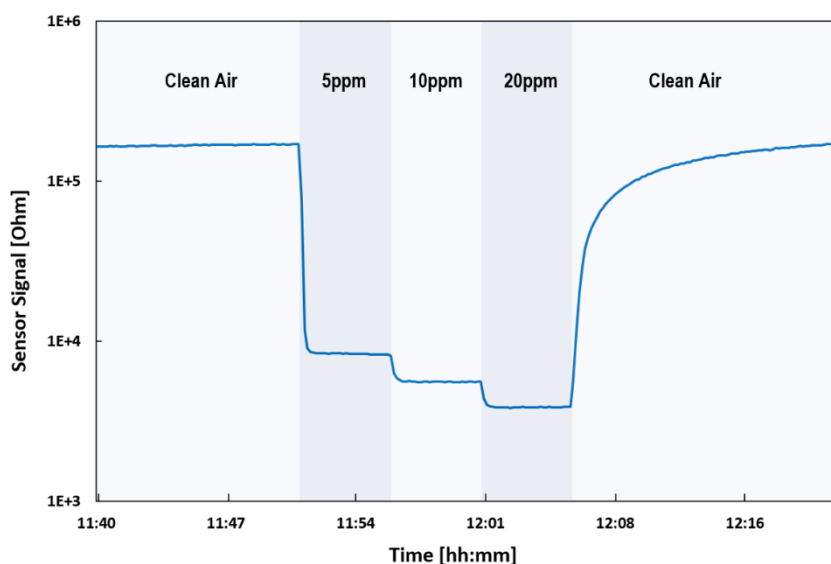

Figure 11. ZMOD4410 Typical Response Time and Signal Stability for TVOC Exposure

5.6 Environmental Influences

Although the ZMOD4410 sensor module is tested, qualified, and functional in the range of -40°C to +65°C, the best performance according to its calibration is achieved in the temperature range of 0°C to +40°C. Figure 12 shows the module's response to variations in the range from 15% to 65% relative humidity for ethanol concentrations mentioned in section 5.4.

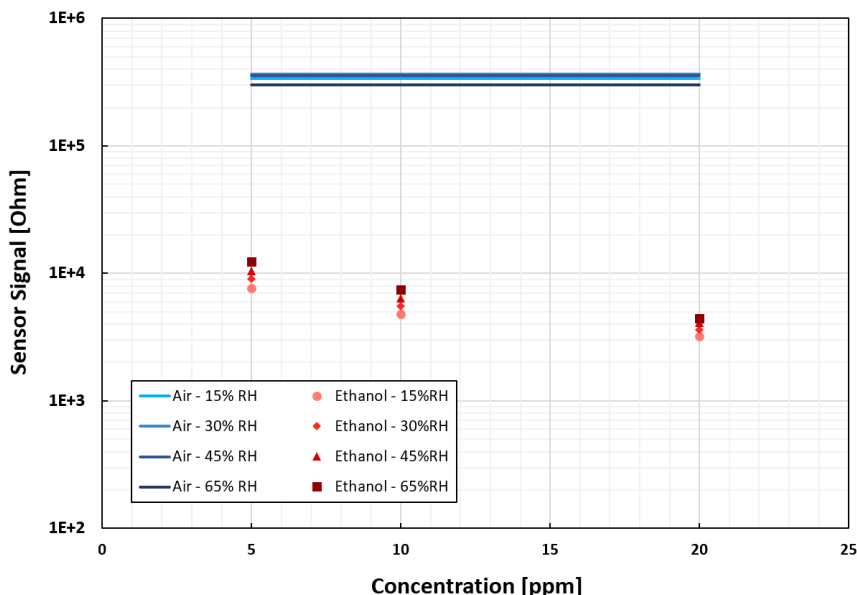

Figure 12. Humidity Influence at Three Different TVOC Concentrations

For IAQ 2nd Gen and IAQ 2nd Gen ULP, temperature or relative humidity compensation are not required but are recommended for best performance. If relative humidity and temperature values are provided to the algorithm, the ZMOD4410 automatically uses these values for compensation. If no temperature or humidity data are provided, these parameters are recommended to be set to 23°C and 30% RH for standard indoor applications.

For some environments, an interference response to siloxanes is of concern; however, the ZMOD4410 has proven to be resistant against siloxanes. A maximum potential lifetime exposure has been simulated in all ZMOD4410 operation modes by applying the chemicals D4 (octamethylcyclotetrasiloxane) and D5 (decamethylcyclopentasiloxane) in high concentration for several hundred hours. For more information on test conditions and results, see *ZMOD4410 Application Note – TVOC Sensing*.

5.7 Sensor Module Algorithm and Firmware

To operate the ZMOD4410, the software and libraries provided by Renesas should be used. The algorithm for the user's microprocessor always uses the raw output signals from the ZMOD4410, which are resistances, to determine the level of gases present. Depending on the microprocessor and compiler used, the firmware and its algorithms require 10 to 30 kB flash size. All algorithms feature an automated baseline correction function, ensuring that the module can learn from its environment and distinguish elevated levels of gases under all conditions. The proprietary metal oxide (MOx) used in the sensor ensures that the sensor module can respond effectively to changing TVOC during long-term operation. Therefore, the user focus should always be on the relevant output parameters: The IAQ level according to UBA, the TVOC concentration (available in mg/m³ and as Ethanol equivalent in ppm), and/or the estimation of carbon dioxide (eCO₂).

For implementing the sensor module in a customer-specific application, detailed information on the programming is available. More information and guidance on the firmware integration, architecture, and supported platforms are available in the *ZMOD4410 Programming Manual – Read Me*. Code Examples in C and additional firmware descriptions for API, HAL, libraries, etc., are included at no cost in the downloadable firmware package from the [ZMOD4410](#) product page.

6. Assembly Restrictions, Operation, Integration Notes, and Storage

When implementing the ZMOD4410 in electrical circuit boards a gas sensor module might react to chemicals during the assembly process and to outgassing components, such as resins from the printed circuit board (PCB) assembly. A standard soldering profile can be used to assemble the ZMOD4410 on the user's PCB and should fulfill the IPC/JEDEC J-STD-020C Standard ("Moisture/Reflow Sensitivity Classification for Non-hermetic Solid State Surface Mount Devices"). A typical lead-free reflow solder profile is shown in Figure 13. After assembly, an outgassing of the PCB and electronic components must be considered, especially when operating the sensor module at elevated temperatures. This will ultimately influence the sensor module signal and may dominate the air quality reading.

A PCB heat treatment before assembling the ZMOD4410 is recommended. After the gas sensor module assembly, no coating, cleaning, or ultrasonic bath should be applied to the PCB. Also, in case sensor module parts are contaminated during assembly or storage, it can be cleaned after assembly by using the cleaning library provided with the firmware to remove any contamination of solder vapor from the MOx surface (see ZMOD4410 Programming Manual). In case the sensor module does not show full performance after a cleaning cycle a change to the protection sticker package is recommended (see Ordering Information). Store the sensor module in an antistatic metallic bag with a low TVOC background after the sensor module is removed from its original packaging or the assembled PCB is populated. The optimal storage conditions are < 1ppm TVOC, < 10ppb O₃, < 10ppb NO₂, 10°C to 50°C, and humidity levels within 20% to 80%RH. If the sensor module is stored outside of these conditions for extended periods of time, the readings can exhibit a temporary offset. The sensor module can be reconditioned and brought back to its calibration state by operation for 24 hours to 48 hours in clean air.

To receive the *Renesas Gas Sensor Guidelines* with detailed information and on assembly, material outgassing, test and validation procedures, contact Renesas via the contact information on the last page.

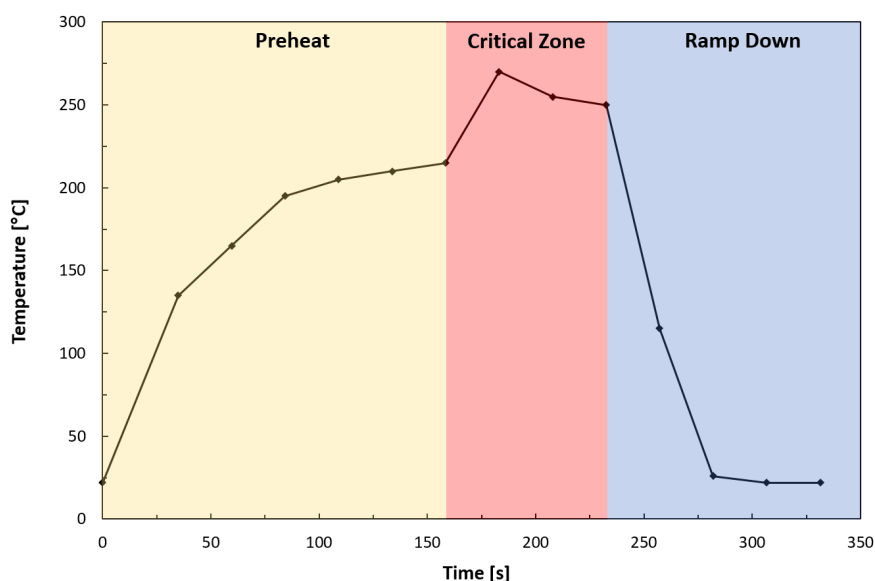

Figure 13. Typical Solder Profile

7. Test and Calibration

As a unique feature, all sampled gas sensor modules are fully tested during Renesas' final test. The final test parameters in Table 9 are applied for each ZMOD4410. All sensor modules are pre-stabilized in the final test although the user might see a small change in the module's raw signal during an initial warm-up phase during the first operation. The gas sensor module qualification is based on JEDEC (JESD47) and its subsequent standard (JESD22, JESD78, etc.); it has been qualified for a lifetime of 10 years. Renesas has proven a MOx lifetime of over 17 years in actual continuous operation in conditions without exposures to stressful environments.

Table 9. Final Test Parameters

Test	Test Object	Parameters	Test Results Saved in NVM?
Electrical	ASIC	Voltages, current consumption, frequencies, scan pattern	No
Electrical	Module	Calibration conditions, tracking ID, resistances	Yes
Gas	Module	Sensitivity parameters (slope and intercept) at stimulation with different gas concentrations	Yes
Gas	Module	Pre-stabilization	No

8. I2C Interface and Data Transmission Protocol

The I2C slave device interface supports various bus speeds: Standard Mode ($\leq 100\text{kHz}$) and Fast Mode ($\leq 400\text{kHz}$).

By default, the 7-bit slave address for the serial I2C data interface is set to 32_{HEX}. The implemented data transmission protocol is similar to the one used for conventional EEPROM devices. The register to read/write is selected by a register address pointer. This address pointer must be set during an I2C write operation. For read access a repeated START condition but no STOP condition should be sent. After transmission of a register, the address pointer is automatically incremented. A STOP condition ends the whole transmission. An increment from the address FF_{HEX} rolls over to 00_{HEX}.

For an example of the I2C data transmission protocol, see Figure 14. For information on I2C bus timing, see Figure 15. For I2C bus characteristics, see Table 10, which explains how to set up the interface. All other values are according to the I2C standard. Although the ZMOD4410 has an I2C interface, the user is not intended to modify any registers because a configuration change will affect the sensor module's performance, reliability, and accuracy. The API provided with the downloadable firmware package on the website manages all necessary sensor module communication.

To validate the general MCU-specific I2C read/write driver without the use of Renesas libraries, it is possible to write random values to registers 0x88 to 0x8B and read them afterwards. After this register testing, erase the testing code and reset the device by disconnecting the power support; otherwise the device may not operate properly.

WRITE Access RAM

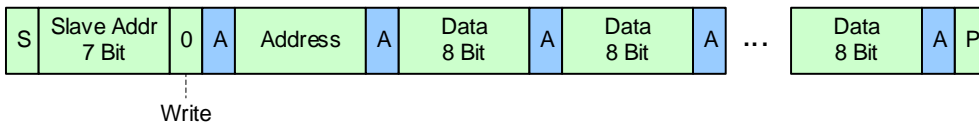

READ Access NVM and RAM

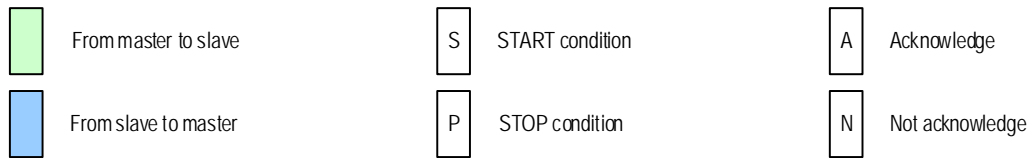
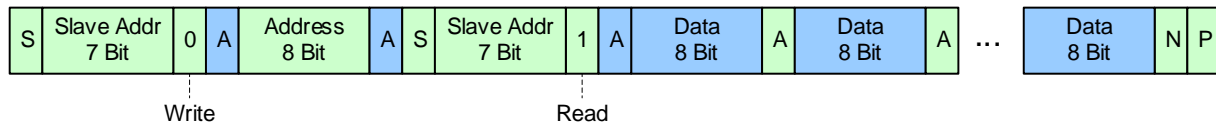

Figure 14. I2C Data Transmission Protocol

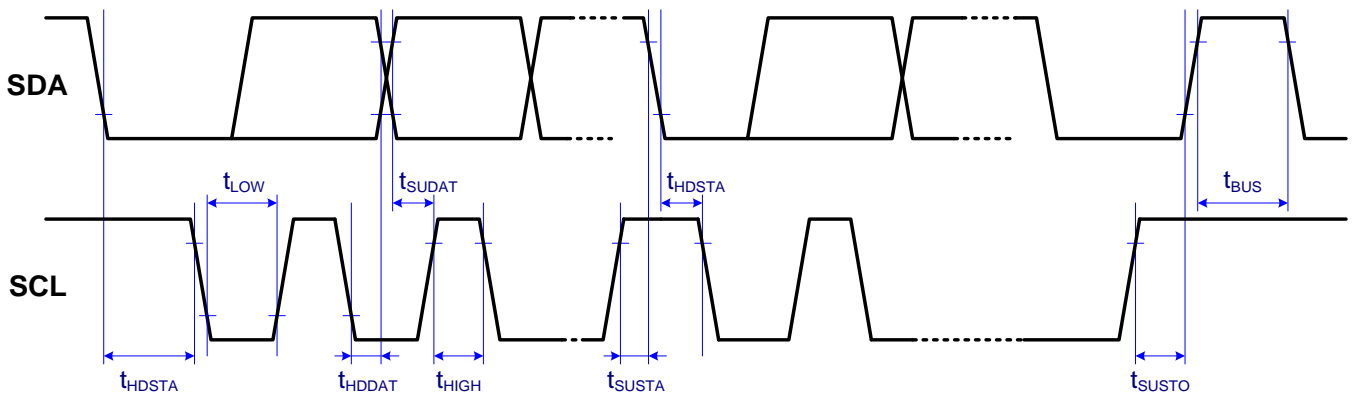

Figure 15. Bus Timing

Table 10. Bus Timing Characteristic

Parameter	Symbol	Standard Mode	Fast Mode	Unit
Maximum SCL clock frequency	f_{SCL}	100	400	kHz
Minimum START condition hold time relative to SCL edge	t_{HDSTA}	4		μs
Minimum SCL clock low width	t_{LOW}	4.7		μs
Minimum SCL clock high width	t_{HIGH}	4		μs
Minimum START condition setup time relative to SCL edge	t_{SUSTA}	4.7		μs
Minimum data hold time on SDA relative to SCL edge	t_{HDAT}	0		μs
Minimum data setup time on SDA relative to SCL edge	t_{SUDAT}	0.1	0.1	μs
Minimum STOP condition setup time on SCL	t_{SUSTO}	4		μs
Minimum bus free time between stop condition and start condition	t_{BUS}	4.7		μs

9. Related Websites and Software

Visit the [ZMOD4410](#) and [ZMOD4410 Evaluation Kit](#) (ZMOD4410-EVK) product pages to download software and the latest version of related documents, such as application notes, white papers, product briefs, and third-party reports.

Note that some documents require logging in with a free customer account, which can be set up under the “LOG IN” button on www.renesas.com. Some downloads require an additional step to complete a request form that appears when the link is clicked.

If additional support is needed for downloading, contact Renesas via the contact information on the last page.

10. Glossary

Term	Description
ADC	Analog-to-Digital Converter
AI	Artificial Intelligence
CDM	Charged Device Model
CM	Common Mode Generator
HBM	Human Body Model
IAQ 1 st Gen	Indoor Air Quality algorithm using traditional computing methods (legacy)
IAQ 2 nd Gen	Indoor Air Quality algorithm using machine learning AI
LGA	Land Grid Array
LV	Low Voltage
MOx	Metal Oxide
MSL	Moisture Sensitivity Level
Mux	Multiplexer
n.a.	Not Applicable
NVM	Nonvolatile Memory
PBAQ	Public Building Air Quality
POR	Power-On Reset
SDA	Serial Data
SCL	Serial Clock
SSC	Sensor Signal Conditioner
TST	Test
TVOC	Total Volatile Organic Compounds
UBA	Umweltbundesamt (German Federal Environmental Agency)

11. Package Outline Drawings

The ZMOD4410's different packages are listed in Table 11.

Table 11. Package Options

Part Number	Version	Comment	Package Link
ZMOD4410A11	Standard	Standard package	LGG12D1 package
ZMOD4410A12	Sticker	This package shipped with a sticker on top of the lid to protect sensor during assembly. Note, the sticker has to be removed after assembly.	
ZMOD4410A13	Waterproof	This package uses a membrane to get IP67 rating.	LGG12D2 package
ZMOD4410A14	Waterproof + Sticker	This package uses a membrane to get IP67 rating and is shipped with a sticker on top of the lid to protect sensor during assembly. Note, the sticker has to be removed after assembly.	

12. Marking Diagram

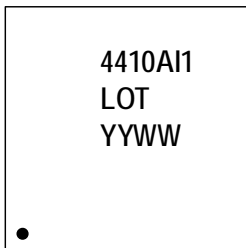

1. Line 1 is the truncated part number.
2. Line 2 – “LOT” denotes the assembly lot number.
3. Line 2 – “YYWW” are the last two digit of the year and week that the part was assembled.

13. Ordering Information

Part Number	Description and Package	MSL Rating	Carrier Type	Temp. Range
ZMOD4410AI1V	ZMOD4410 Sensor Module, 3.0 × 3.0 × 0.7 mm 12-LGA	3	Tray	-40°C to +65°C
ZMOD4410AI1R	ZMOD4410 Sensor Module, 3.0 × 3.0 × 0.7 mm 12-LGA	3	Reel	-40°C to +65°C
ZMOD4410AI2V	ZMOD4410 Sensor Module, 3.0 × 3.0 × 0.7 mm 12-LGA, shipped with <i>removable protection sticker</i>	3	Tray	-40°C to +65°C
ZMOD4410AI2R	ZMOD4410 Sensor Module, 3.0 × 3.0 × 0.7 mm 12-LGA, shipped with <i>removable protection sticker</i>	3	Reel	-40°C to +65°C
ZMOD4410AI3V	ZMOD4410 Sensor Module, 3.0 × 3.0 × 0.9 mm 12-LGA, <i>IP67 rating</i>	3	Tray	-40°C to +65°C
ZMOD4410AI3R	ZMOD4410 Sensor Module, 3.0 × 3.0 × 0.9 mm 12-LGA <i>IP67 rating</i>	3	Reel	-40°C to +65°C
ZMOD4410AI4V	ZMOD4410 Sensor Module, 3.0 × 3.0 × 0.9 mm 12-LGA, shipped with removable protection sticker and IP67 rating	3	Tray	-40°C to +65°C
ZMOD4410AI4R	ZMOD4410 Sensor Module, 3.0 × 3.0 × 0.9 mm 12-LGA, shipped with removable protection sticker and IP67 rating	3	Reel	-40°C to +65°C
ZMOD4410-EVK-HC	ZMOD4410 Evaluation Kit including the ZMOD4410 Sensor Board, ZMOD4410 HiCom Communication Board (USB Interface), and Micro-USB Cable. (The ZMOD4410 Evaluation Software is available for download free of charge on the ZMOD4410-EVK product page.)			
ZMOD4410-EVK-HC-WP	ZMOD4410 Evaluation Kit including the ZMOD4410 Sensor Board with IP67 rating, ZMOD4410 HiCom Communication Board (USB Interface), and Micro-USB Cable. (The ZMOD4410 Evaluation Software is available for download free of charge on ZMOD4410-EVK product page.)			

14. Revision History

Revision	Date	Description of Change
1.14	Mar 10, 2023	<ul style="list-style-type: none"> Updated to include a broader definition of Public Building Air Quality
1.13	Jan 31, 2023	<ul style="list-style-type: none"> Added information about WELL operation.
1.12	Aug 26, 2022	<ul style="list-style-type: none"> Updated with Relative IAQ operation mode (Odor operation mode Legacy) Information on Hydrogen (H2) and sensor status Migrated the document to the latest template
-	Dec 17, 2021	<ul style="list-style-type: none"> Updated with Ultra-Low Power Operation Mode for IAQ 2nd Gen Added data for accuracy and consistency Completed minor changes throughout
-	Jun 30, 2021	<ul style="list-style-type: none"> Updated improved lifetime Added a description of firmware and algorithms Add a marking diagram Updated URL
-	Nov 30, 2020	<ul style="list-style-type: none"> Updated "Conditioning, Sensor Self-Check Status, and Stability" Completed minor changes throughout
-	Nov 2, 2020	<ul style="list-style-type: none"> Added ZMOD4410 sensor module packages for Assembly Protection and IP67 Rating Minor updates in language
-	Jun 3, 2020	<ul style="list-style-type: none"> Completed minor edits.
-	Jun 1, 2020	<ul style="list-style-type: none"> Changed to Renesas layout Added RoHS compliance Updated NVM data space Updated with Operation Mode for IAQ 2nd Gen Updated with Operation Mode for Sulfur based odor discrimination
-	Jul 30, 2019	<ul style="list-style-type: none"> MSL rating corrected in the Ordering table.
-	May 9, 2019	<ul style="list-style-type: none"> Addition of storage conditions. Improved programming description for customer-specific applications. Improved pin description for INT. Addition of lifetime for qualification. Addition of the "Related Website and Software" section.
-	Mar 12, 2019	<ul style="list-style-type: none"> Update to add I2C specification. Update figure for humidity influence. Update to add disclaimer for safety-related applications in section 4.1. Minor edits.
-	Nov 2, 2018	<ul style="list-style-type: none"> Update with Low Power Operation Method.
-	Sep 24, 2018	<ul style="list-style-type: none"> Update for operation methods for trigger/control signal option. Update for power consumption and minor update in electrical characteristics. Update references.
-	Sep 1, 2018	<ul style="list-style-type: none"> Initial release.

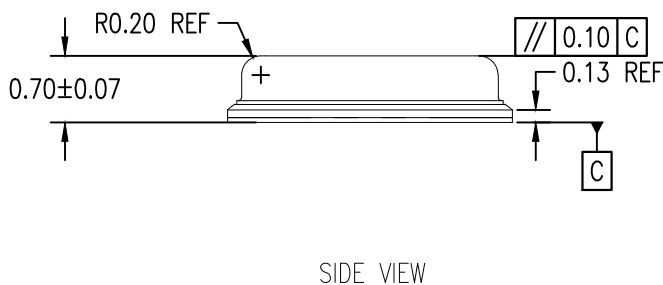
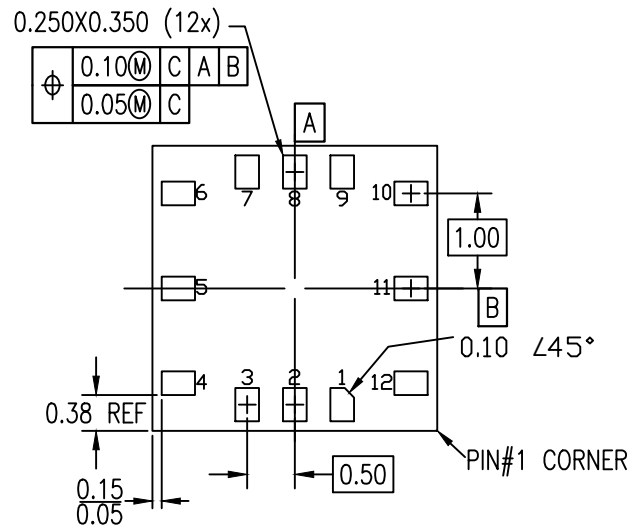
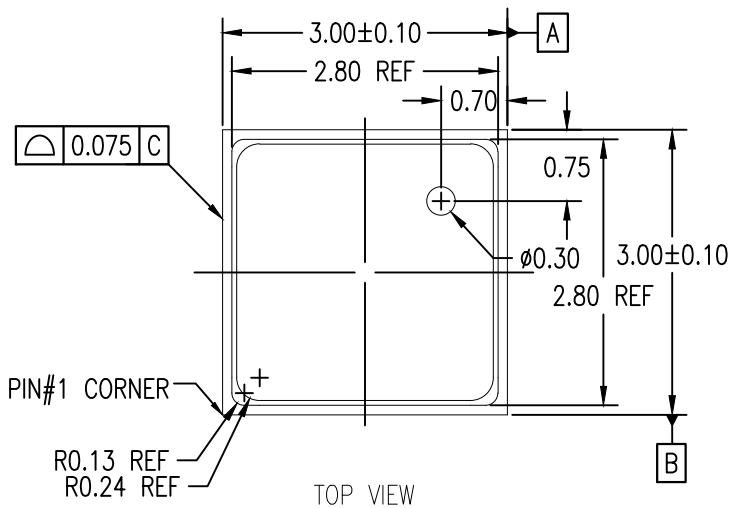

NOTES:

1. ALL DIMENSIONING AND TOLERANCING CONFORM TO ANSI Y14.5M-1982
2. ALL DIMENSION ARE IN MILLIMETERS.
3. UNLESS SPECIFIED, THE TOLERANCE OF ± 0.05 MM APPLIES TO DIMENSIONS OF 2 DECIMALS, AND ± 0.012 MM APPLIES TO DIMENSIONS OF 3 DECIMALS.

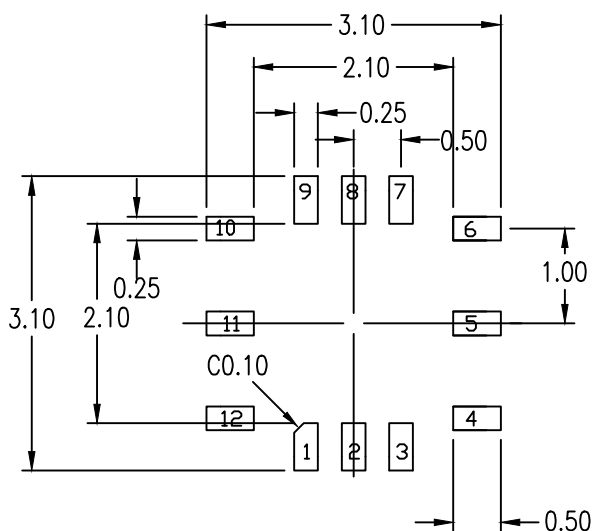

RECOMMENDED LAND PATTERN DIMENSION

NOTES:

1. ALL DIMENSION ARE IN MM. ANGLES IN DEGREES.
2. TOP DOWN VIEW. AS VIEWED ON PCB.
3. NSMD LAND PATTERN ASSUMED.
4. LAND PATTERN RECOMMENDATION PER IPC-7351B GENERIC REQUIREMENT FOR SURFACE MOUNT DESIGN AND LAND PATTERN.

Package Revision History

Date Created	Rev No.	Description
Sept 12, 2019	Rev 01.	Add Dimension on Gal Inlet Hole
Dec 17, 2019	Rev 02	Add Location Dimension Gal Inlet
Mar 10, 2021	Rev 03	Add Tolerance for Entire Body
Apr 27, 2022	Rev 04	Remove PDF SHX
June 20, 2023	Rev 05	Changed body size tolerance to standard tolerance

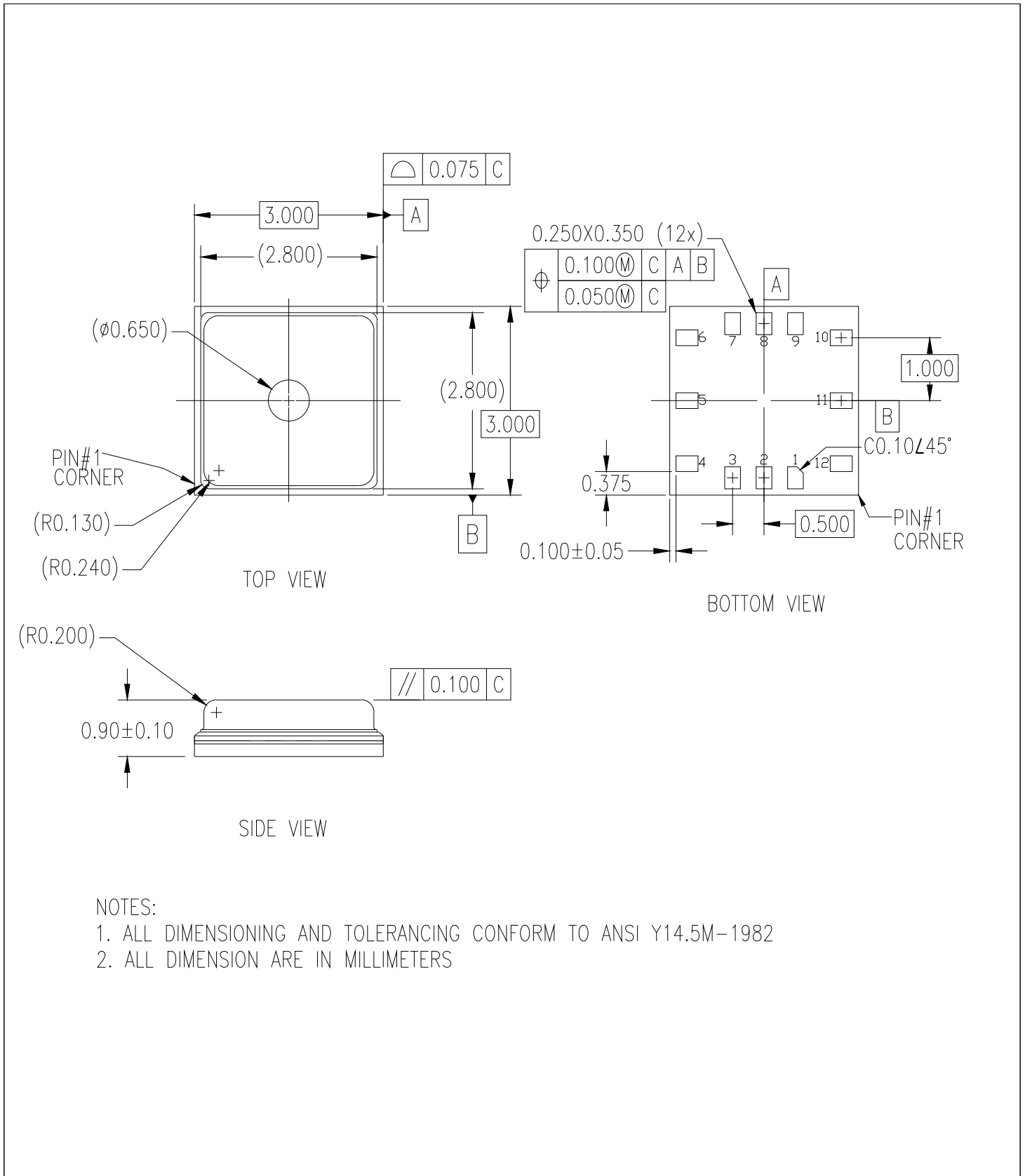

NOTES:

1. ALL DIMENSIONING AND TOLERANCING CONFORM TO ANSI Y14.5M-1982
2. ALL DIMENSION ARE IN MILLIMETERS

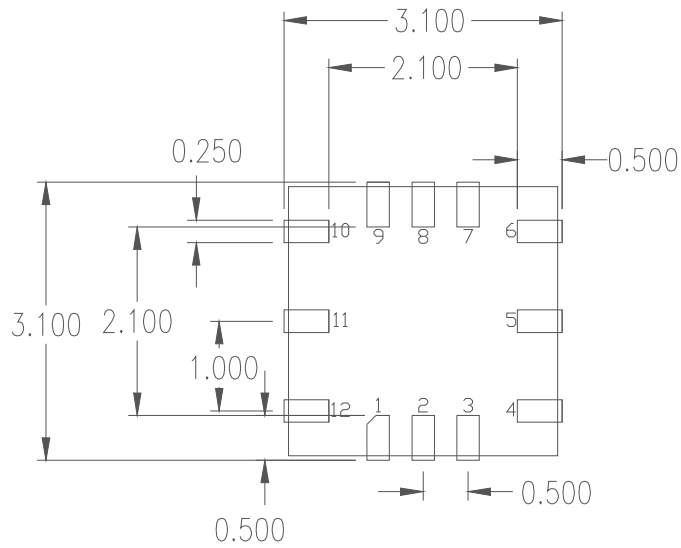

RECOMMENDED LAND PATTERN DIMENSION

NOTES:

1. ALL DIMENSION ARE IN MM. ANGLES IN DEGREES
2. TOP DOWN VIEW ON PCB
3. LAND PATTERN RECOMMENDATION PER IPC-7351B GENERIC REQUIREMENT FOR SURFACE MOUNT DESIGN AND LAND PATTERN

Date Created	Rev No.	Package Revision History
April 24, 2020	Rev 00	Initial release

IMPORTANT NOTICE AND DISCLAIMER

RENESAS ELECTRONICS CORPORATION AND ITS SUBSIDIARIES (“RENESAS”) PROVIDES TECHNICAL SPECIFICATIONS AND RELIABILITY DATA (INCLUDING DATASHEETS), DESIGN RESOURCES (INCLUDING REFERENCE DESIGNS), APPLICATION OR OTHER DESIGN ADVICE, WEB TOOLS, SAFETY INFORMATION, AND OTHER RESOURCES “AS IS” AND WITH ALL FAULTS, AND DISCLAIMS ALL WARRANTIES, EXPRESS OR IMPLIED, INCLUDING, WITHOUT LIMITATION, ANY IMPLIED WARRANTIES OF MERCHANTABILITY, FITNESS FOR A PARTICULAR PURPOSE, OR NON-INFRINGEMENT OF THIRD PARTY INTELLECTUAL PROPERTY RIGHTS.

These resources are intended for developers skilled in the art designing with Renesas products. You are solely responsible for (1) selecting the appropriate products for your application, (2) designing, validating, and testing your application, and (3) ensuring your application meets applicable standards, and any other safety, security, or other requirements. These resources are subject to change without notice. Renesas grants you permission to use these resources only for development of an application that uses Renesas products. Other reproduction or use of these resources is strictly prohibited. No license is granted to any other Renesas intellectual property or to any third party intellectual property. Renesas disclaims responsibility for, and you will fully indemnify Renesas and its representatives against, any claims, damages, costs, losses, or liabilities arising out of your use of these resources. Renesas' products are provided only subject to Renesas' Terms and Conditions of Sale or other applicable terms agreed to in writing. No use of any Renesas resources expands or otherwise alters any applicable warranties or warranty disclaimers for these products.

(Disclaimer Rev.1.0 Mar 2020)

Corporate Headquarters

TOYOSU FORESIA, 3-2-24 Toyosu,
Koto-ku, Tokyo 135-0061, Japan
www.renesas.com

Contact Information

For further information on a product, technology, the most up-to-date version of a document, or your nearest sales office, please visit:
www.renesas.com/contact/

Trademarks

Renesas and the Renesas logo are trademarks of Renesas Electronics Corporation. All trademarks and registered trademarks are the property of their respective owners.