

HIGH VOLTAGE CONTACTORS ECK150 SERIES

INTRODUCTION

ECK150 series high-voltage DC contactor is designed for control in new energy applications. The ECK150 product line is an innovative and reliable solution for EV charging stations, solar inverters, battery energy storage systems, automated-guided vehicles (AGV) and e-Forklifts. ECK150 is hermetically sealed with ceramic technology and enable high switching capability under 1000VDC. The built-in PWM module design makes it smaller to save space.

FEATURES

- Hermetically sealed with ceramic technology
- Designed with built-in economizer, hold power 1.7W
- Maximum DC breaking current at 1500A
- Maximum DC breaking voltage at 1000VDC
- Auxiliary contact version available
- Comply with DC-1 utilization category in IEC60947-4-1

APPLICATION

- DC Charging station
- Electric vehicle
- AGV
- Electric forklift
- Energy storage systems
- Photovoltaic inverter

APPROVALS

- CCC: 2022960304002220
- CE: 724-00004
- UL: E82292
- TUV: CN221S2D 002

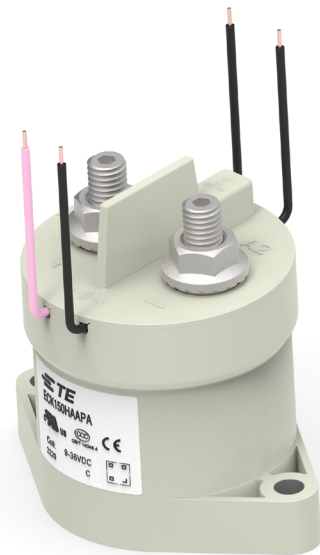

High Voltage Contactors ECK150 Series

Contact Data

Contact current	200A
Max. Switching voltage	1000VDC
Contact arrangement	1 Form X (SPST-NO-DM)
Initial contact resistance	≤ 0.4mΩ (150A, after 1 minute)
Operate time, max. (At 23°C)	30ms
Release time, max. (At 23°C)	10ms
Mechanical life	
With auxiliary contact	200,000 cycles
Without auxiliary contact	500,000 cycles

Contact Ratings

Load	Cycles
150A, 450VDC, make/break, resistive	6000
150A, 1000VDC, make/break, resistive	1000

Note:

- Only typical rating listed, please refer to make/break curves in next page for more details at different current and voltage.

Other Data

Material compliance:EU RoHS/ELV, China RoHS, REACH, Halogen content refer to the product Compliance Support Center at www.te.com/customersupport/rohssupportcenter	
Ambient temperature	-40°C to 85°C
Vibration resistance (functional)	Sine, 10-2000Hz, 6G
Shock resistance (functional)	11ms 1/2 Sine, Peak 20G
Terminal type	Screw for contact, wire for coil
Weight	380g
Packaging/Unit	Box/24 pcs.

Coil versions, DC Coil

Coil Code	Nominal Voltage	Nominal Operate Current	Max Starting Current	Operate Voltage	Maximum Operate Voltage	Release Voltage	Coil Power
A	9-36VDC	0.13A@12VDC 0.07A@24VDC	3.6A	≤9VDC	36VDC	≥3VDC	Start: 43.2W Hold: 1.7W

All figures are given for coil without pre-energization, at ambient temperature +23°C.

CE Declaration (IEC60947-4-1)

Rated Operational Current	Utilization Category	Switching Cycles
100A	DC-1	6,050

Auxiliary Contact Data

Contact form	1 Form A (SPST-NO)
Contact current, Max.	2A, 30VDC
Contact current, Min.	10mA, 24VDC
Contact resistance, Max.	0.4Ω @ 30VDC

Insulation Data

Dielectric Withstand Voltage (leakage current <1mA)	
Between open main contacts	3500Vrms
Between main contact and coil	3500Vrms
Between main contacts and aux contacts	3500Vrms
Between open aux contacts	750Vrms
Initial Insulation Resistance @ 1000VDC	
Between insulated elements	> 1x10 ⁹ Ω

High Voltage Contactors ECK150 Series

Current Carrying Capability Curve

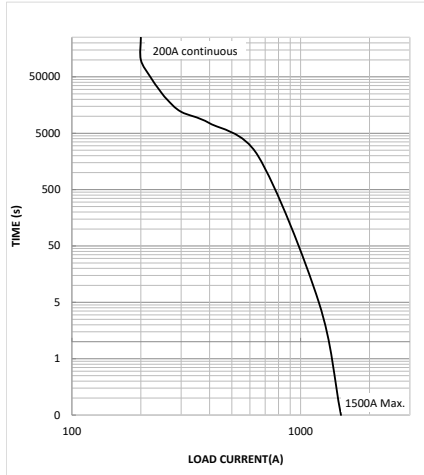

Note:

- The data is measured at the environment temperature 85°C with cross section area of wire 95mm² min. Smaller conductor are also allowed depending on the end users thermal conditions.

Estimated Make & Break Power Switching Ratings

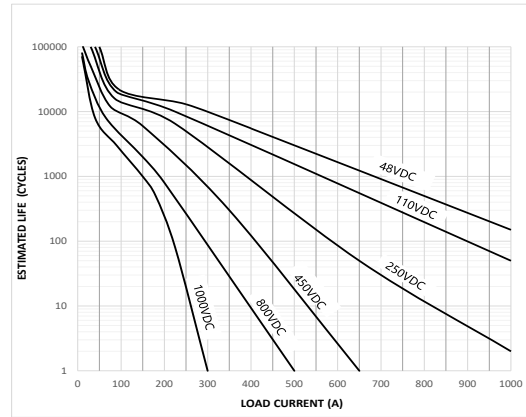

Note:

- The curve was created based on extrapolated data with few typical points, users are recommended to confirm performance in actual application.
- The typical data were estimated with resistive load at room temperature.

Dimension

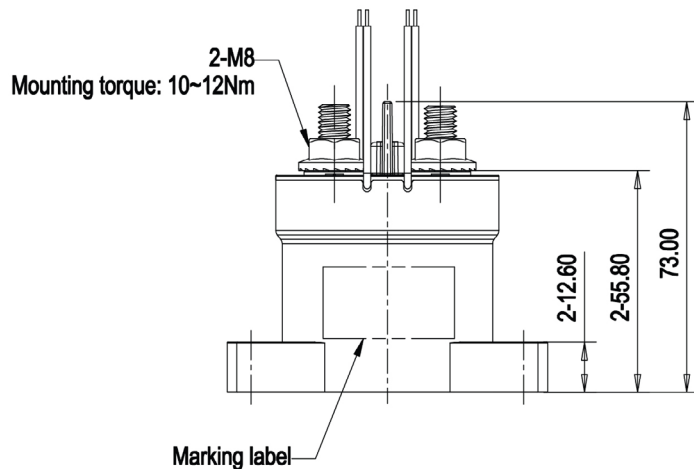

Note:

- Main contact terminal connection and coil connection with positive and negative difference.

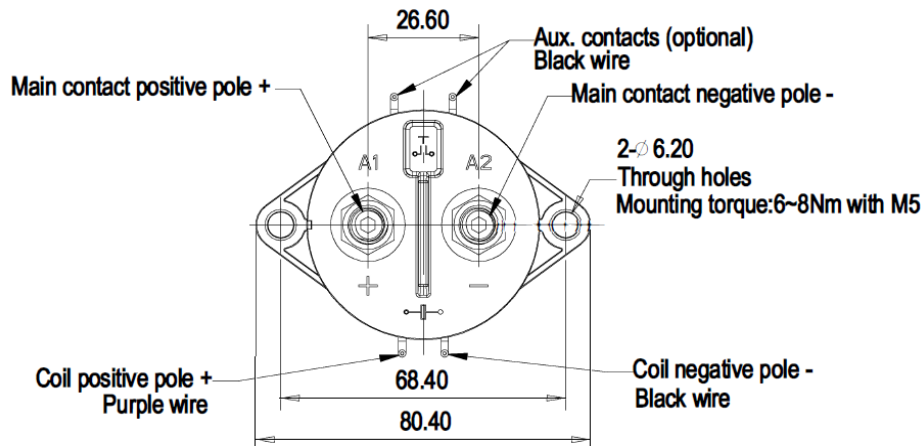
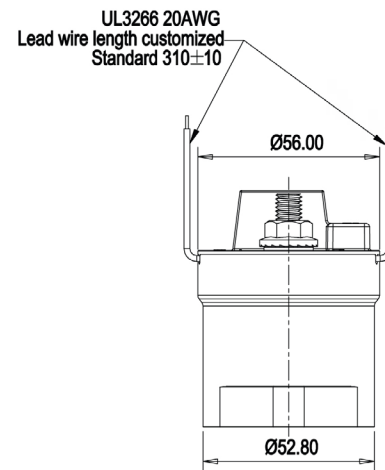

Circuit Diagram

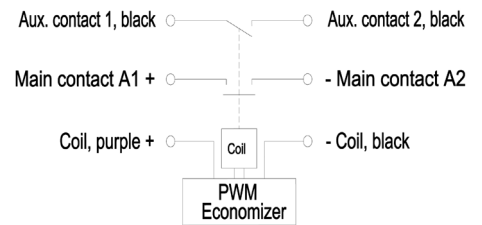

General Tolerance	
Dimension	Tolerance
<10	±0.3
10 - 50	±0.6
>50	±1.0

ORDERING INFORMATION

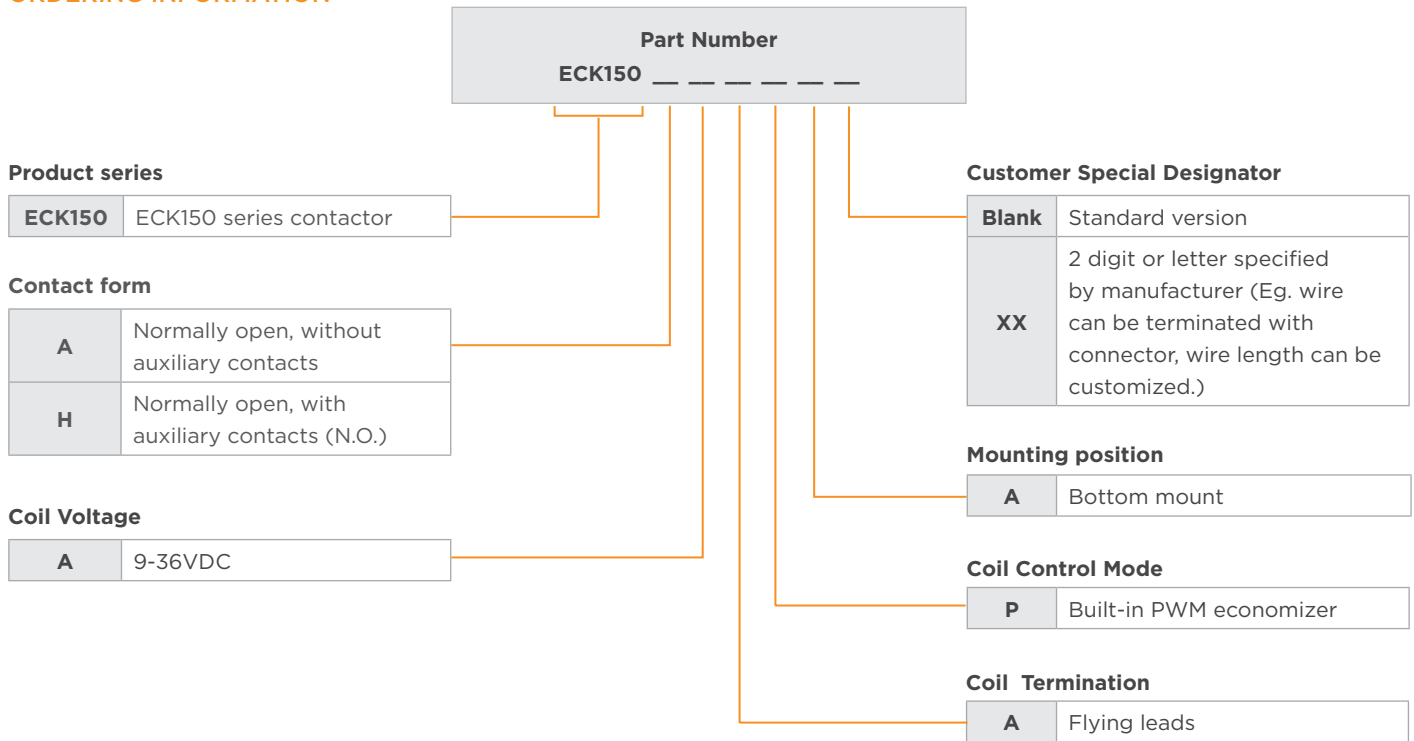

PRODUCT PART NUMBER TABLE

Product Code	Contact Form	Mounting Position	Coil	Coil Control Mode	Part Number
ECK150AAAPA	Normally open, without auxiliary contacts	Bottom	9-36VDC	Built-in PWM economizer	2071567-2
ECK150HAAPA	Normally open, with auxiliary contacts (N.O.)				2071567-1

Note: Only typical part numbers are listed above, other types please contact TE engineer.

CAUTIONS

- Do not use the product when product is dropped or broken.
- Avoid mounting the contactor with the main contact screw terminals in downward direction, otherwise the contactor performance will not be guaranteed.
- Please use correctly according to the mark on the surface of the product. Main contact terminals and coil wires have polarity difference. When the connection polarity is reversed, the electrical characteristics promised in the datasheet will not be guaranteed.
- There are diodes built in the PWM economizer of the coil inside the contactor, additional diodes are not required.
- Please consider electromagnetic interference when using the product.
- Screw locking torque of main contact terminals should be 10-12 N·m for M8 screw. Screw locking torque of product bottom mounting should be 6-8 N·m for M5 screw.
- Suitable for applications under Uimp 6kV.

te.com

©2022 TE Connectivity. All Rights Reserved.

TE Connectivity, TE Connectivity (logo) and Every Connection Counts are trademarks. All other logos, products and/or company names referred to herein might be trademarks of their respective owners.

The information given herein, including drawings, illustrations and schematics which are intended for illustration purposes only, is believed to be reliable. However, TE Connectivity makes no warranties as to its accuracy or completeness and disclaims any liability in connection with its use. TE Connectivity's obligations shall only be as set forth in TE Connectivity's Standard Terms and Conditions of Sale for this product and in no case will TE Connectivity be liable for any incidental, indirect or consequential damages arising out of the sale, resale, use or misuse of the product. Users of TE Connectivity products should make their own evaluation to determine the suitability of each such product for the specific application.

Issue Date: 11/23 ED