



SIRIUS soft starter 200-480 V 171 A, 110-250 V AC spring-type terminals
Analog output

product brand name	SIRIUS
product category	Hybrid switching devices
product designation	Soft starter
product type designation	3RW52
manufacturer's article number	
<ul style="list-style-type: none"> • of standard HMI module usable 	3RW5980-0HS00
<ul style="list-style-type: none"> • of high feature HMI module usable 	3RW5980-0HF00
<ul style="list-style-type: none"> • of communication module PROFINET standard usable 	3RW5980-0CS00
<ul style="list-style-type: none"> • of communication module PROFIBUS usable 	3RW5980-0CP00
<ul style="list-style-type: none"> • of communication module Modbus TCP usable 	3RW5980-0CT00
<ul style="list-style-type: none"> • of communication module Modbus RTU usable 	3RW5980-0CR00
<ul style="list-style-type: none"> • of communication module Ethernet/IP 	3RW5980-0CE00
<ul style="list-style-type: none"> • of circuit breaker usable at 400 V 	3VA2325-7MN32-0AA0; Type of coordination 1, I _q = 30 kA, CLASS 10
<ul style="list-style-type: none"> • of circuit breaker usable at 500 V 	3VA2325-7MN32-0AA0; Type of coordination 1, I _q = 10 kA, CLASS 10
<ul style="list-style-type: none"> • of circuit breaker usable at 400 V at inside-delta circuit 	3VA2440-7MN32-0AA0; Type of coordination 1, I _q = 30 kA, CLASS 10
<ul style="list-style-type: none"> • of circuit breaker usable at 500 V at inside-delta circuit 	3VA2440-7MN32-0AA0; Type of coordination 1, I _q = 10 kA, CLASS 10
<ul style="list-style-type: none"> • of the gG fuse usable up to 690 V 	3NA3365-6; Type of coordination 1, I _q = 65 kA
<ul style="list-style-type: none"> • of the gG fuse usable at inside-delta circuit up to 500 V 	3NA3365-6; Type of coordination 1, I _q = 65 kA
<ul style="list-style-type: none"> • of full range R fuse link for semiconductor protection usable up to 690 V 	3NE1230-0; Type of coordination 2, I _q = 65 kA
<ul style="list-style-type: none"> • of back-up R fuse link for semiconductor protection usable up to 690 V 	3NE3335; Type of coordination 2, I _q = 65 kA
General technical data	
starting voltage [%]	30 ... 100 %
stopping voltage [%]	50 ... 50 %
start-up ramp time of soft starter	0 ... 20 s
current limiting value [%] adjustable	130 ... 700 %
certificate of suitability	
<ul style="list-style-type: none"> • CE marking 	Yes
<ul style="list-style-type: none"> • UL approval 	Yes
<ul style="list-style-type: none"> • CSA approval 	Yes
product component is supported	
<ul style="list-style-type: none"> • HMI-Standard 	Yes
<ul style="list-style-type: none"> • HMI-High Feature 	Yes
product feature integrated bypass contact system	Yes

number of controlled phases	3
trip class	CLASS 10A (default) / 10E / 20E; acc. to IEC 60947-4-2
buffering time in the event of power failure	
• for main current circuit	100 ms
• for control circuit	100 ms
insulation voltage rated value	600 V
degree of pollution	3, acc. to IEC 60947-4-2
impulse voltage rated value	6 kV
blocking voltage of the thyristor maximum	1 400 V
service factor	1
surge voltage resistance rated value	6 kV
maximum permissible voltage for safe isolation	
• between main and auxiliary circuit	600 V
utilization category acc. to IEC 60947-4-2	AC 53a
shock resistance	15 g / 11 ms, from 12 g / 11 ms with potential contact lifting
vibration resistance	15 mm to 6 Hz; 2g to 500 Hz
reference code acc. to IEC 81346-2	Q
product function	
• ramp-up (soft starting)	Yes
• ramp-down (soft stop)	Yes
• Soft Torque	Yes
• adjustable current limitation	Yes
• pump ramp down	Yes
• intrinsic device protection	Yes
• motor overload protection	Yes; Electronic motor overload protection
• evaluation of thermistor motor protection	No
• inside-delta circuit	Yes
• auto-RESET	Yes
• manual RESET	Yes
• remote reset	Yes; By turning off the control supply voltage
• communication function	Yes
• operating measured value display	Yes; Only in conjunction with special accessories
• error logbook	Yes; Only in conjunction with special accessories
• via software parameterizable	No
• via software configurable	Yes
• PROFInergy	Yes; in connection with the PROFINET Standard communication module
• firmware update	Yes
• removable terminal for control circuit	Yes
• torque control	No
• analog output	Yes; 4 ... 20 mA (default) / 0 ... 10 V (parameterizable with High Feature HMI)
Power Electronics	
operational current	
• at 40 °C rated value	171 A
• at 50 °C rated value	153 A
• at 60 °C rated value	141 A
operational current at inside-delta circuit	
• at 40 °C rated value	296 A
• at 50 °C rated value	265 A
• at 60 °C rated value	244 A
operating voltage	
• rated value	200 ... 480 V
• at inside-delta circuit rated value	200 ... 480 V
relative negative tolerance of the operating voltage	-15 %
relative positive tolerance of the operating voltage	10 %
relative negative tolerance of the operating voltage at inside-delta circuit	-15 %
relative positive tolerance of the operating voltage at	10 %

inside-delta circuit	
operating power for 3-phase motors	
• at 230 V at 40 °C rated value	45 kW
• at 230 V at inside-delta circuit at 40 °C rated value	90 kW
• at 400 V at 40 °C rated value	90 kW
• at 400 V at inside-delta circuit at 40 °C rated value	160 kW
Operating frequency 1 rated value	50 Hz
Operating frequency 2 rated value	60 Hz
relative negative tolerance of the operating frequency	-10 %
relative positive tolerance of the operating frequency	10 %
adjustable motor current	
• at rotary coding switch on switch position 1	81 A
• at rotary coding switch on switch position 2	87 A
• at rotary coding switch on switch position 3	93 A
• at rotary coding switch on switch position 4	99 A
• at rotary coding switch on switch position 5	105 A
• at rotary coding switch on switch position 6	111 A
• at rotary coding switch on switch position 7	117 A
• at rotary coding switch on switch position 8	123 A
• at rotary coding switch on switch position 9	129 A
• at rotary coding switch on switch position 10	135 A
• at rotary coding switch on switch position 11	141 A
• at rotary coding switch on switch position 12	147 A
• at rotary coding switch on switch position 13	153 A
• at rotary coding switch on switch position 14	159 A
• at rotary coding switch on switch position 15	165 A
• at rotary coding switch on switch position 16	171 A
• minimum	81 A
adjustable motor current	
• for inside-delta circuit at rotary coding switch on switch position 1	140 A
• for inside-delta circuit at rotary coding switch on switch position 2	151 A
• for inside-delta circuit at rotary coding switch on switch position 3	161 A
• for inside-delta circuit at rotary coding switch on switch position 4	171 A
• for inside-delta circuit at rotary coding switch on switch position 5	182 A
• for inside-delta circuit at rotary coding switch on switch position 6	192 A
• for inside-delta circuit at rotary coding switch on switch position 7	203 A
• for inside-delta circuit at rotary coding switch on switch position 8	213 A
• for inside-delta circuit at rotary coding switch on switch position 9	223 A
• for inside-delta circuit at rotary coding switch on switch position 10	234 A
• for inside-delta circuit at rotary coding switch on switch position 11	244 A
• for inside-delta circuit at rotary coding switch on switch position 12	255 A
• for inside-delta circuit at rotary coding switch on switch position 13	265 A
• for inside-delta circuit at rotary coding switch on switch position 14	275 A
• for inside-delta circuit at rotary coding switch on switch position 15	286 A
• for inside-delta circuit at rotary coding switch on switch position 16	296 A
• at inside-delta circuit minimum	140 A

minimum load [%]	15 %; Relative to smallest settable le
power loss [W] for rated value of the current at AC	
• at 40 °C after startup	63 W
• at 50 °C after startup	58 W
• at 60 °C after startup	54 W
power loss [W] at AC at current limitation 350 %	
• at 40 °C during startup	2 405 W
• at 50 °C during startup	2 037 W
• at 60 °C during startup	1 826 W
Control circuit/ Control	
type of voltage of the control supply voltage	AC
• control supply voltage at AC at 50 Hz	110 ... 250 V
• control supply voltage at AC at 60 Hz	110 ... 250 V
relative negative tolerance of the control supply voltage at AC at 50 Hz	-15 %
relative positive tolerance of the control supply voltage at AC at 50 Hz	10 %
relative negative tolerance of the control supply voltage at AC at 60 Hz	-15 %
relative positive tolerance of the control supply voltage at AC at 60 Hz	10 %
control supply voltage frequency	50 ... 60 Hz
relative negative tolerance of the control supply voltage frequency	-10 %
relative positive tolerance of the control supply voltage frequency	10 %
control supply current in standby mode rated value	30 mA
holding current in bypass operation rated value	75 mA
locked-rotor current at close of bypass contact maximum	2.5 A
inrush current peak at application of control supply voltage maximum	12.2 A
duration of inrush current peak at application of control supply voltage	2.2 ms
design of the overvoltage protection	Varistor
design of short-circuit protection for control circuit	4 A gG fuse (I _{cu} =1 kA), 6 A quick-acting fuse (I _{cu} =1 kA), C1 miniature circuit breaker (I _{cu} = 600 A), C6 miniature circuit breaker (I _{cu} = 300 A); Is not part of scope of supply
Inputs/ Outputs	
number of digital inputs	1
number of inputs for thermistor connection	0
number of digital outputs	3
• not parameterizable	2
digital output version	2 normally-open contacts (NO) / 1 changeover contact (CO)
number of analog outputs	1
switching capacity current of the relay outputs	
• at AC-15 at 250 V rated value	3 A
• at DC-13 at 24 V rated value	1 A
Installation/ mounting/ dimensions	
mounting position	with vertical mounting surface +/-90° rotatable, with vertical mounting surface +/- 22.5° tiltable to the front and back
fastening method	screw fixing
height	306 mm
width	185 mm
depth	203 mm
required spacing with side-by-side mounting	
• forwards	10 mm
• backwards	0 mm
• upwards	100 mm
• downwards	75 mm
• at the side	5 mm

weight without packaging	7.15 kg
Connections/ Terminals	
type of electrical connection	busbar connection spring-loaded terminals
<ul style="list-style-type: none"> for main current circuit for control circuit 	
width of connection bar maximum	25 mm
type of connectable conductor cross-sections	
<ul style="list-style-type: none"> for DIN cable lug for main contacts stranded for DIN cable lug for main contacts finely stranded 	2x (16 ... 95 mm ²) 2x (25 ... 120 mm ²)
type of connectable conductor cross-sections	
<ul style="list-style-type: none"> for control circuit solid for control circuit finely stranded with core end processing at AWG cables for control circuit solid at AWG cables for control circuit finely stranded with core end processing 	2x (0.25 ... 1.5 mm ²) 2x (0.25 ... 1.5 mm ²) 2x (24 ... 16) 2x (24 ... 16)
wire length	
<ul style="list-style-type: none"> between soft starter and motor maximum at the digital inputs at AC maximum 	800 m 100 m
tightening torque	
<ul style="list-style-type: none"> for main contacts with screw-type terminals for auxiliary and control contacts with screw-type terminals 	10 ... 14 N·m 0.8 ... 1.2 N·m
tightening torque [lbf·in]	
<ul style="list-style-type: none"> for main contacts with screw-type terminals for auxiliary and control contacts with screw-type terminals 	89 ... 124 lbf·in 7 ... 10.3 lbf·in
Ambient conditions	
installation altitude at height above sea level maximum	5 000 m; Derating as of 1000 m, see catalog
<ul style="list-style-type: none"> ambient temperature during operation ambient temperature during storage and transport 	-25 ... +60 °C; Please observe derating at temperatures of 40 °C or above -40 ... +80 °C
environmental category	
<ul style="list-style-type: none"> during operation acc. to IEC 60721 during storage acc. to IEC 60721 during transport acc. to IEC 60721 	3K6 (no ice formation, only occasional condensation), 3C3 (no salt mist), 3S2 (sand must not get into the devices), 3M6 1K6 (only occasional condensation), 1C2 (no salt mist), 1S2 (sand must not get inside the devices), 1M4 2K2, 2C1, 2S1, 2M2 (max. fall height 0.3 m)
EMC emitted interference	acc. to IEC 60947-4-2: Class A
Communication/ Protocol	
communication module is supported	
<ul style="list-style-type: none"> PROFINET standard EtherNet/IP Modbus RTU Modbus TCP PROFIBUS 	Yes Yes Yes Yes Yes
UL/CSA ratings	
manufacturer's article number	
<ul style="list-style-type: none"> of circuit breaker <ul style="list-style-type: none"> usable for Standard Faults at 460/480 V according to UL usable for High Faults at 460/480 V according to UL usable for Standard Faults at 460/480 V at inside-delta circuit according to UL usable for High Faults at 460/480 V at inside-delta circuit according to UL usable for Standard Faults at 575/600 V according to UL usable for Standard Faults at 575/600 V at inside-delta circuit according to UL 	Siemens type: 3VA52, max. 250 A; I _q = 10 kA Siemens type: 3VA52, max. 250 A; I _q max = 65 kA Siemens type: 3VA52, max. 250 A; I _q = 10 kA Siemens type: 3VA52, max. 250 A; I _q max = 65 kA Siemens type: 3VA52, max. 250 A; I _q = 10 kA Siemens type: 3VA52, max. 250 A; I _q = 10 kA

<ul style="list-style-type: none"> • of the fuse <ul style="list-style-type: none"> — usable for Standard Faults up to 575/600 V according to UL — usable for High Faults up to 575/600 V according to UL — usable for Standard Faults at inside-delta circuit up to 575/600 V according to UL — usable for High Faults at inside-delta circuit up to 575/600 V according to UL 	Type: Class RK5 / K5, max. 400 A; Iq = 10 kA Type: Class J / L, max. 350 A; Iq = 100 kA Type: Class RK5 / K5, max. 400 A; Iq = 10 kA Type: Class J / L, max. 350 A; Iq = 100 kA
operating power [hp] for 3-phase motors <ul style="list-style-type: none"> • at 200/208 V at 50 °C rated value • at 220/230 V at 50 °C rated value • at 460/480 V at 50 °C rated value • at 200/208 V at inside-delta circuit at 50 °C rated value • at 220/230 V at inside-delta circuit at 50 °C rated value • at 460/480 V at inside-delta circuit at 50 °C rated value 	50 hp 50 hp 100 hp 75 hp 100 hp 200 hp
contact rating of auxiliary contacts according to UL	R300-B300

Safety related data	
protection class IP on the front acc. to IEC 60529	IP00; IP20 with cover
touch protection on the front acc. to IEC 60529	finger-safe, for vertical contact from the front with cover
electromagnetic compatibility	in accordance with IEC 60947-4-2

Certificates/ approvals	
General Product Approval	EMC



Declaration of Conformity	Test Certificates	Marine / Shipping
---------------------------	-------------------	-------------------



[Miscellaneous](#)

[Type Test Certificates/Test Report](#)



Marine / Shipping	other
-------------------	-------



[Confirmation](#)

[Confirmation](#)

Further information

Information- and Downloadcenter (Catalogs, Brochures,...)

<https://www.siemens.com/ic10>

Industry Mall (Online ordering system)

<https://mall.industry.siemens.com/mall/en/en/Catalog/product?mlfb=3RW5236-2AC14>

Cax online generator

<http://support.automation.siemens.com/WW/CAXorder/default.aspx?lang=en&mlfb=3RW5236-2AC14>

Service&Support (Manuals, Certificates, Characteristics, FAQs,...)

<https://support.industry.siemens.com/cs/ww/en/ps/3RW5236-2AC14>

Image database (product images, 2D dimension drawings, 3D models, device circuit diagrams, EPLAN macros, ...)

http://www.automation.siemens.com/bilddb/cax_de.aspx?mlfb=3RW5236-2AC14&lang=en

Characteristic: Tripping characteristics, I_t, Let-through current

<https://support.industry.siemens.com/cs/ww/en/ps/3RW5236-2AC14/char>

Characteristic: Installation altitude

<http://www.automation.siemens.com/bilddb/index.aspx?view=Search&mlfb=3RW5236-2AC14&objecttype=14&gridview=view1>

Simulation Tool for Soft Starters (STS)

<https://support.industry.siemens.com/cs/ww/en/view/101494917>

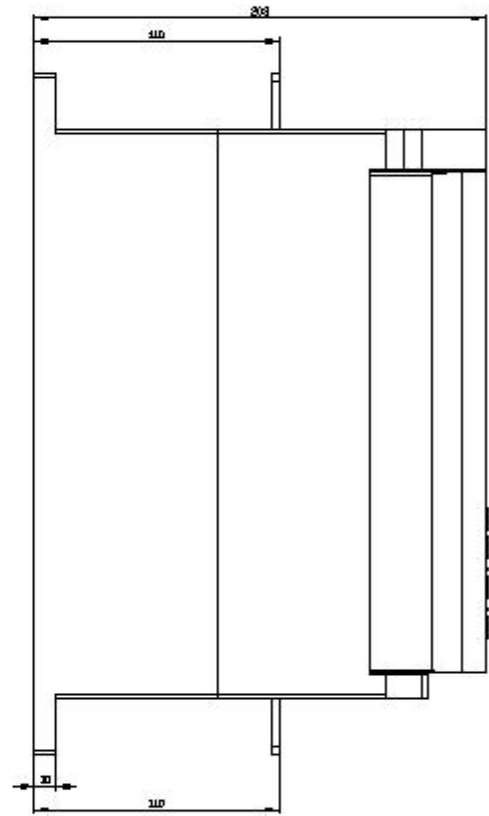
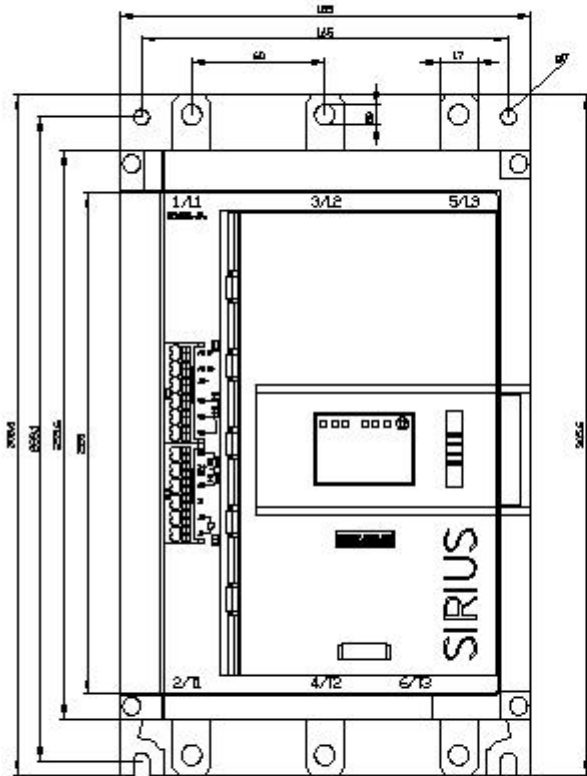

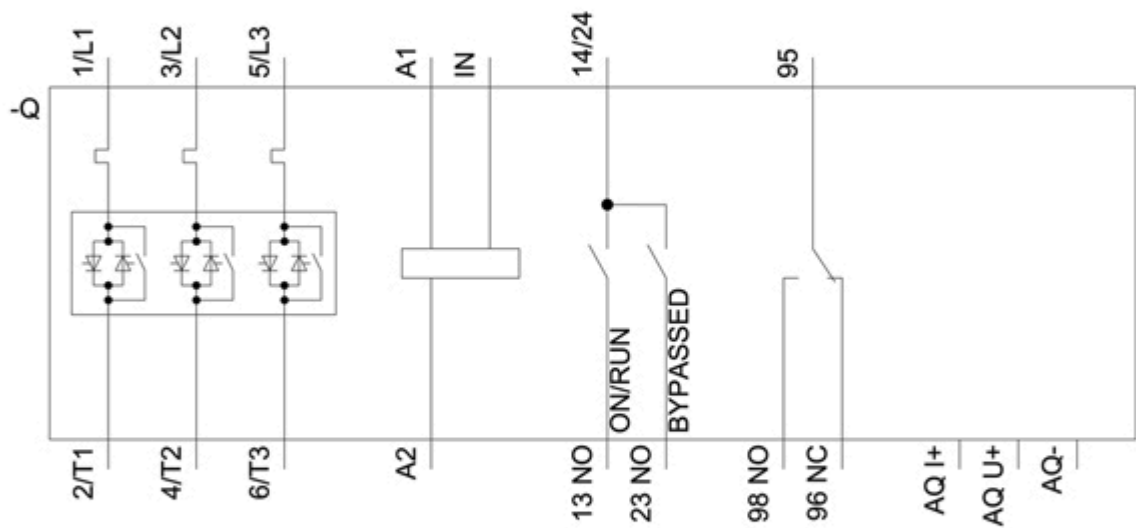

last modified:

12/15/2020 