

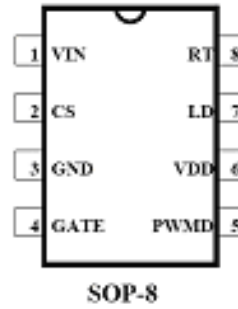

TB99 LED Driver

Features

- >90% Efficiency
- 8V to 450V input range
- Constant current LED driver
- Applications from a few mA to more than 1A Output
- LED string from one to hundreds of diodes
- PWM Low-Frequency Dimming via Enable pin
- Input Voltage Surge ratings up to 450V



Applications

- DC/DC or AC/DC LED Driver applications
- RGB backlighting LED Driver
- Backlighting of Flat Panel Displays
- General purpose constant current source
- Signage and Decorative LED Lighting
- Automotive
- Chargers

Description

The TB99 is a PWM high-efficiency LED driver control IC. It allows efficient operation of High Brightness (HB) LEDs from voltage sources ranging from $8V_{DC}$ up to $450V_{DC}$. The TB99 controls an external MOSFET at fixed switching frequency up to 500 kHz. The frequency can be programmed using a single resistor. The LED string is driven at constant current rather than constant voltage, thus providing constant light output and enhanced reliability. The output current can be programmed between a few milliamps and up to more than 1.0A

Absolute Maximum Ratings

V_{IN} to GND	-0.5V to +470V
CS.....	-0.3V to $V_{DD} + 0.3V$
LD, PWM_D to GND.....	-0.3V to $(V_{DD} - 0.3V)$
GATE to GND.....	-0.3V to $(V_{DD} + 0.3V)$
V_{DDMAX}	13.5V
ESD Capability, all pads except Pad 1 (V_{IN}) and Pad 7, 8 (V_{DD})	2.0KV
Maximum Voltage on Pad 1 (V_{IN}) and Pad 7, 8 (V_{DD})	470V
Continuous Power Dissipation($T_A = +25^\circ C$) (Note 1)	
8 Pin SOP (derate 6.3mW/ $^\circ C$ above +25 $^\circ C$).....	630mW
Operating Temperature Range	-40 $^\circ C$ to +85 $^\circ C$
Junction Temperature.....	+125 $^\circ C$
Storage Temperature Range	-65 $^\circ C$ to +150 $^\circ C$

Stresses beyond those listed under “Absolute Maximum Ratings” may cause permanent damage to the device. These are stress ratings only, and functional operation of the device at these or any other conditions beyond those indicated in the operational sections of the specifications is not implied. Exposure to absolute maximum rating conditions for extended periods may affect device reliability.



TB99 LED Driver

Specifications ($T_A = 25^\circ\text{C}$ unless noted otherwise)

Symbol	Description	Min	Typ	Max	Units	Conditions
V_{INDC}	Input DC supply voltage range	8.0		450	V	DC input voltage
I_{INsd}	Shut-Down mode supply current		0.5	1.0	mA	Pin PWM_D to GND, $V_{IN} = 8\text{V}$
V_{DD}	Internally regulated voltage	7.0	7.5	8.0	V	$V_{IN} = 8\text{--}450\text{V}$, $I_{DD(ext)} = 0$, pin Gate open
V_{DDmax}	Maximal pin V_{DD} voltage			13.5	V	When an external voltage applied to pin V_{DD}
$I_{DD(ext)}$	V_{DD} current available for external circuitry ¹			1.0	mA	$V_{IN} = 8\text{--}100\text{V}$
UVLO	V_{DD} under voltage lockout threshold	6.45	6.7	6.95	V	V_{IN} rising
ΔUVLO	V_{DD} under voltage lockout hysteresis		500		mV	V_{IN} falling
$V_{EN(lo)}$	Pin PWM_D input low voltage			1.0	V	$V_{IN} = 8\text{--}450\text{V}$
$V_{EN(hi)}$	Pin PWM_D input high voltage	2.4			V	$V_{IN} = 8\text{--}450\text{V}$
RLN	Pin PWM_D pull-down resistance	50	100	150	k Ω	$V_{EN} = 5\text{V}$
$V_{CS(hi)}$	Current sense pull-in threshold voltage	237	262	287	mV	@ $T_A = -40^\circ\text{C}$ to $+85^\circ\text{C}$
$V_{GATE(hi)}$	GATE high output voltage	$V_{DD} - 0.3$		V_{DD}	V	$I_{OUT} = -10\text{mA}$
$V_{GATE(lo)}$	GATE low output voltage	0		0.3	V	$I_{OUT} = 10\text{mA}$
fosc	Oscillator frequency	20 80	25 100	30 120	kHz	Rosc = 1.00 M Ω Rosc = 226 k Ω
D_{MAXht}	Maximum Oscillator PWM Duty Cycle			100	%	$F_{PWMhf} = 25\text{kHz}$, at GATE, CS to GND
V_{LD}	Linear Dimming pin voltage range	0		250	mV	@ $T_A = <85^\circ\text{C}$, $V_{IN} = 12\text{V}$
T_{BLANK}	Current sense blanking interval	150	215	280	ns	$V_{CS} = 0.55V_{LD}$, $V_{LD} = V_{DD}$
t_{DELAY}	Delay from CS trip to GATE lo			300	ns	$V_{IN} = 12\text{V}$, $V_{LD} = 0.15$, $V_{CS} = 0$ to 0.22V after T_{BLANK}
t_{RISE}	GATE output rise time ²		30	50	ns	$C_{GATE} = 500\text{pF}$, 10% to 90% V_{GATE}
t_{FALL}	GATE output fall time ²		30	50	ns	$C_{GATE} = 500\text{pF}$, 90% to 10% V_{GATE}

note¹ Also limited by package power dissipation limit, whichever is lower,

AC/DC Off-Line Applications

The TB99 is a low-cost off-line buck or boost converter control IC specifically designed for driving multi-LED strings or arrays. It can be operated from either universal AC line or any DC voltage between 8–450V. Optionally, a passive power factor correction circuit can be used in order to pass the AC harmonic limits set by EN 61000-3-2 Class C for lighting equipment having input power less than 25W. The TB99 can drive up to hundreds of High-Brightness (HB) LEDs or multiple strings of HB LEDs. The LED arrays can be configured as a series or series/parallel connection. The TB99 regulates constant current that ensures controlled brightness and spectrum of the LEDs and extends their lifetime. The TB99 features an enable pin (PWM_D) that allows PWM control of brightness.

The TB99 can also control brightness of LEDs by programming continuous output current of the LED driver (so-called linear dimming) when a control voltage is applied to the LD pin.

The TB99 is offered in a standard 8-pin SOIC package. It is also available in a high voltage rated SO-16 package for applications that require V_{IN} greater than 250V.

The TB99 includes an internal high-voltage linear regulator that powers all internal circuits and can also serve as a bias supply for low voltage external circuitry.



TB99 LED Driver

LED Driver Operation

The TB99 can control all basic types of converters, isolated or non-isolated, operating in continuous or discontinuous conduction mode. When the gate signal enhances the external power MOSFET, the LED driver stores the input energy in an inductor or in the primary inductance of a transformer and, depending on the converter type, may partially deliver the energy directly to LEDs. The energy stored in the magnetic component is further delivered to the output during the off-cycle of the power MOSFET producing current through the string of LEDs (Flyback mode of operation).

When the voltage at the V_{DD} pin exceeds the UVLO threshold the gate drive is enabled. The output current is controlled by means of limiting peak current in the external power MOSFET. A current sense resistor is connected in series with the source terminal of the MOSFET. The voltage from the sense resistor is applied to the CS pin of the TB99. When the voltage at CS pin exceeds a peak current sense voltage threshold, the gate drive signal terminates, and the power MOSFET turns off. The threshold is internally set to 250mV, or it can be programmed externally by applying voltage to the LD pin. When soft start is required, a capacitor can be connected to the LD pin to allow this voltage to ramp at a desired rate, therefore, assuring that output current of the LED ramps gradually.

Optionally, a simple passive power factor correction circuit, consisting of 3 diodes and 2 capacitors, can be added as shown in the typical application circuit diagram of Figure 1.

Supply Current

A current of 1mA is needed to start the TB99. As shown in the block diagram on page 3, this current is Internally generated in the TB99 without using bulky startup resistors typically required in the offline applications. Moreover, in many applications the TB99 can be continuously powered using its internal linear regulator that provides a regulated voltage of 7.5V for all internal circuits.

Setting Light Output

When the buck converter topology of Figure 2 is selected, the peak CS voltage is a good representation of the average current in the LED. However, there is a certain error associated with this current sensing method that needs to be accounted for. This error is introduced by the difference between the peak and the average current in the inductor. For example if the peak-to-peak ripple current in the inductor is 150mA, to get a 500mA LED current, the sense resistor should be $262\text{mV}/(500\text{mA} + 0.5 \cdot 150\text{mA}) = 0.46\Omega$.

Dimming

Dimming can be accomplished in two ways, separately or combined, depending on the application. Light output of the LED can be controlled either by linear change of its current, or by switching the current on and off while maintaining it constant. The second dimming method (so-called PWM dimming) controls the LED brightness by varying the duty ratio of the output current.

The linear dimming can be implemented by applying a control voltage from 0 to 250mV to the LD pin. This control voltage overrides the internally set 250mV threshold level of the CS pin and programs the output current accordingly. For example, a potentiometer connected between V_{DD} and ground can program the control voltage at the CS pin. Applying a control voltage higher than 250mV will not change the output current setting. When higher current is desired, select a smaller sense resistor.

The PWM dimming scheme can be implemented by applying an external PWM signal to the PWM_D pin. The PWM signal can be generated by a microcontroller or a pulse generator with a duty cycle proportional to the amount of desired light output. This signal enables and disables the converter modulating the LED current in the PWM fashion. In this mode, LED current can be in one of the two states: zero or the nominal current set by the current sense resistor. It is not possible to use this method to achieve average brightness levels higher than the one set by the current sense threshold level of the TB99. By using the PWM control method of the TB99, the light output can be adjusted between zero and 100%. The accuracy of the PWM dimming method is limited only by the minimum gate pulse width, which is a fraction of a percent of the low frequency duty cycle. Some of the typical waveforms illustrating the PWM dimming method used with the application circuit on page 7 are given below. CH1



TB99 LED Driver

shows the MOSFET Drain voltage, CH2 is the PWM signal to pin PWM_D and CH4 is the current in the LED string.

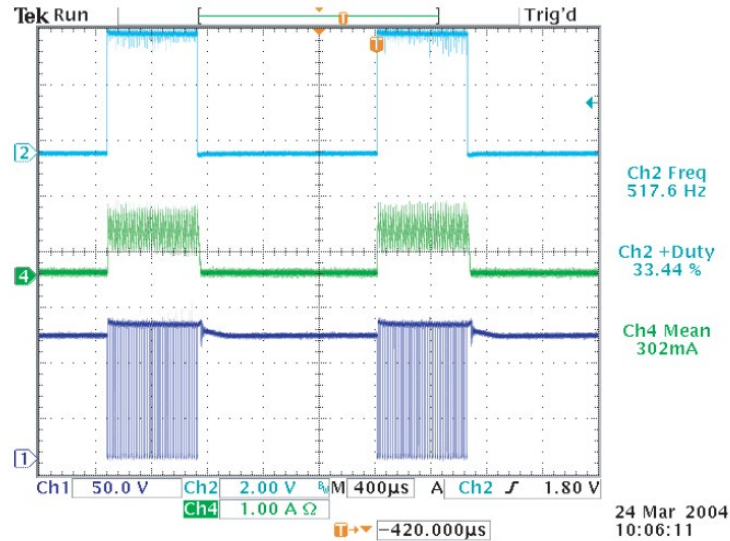

33% PWM Ratio at 500Hz Dimming

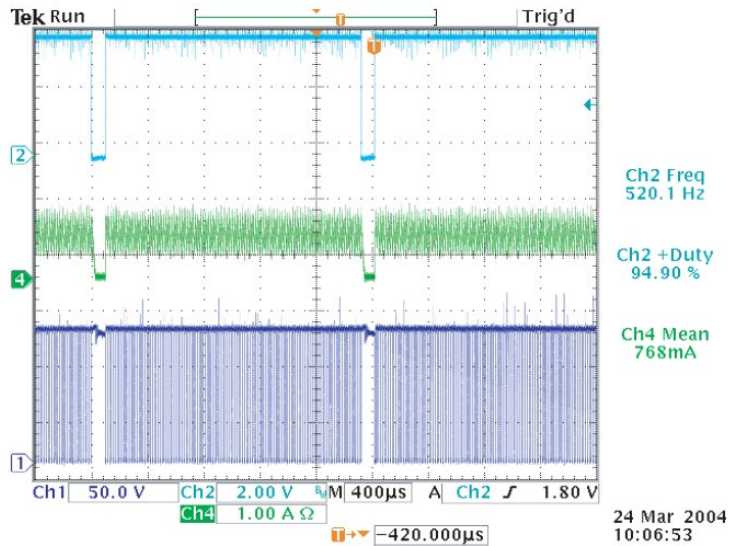

95% PWM Ratio at 500Hz Dimming



TB99 LED Driver

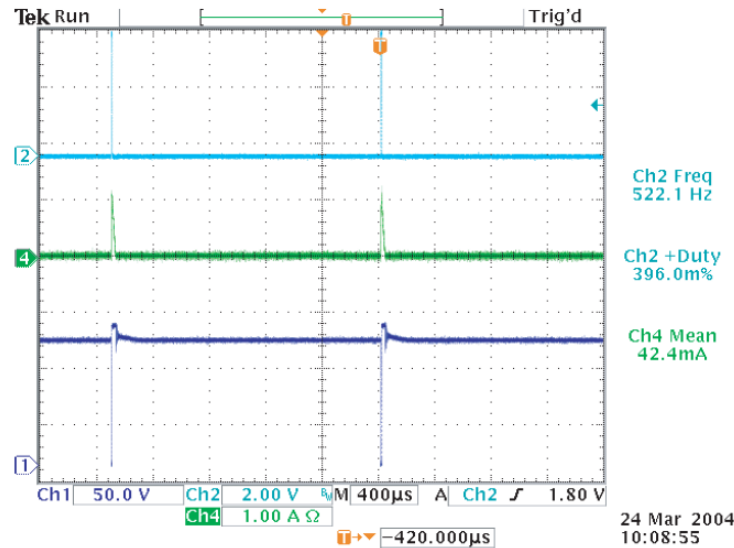

0.4% PWM Ratio at 500Hz Dimming

Programming Operating Frequency

The operating frequency of the oscillator is programmed between 25 and 300kHz using an external resistor connected to the R_T pin :

$$F_{osc} = 25000 / (R_T [k\Omega] + 22) [kHz]$$

Power Factor Correction

When the input power to the LED driver does not exceed 25W, a simple passive power factor correction circuit can be added to the TB99 typical application circuit on page 7 in order to pass the AC line harmonic limits of the EN61000-3-2 standard for Class C equipment. The typical application circuit diagram shows how this can be done without affecting the rest of the circuit significantly. A simple circuit consisting of 3 diodes and 2 capacitors is added across the rectified AC line input to improve the line current harmonic distortion and to achieve a power factor greater than 0.85.

Inductor Design

Referring to the typical application circuit on page 7 the value can be calculated from the desired peak-to-peak LED ripple current in the inductor. Typically, such ripple current is selected to be 30% of the nominal LED current. In the example given here, the nominal current I_{LED} is 350mA. The next step is determining the total voltage drop across the LED string. For example, when the string consists of 10 High-Brightness LEDs and each diode has a forward voltage drop of 3.0V at its nominal current; the total LED voltage V_{LEDs} is 30V.

Knowing the nominal rectified input voltage $V_{IN} = 120V * 1.41 = 169V$, the switching duty ratio can be determined, as : $D = V_{LEDs} / V_{IN} = 30 / 169 = 0.177$

Then, given the switching frequency, in this example $f_{osc} = 50KHz$, the required on-time of the MOSFET transistor can be calculated :

$$T_{ON} = D / f_{osc} = 3.5 \text{ microsecond}$$

The required value of the inductor is given by :

$$L = (V_{IN} - V_{LEDs}) * T_{ON} / (0.3 * I_{LED}) = 4.6mH$$



TB99 LED Driver

Input Bulk Capacitor

An input filter capacitor should be designed to hold the rectified AC voltage above twice the LED string voltage throughout the AC line cycle. Assuming 15% relative voltage ripple across the capacitor, a simplified formula for the minimum value of the bulk input capacitor is given by :

$$C_{MIN} = I_{LED} * V_{LEDS} * 0.06 / V_{IN}^2$$

$C_{MIN} = 22 \mu F$, a value $22 \mu F / 250V$ can be used.

A passive PFC circuit at the input requires using two series connected capacitors at the place of calculated C_{MIN} . Each of these identical capacitors should be rated for 1/2 of the input voltage and have twice as much capacitance.

Enable

The TB99 can be turned off by pulling the PWM_D pin to ground. When disabled, the TB99 draws quiescent current of less than 1mA.

Output Open Circuit Protection

When the buck topology is used, and the LED is connected in series with the inductor, there is no need for any protection against an open circuit condition in the LED string. Open LED connection means no switching and can be continuous.

DC/DC Low Voltage Applications

Buck Converter Operation

The buck power conversion topology can be used when the LED string voltage is needed to be lower than the input supply voltage. The design procedure for a buck LED driver outlined in the previous chapters can be applied to the low voltage LED drivers as well. However, the designer must keep in mind that the input voltage must be maintained higher than 2 times the forward voltage drop across the LEDs. This limitation is related to the output current instability that may develop when the TB99 buck converter operates at a duty cycle greater than 0.5. This instability reveals itself as an oscillation of the output current at a sub-harmonic of the switching frequency.

Block Diagram

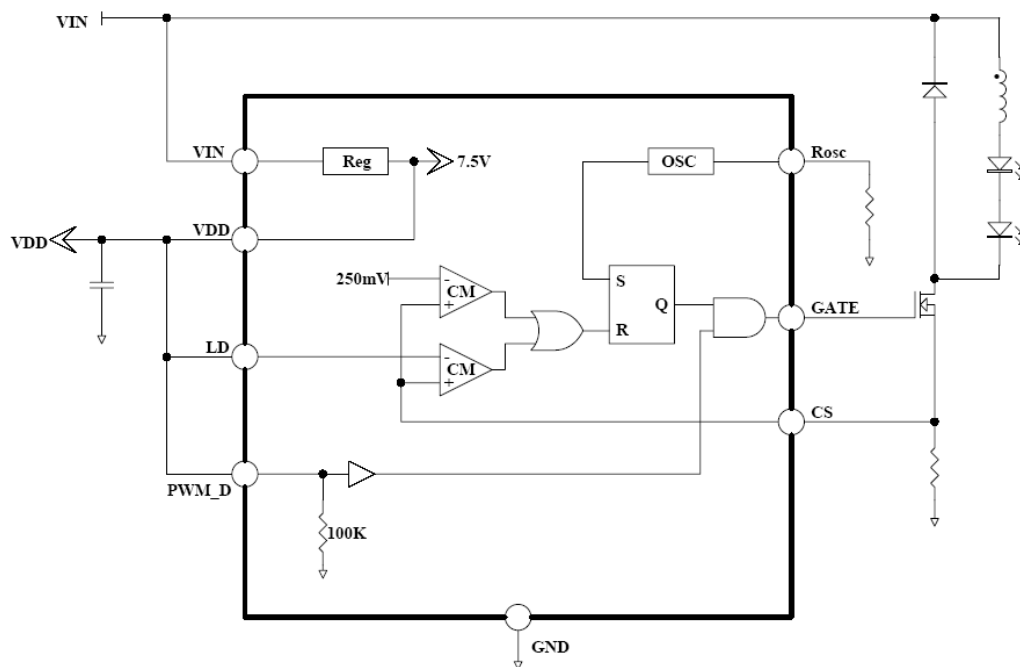



TB99 LED Driver

Package Information

SOP-8

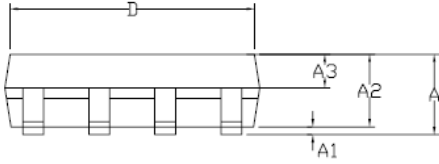

SYMBOL	MILLIMETER		
	MIN	NOM	MAX
A	—	—	1.75
A1	0.10	—	0.225
A2	1.30	1.40	1.50
A3	0.60	0.65	0.70
b	0.39	—	0.47
b1	0.38	0.41	0.44
c	0.20	—	0.24
c1	0.19	0.20	0.21
D	4.80	4.90	5.00
E	5.80	6.00	6.20
E1	3.80	3.90	4.00
e	1.27 BSC		
h	0.25	—	0.50
L	0.50	—	0.80
L1	1.05 REF		
ø	0	—	8'

