

REV

A0



产品规格书

Specification Confirmation

客户(CUSTOMER): _____

型号(MODEL NO.): **DS-S003M-01**

5g 铜齿数字舵机

在您下单采购本产品之前请您阅读本规格书并在下列承认栏内签字回传!

Please detail check and sign it back before order this product!

客户承认栏 Custom Confirmation

承认 Prepared	审核 Checked	批准 Approval

本公司承认栏 DS Confirmation

承认 Prepared	审核 Checked	批准 Approval
陆权才	孙倩	

修改记录 Revise record

REV	记录 Record	日期 Date
A0	初版发行	2023.7.22

	Item	Specification	Remarks	
1	Operating Voltage 工作电压	4.8-6V DC		
2	Standby Current 静态电流	≤40 mA		
3	Consumption Current* (No Load) 空载工作电流	4.8V	≅ 100mA	
		6V	≅ 110mA	
4	Stall Current 堵转电流	4.8V	≅ 800mA	
		6V	≅ 950mA	
5	Rated Torque 额定力矩	4.8V	≥0.5kgf·cm	
		6V	≥0.6kgf·cm	
6	Max. Torque* 最大扭矩	4.8V	≥1.2 kgf·cm	
		6V	≥1.4 kgf·cm	
7	No Load Speed* 空载速度	4.8V	≅ 0.08sec/60°	
		6V	≅ 0.07sec/60°	
8	Rotating Direction 旋转方向	CCW (1000→2000us)		
9	Pulse Width Range 脉冲宽度范围	1000~2000us		
10	Neutral Position 中位	1500us		
11	Operating Travel Angle 操作角度	90°±10° (1000~2000us)		
12	Max. Operating Travel Angle 最大可操作角度	180°±10° (500~2500us)		
13	Mechanical Limit Angle 机械极限角度	360°		
14	Left & Right Travelling Angle Deviation 左右角度差	≤ 6°		
15	Centering deviation 回中差	≤ 3°		
16	Back Lash* 虚位	≤ 1°		
17	Dead Band Width 死区宽度	≤ 5 us		
18	Operating Temperature Range 工作温度	-10℃ ~ +50℃		
19	Storage Temperature Range 储存温度	-20℃~+60℃		
20	Operating Humidity Range 工作湿度	≤ 90%RH		
21	Storage Humidity Range 储存湿度	≤ 90%RH		
22	Weight 重量	/		
23	Case Material 外壳材质	ABS		
24	Gear Set Material 齿轮材质	Metal 金属齿轮		
25	Reduction ratio 减速比	1/294		
26	Motor Type 马达类型	coreless motor 空心杯马达		
27	VR Parameter 电位器参数	Type 类型	Carbon-Film Potentiometer	
		Angle 角度	210°	
		Life 寿命	100 0000Cycles Min	
28	Cable 电缆	Material 材质	Φ0.8,16 芯 PVC	
		Length 长度	200±5mm (外露不含插头)	
29	Horn Gear Spline 摇臂齿数	28T/Φ3.90mm		
30	Horn Gear Type 摇臂类型	见附图		
31	Rocker Arm Screw 摇臂螺丝	PM2.0x3.5mm 镀镍		
32	Connector 连接器	Type 类型	JR/3 拼/棕红橙/2.54mm	
		Pin Assignment 引脚定义	1 棕色	GND
			2 红色	Vcc
3 橙色	Signal / PWM			
33	Communication Interface 通信协议	PWM	Signal Voltage: V	HIGH : Min.2.0V , Max. Vcc LOW : Min,0.0V , Max.0.45V
			Frame Rate: T	3.0 ~ 30ms (Default 20ms)
			Left/Center/Right: Td	2000/1500/1000us
			Resolution	-
34	Amplifier Type 放大器类型	Digital		



Signal Voltage: V	HIGH : Min.2.0V , Max. Vcc LOW : Min,0.0V , Max.0.45V
Frame Rate: T	3.0 ~ 30ms (Default 20ms)
Left/Center/Right: Td	2000/1500/1000us
Resolution	-

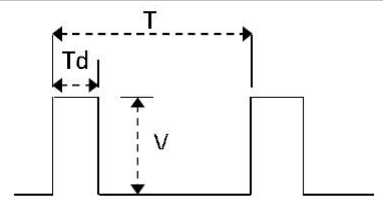

Outside Dimension: (Unit: mm)

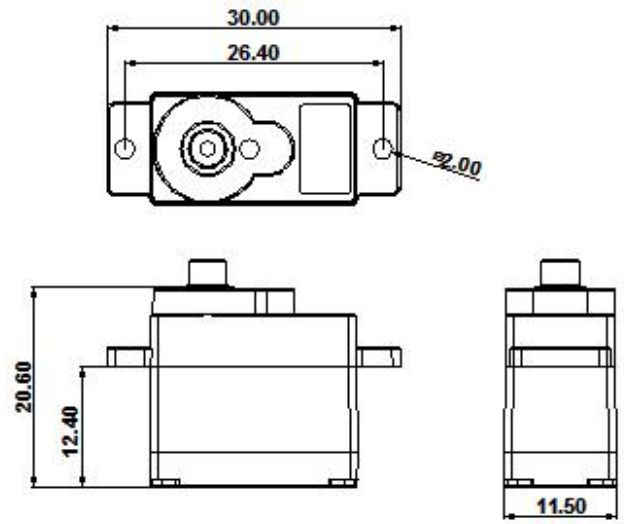

Picture 1-1

Accessories:



Picture 1-2

Electrical Schematic Diagram :

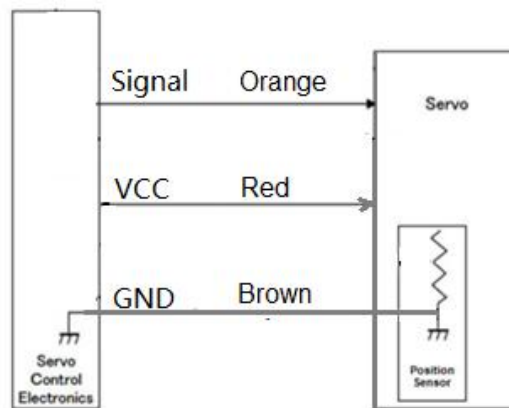

Picture 1-2

Remarks:

* At 23±5°C (Initial Performance Data)

(抽样计划 Sample Plan:

外观 Appearance: MIL-STD-105E AQL II (MA=0.65/MI=1.0)

尺寸及功能 Dimension and Function: MIL-STD-105E AQL I (MA=0.65/MI=1.0))