

COMPONENT SPECIFICATION
MATERIAL = BERYLLIUM COPPER, 0.15mm
FINISH = 0.10µm - 0.17µm GOLD OVER
1.0µm MIN NICKEL

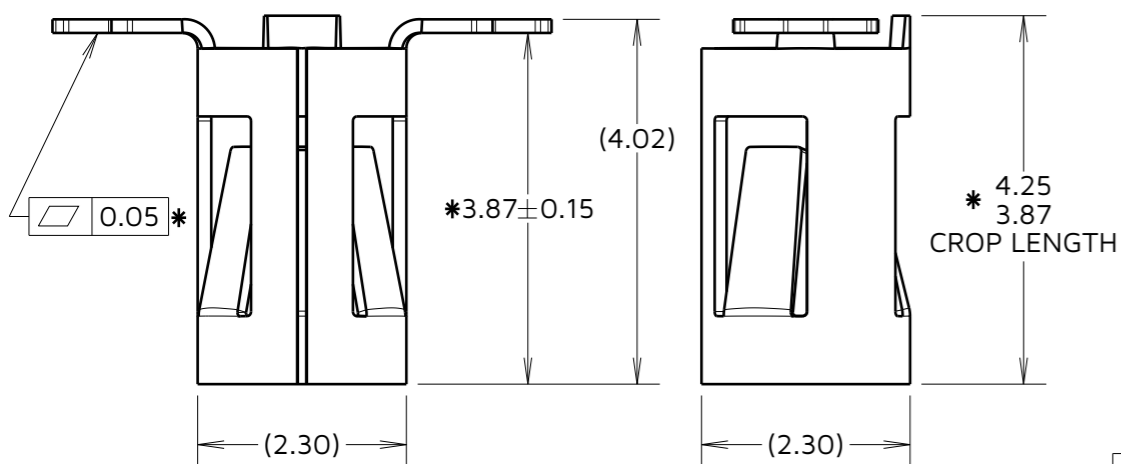

- NOTES:
- DIMENSIONS AND NOTES MARKED * ARE CRITICAL AND MUST BE CHECKED IN ACCORDANCE WITH WORK INSTRUCTION WI-64.
 - QUANTITY OF COMPONENTS PER REEL = 1400.
 - TAPE MUST HAVE A 400mm LEADER AND A 160mm TRAILER.
 - PRODUCT IS TO BE TAPE AND REELED IN GENERAL ACCORDANCE WITH EIA-481-2 (ELECTRONICS INDUSTRIES ASSOCIATION).
 - MAX PERMISSIBLE BURR AFTER CROP IS 0.05mm AND SHOULD BE ON NOTED EDGE.
 - EACH REEL MUST BE CLEARLY LABELLED WITH PART No. QUANTITY PER REEL AND BATCH No.
 - COMPONENTS MUST BE ORIENTATED WITH CROP TOWARDS THE SPROCKET HOLES OF THE TAPE.
 - CENTRE OF EACH WING TO BE MEASURED TO THE CENTRE OF Ø 2.00 INSCRIBED DIAMETER. DISTANCE IN Y = ±0.15mm MAX.

RTP	6	22.06.23	32401
RA	5	11.03.20	30020
RTP	4	22.03.19	21438
SB	3	30.08.18	21150
FM	2	09.04.18	21042
SB	1	14.06.17	20664
SB	A	14.03.17	20486

NAME	ISS.	DATE	CN/CO
APPROVED:		R.PORTLOCK	
CHECKED:		A.BOXALL	
DRAWN:		S.BENNETT	
ASSEMBLY DRG:			
PART WEIGHT:		MAT'L USAGE:	

HARWIN

www.harwin.com

TOLERANCES
X. = ±1mm
X.X = ±0.50mm
X.XX = ±0.10mm
X.XXX = ±0.01mm
ANGLES = ±5°
UNLESS STATED

THIS DRAWING AND ANY INFORMATION OR DESCRIPTIVE MATTER SET OUT HEREON ARE CONFIDENTIAL AND COPYRIGHT PROPERTY OF THE HARWIN GROUP AND MUST NOT BE DISCLOSED, LOANED, COPIED OR USED FOR MANUFACTURING, TENDERING OR FOR ANY OTHER PURPOSE WITHOUT THEIR WRITTEN PERMISSION.

MATERIAL:
SEE ABOVE
FINISH: SEE ABOVE
S/AREA: mm²

TITLE: SYCAMORE CONTACT
Ø 1.50mm BOTTOM ENTRY
SOCKET IN TAPE & REEL

DRAWING NUMBER:
S9121-45R

SHT
1 OF 2