

REV. 版本

01



Specification Confirmation
产品规格书

CUSTOMER (客户): _____

MODEL NO. (型号): _____ DS-S007M

MODEL NAME. (名称): _____ 21克铜齿舵机

Please detail check and sign it back before order this product!
在您下单采购本产品之前请您阅读本规格书并在下列承认栏内签字回传!

DS Confirmation 德晟承认栏

Prepared 承认	Checked 审核	Approval 批准
李哲	赖正礼	

Custom Confirmation 客户承认栏

Prepared 承认	Checked 审核	Approval 批准

Revise record 修改记录

REV. 版本	Record detail 记录细节	Date日期
00	初始发行	2020/2/18

东莞市德晟智能科技有限公司

No	Item 项目	Specification 规格	Remarks 备注		
1	Operating Voltage 工作电压范围	4.8-6V DC			
2	Standby Current 静态电流	10mA at 4.8V (STD. 标准值)			
3	No Load Current* 空载电流	≤200mA at 4.8V (STD. 参考值)			
		≤210mA at 6.0V (STD. 标准值)			
4	No Load Speed* 空载速度	≤0.10 sec/60° at 4.8V (STD. 参考值)			
		≤0.12 sec/60° at 6.0V (STD. 标准值)			
5	Rated Torque 额定扭矩	≥1.0kgf·cm at 4.8V (STD. 参考值)			
		≥1.2kgf·cm at 6.0V (STD. 标准值)			
6	Stall Current 堵转电流	≤1.5A at 4.8V (STD. 参考值)			
		≤1.8A at 6.0V (STD. 标准值)			
7	Stall Torque* 堵转扭矩	≥3.8kgf·cm at 4.8V (STD. 参考值)	扭力磅测试		
		≥4.2kgf·cm at 6.0V (STD. 标准值)			
8	Rotating Direction* 旋转方向	CCW (1000→2000 μs) 逆时针	俯视输出轴端方向		
9	Pulse Width Range 信号宽度范围	500~2500 μs			
10	Neutral Position 中位	1500 μs			
11	Operating Travel Angle 操作角度	90° ±10° (1000~2000 μs)			
12	Mechanical Limit Angle 机械极限角度	210°			
13	Angle deviation 角度精度	≤ 1°	即回中差		
14	L&R Angle deviation 左右两边角度精	≤ 5°	即边角差		
15	Back Lash* 虚位	≤ 1°			
16	Dead Band Width 死区宽度	≤ 5 μs	最小启动信号宽度		
17	Operating Temperature Range 工作环境	-10℃~+50℃; ≤90%RH			
18	Storage Temperature Range 储存温度	-20℃~+60℃; ≤90%RH			
19	Weight 重量	21 ± 1g			
20	Case Material 外壳材质	PA			
21	Gear Set Material 齿轮材质	Metal 金属齿轮			
22	Motor Type 马达类型	Core motor 铁芯马达			
23	Angle Sensor 角度传感器	Type 类型	Carbon Film Potentiometer 碳膜电位器		
		Angle 角度	220		
		Life 寿命	500,000 Cycles (Min.)		
24	Connector and Cable 连接器和电缆	Type 类型	JR		
		Material 材质	PVC		
		Length 线长度	210 ± 5mm (外露不含插头)		
		Pin Assignment 引脚定义	1	Brown 棕	GND
			2	Red 红	Vcc
3	Orange 橙		Signal / PWM		



Outside Dimension外观尺寸:(Unit单位: mm)

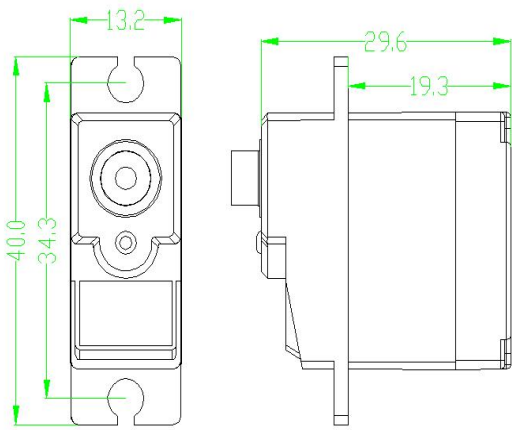

Accessories配件:

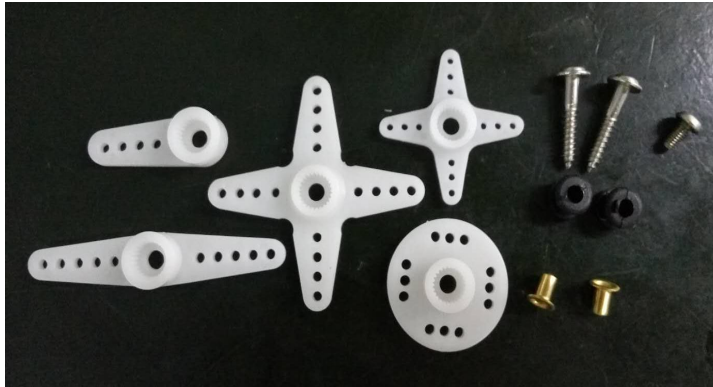

Electrical Schematic Diagram 电路简图:

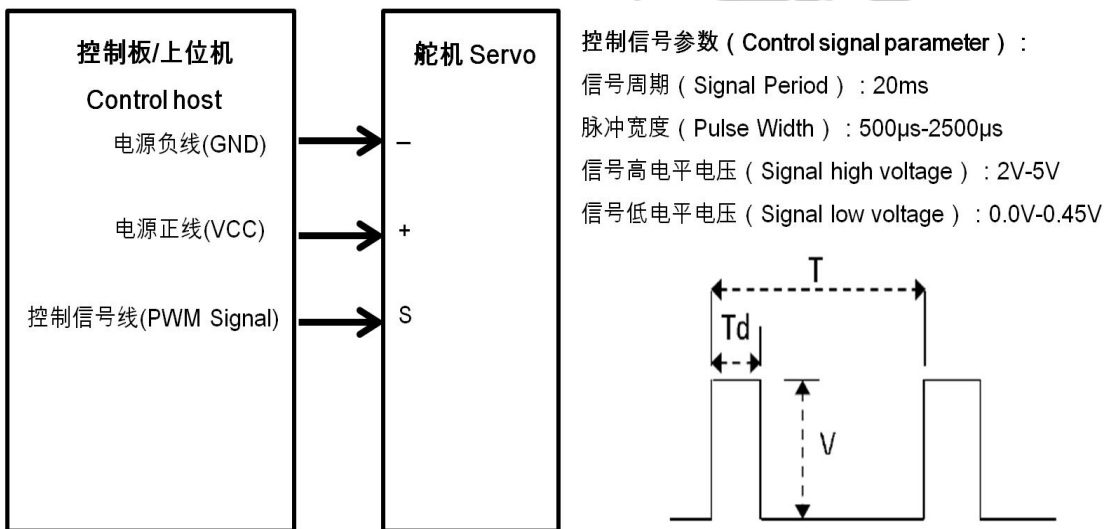

Remarks 备注:

- * Initial Performance Data By DS Servo Tester At 23 \pm 5 $^{\circ}$ C.
- * 起始性能数据是在23 \pm 5 $^{\circ}$ C下通过德晟标准舵机测试架测试的数据。”

(Sample Plan抽样计划:

Appearance 外观: MIL-STD-105E AQL II (MA=0.65/MI=1.0)

Dimension and Function 尺寸及功能: MIL-STD-105E AQL I (MA=0.65/MI=1.0))