

REV

A1



产品规格书

Specification Confirmation

客户(CUSTOMER): 德晟标准版

型号(MODEL NO.): DS-H003-C 矮身空心杯舵机

在您下单采购本产品之前请您阅读本规格书并在下列承认栏内签字回传!

Please detail check and sign it back before order this product!

客户承认栏 Custom Confirmation

承认 Prepared	审核 Checked	批准 Approval

本公司承认栏 DS Confirmation

承认 Prepared	审核 Checked	批准 Approval
李哲	赖正礼	

修改记录 Revise record

REV	记录 Record	日期 Date
A/0	初版发行	2020.07.11

	Item	Specification	Remarks
1	Operating Voltage 工作电压	6.0~7.4V DC	
2	Standby Current 静态电流	≤20mA	
3	Consumption Current* (No Load) 空载工作电流	6.0V	≤230 mA
		7.4V	≤240 mA
4	Stall Current 堵转电流	6.0V	≤3.2A
		7.4V	≤4.0 A
5	Max. Torque* 最大扭矩	6.0V	≥13 Kgf.cm
		7.4V	≥16 Kgf.cm
6	No Load Speed* 空载速度	6.0V	≤0.09 Sec/60°
		7.4V	≤0.08Sec/60°
7	Rotating Direction 旋转方向	(2000us→1000us) 顺时针及正向	
8	Pulse Width Range 脉冲宽度范围	500~2500 us	
9	Neutral Position 中位	1500 us	
10	Operating Travel Angle 操作角度	90° ±10°(1000~2000 us)	
11	Max. Operating Travel Angle 最大可操作角度	180°±10° (500~2500us)	
12	Mechanical Limit Angle 机械极限角度	360°	
13	Left & Right Travelling Angle Deviation 左右角度差	≤ 5°	
14	Centering deviation 回中差	≤ 1°	
15	Back Lash* 虚位	≤ 1°	
16	Dead Band Width 死区宽度	≤ 4 us	
17	Operating Temperature Range 工作温度	-10℃~+50℃	
18	Storage Temperature Range 储存温度	-20℃~+60℃	
19	Operating Humidity Range 工作湿度	≤ 90%RH	
20	Storage Humidity Range 储存湿度	≤ 90%RH	
21	Weight 重量	58 ± 0.5g	
22	Case Material 外壳材质	金属	
23	Gear Set Material 齿轮材质	金属齿轮	
24	Reduction ratio 减速比	/	
25	Motor Type 马达类型	空心杯马达	
26	Position Detect System 位置检测系统	Type 类型	Carbon-Film Potentiometer VR
		Angle 角度	330°(无限位)
		Life 寿命	100 0000Cycles Min
27	Cable 电缆	Type 类型	#60 PVC
		Length 长度	350±5mm (不含插头)
28	Horn Gear Spline 摇臂齿数	25T/Φ5.9mm	
29	Horn Gear Type 摇臂类型	见附图	
30	Rocker Arm Screw 摇臂螺丝	PMΦ3X5/镀镍	
31	Connector 连接器	Type 类型	Futaba2.54/3Pin/ 黑红白
		Pin Assignment 引脚定义	1 黑 GND
			2 红 Vcc
3 白 Signal / PWM			



32	Communication Interface 通信协议	PWM	Signal Voltage: V	HIGH : Min,2.0V , Max. Vcc LOW : Min,0.0V , Max.0.45V
			Frame Rate: T	3.0~30ms (Default 20ms)
			Left/Center/Right: Td	2500/1500/500us
			Resolution	—



| 33 | Amplifier Type 放大器类型 | Digital | |

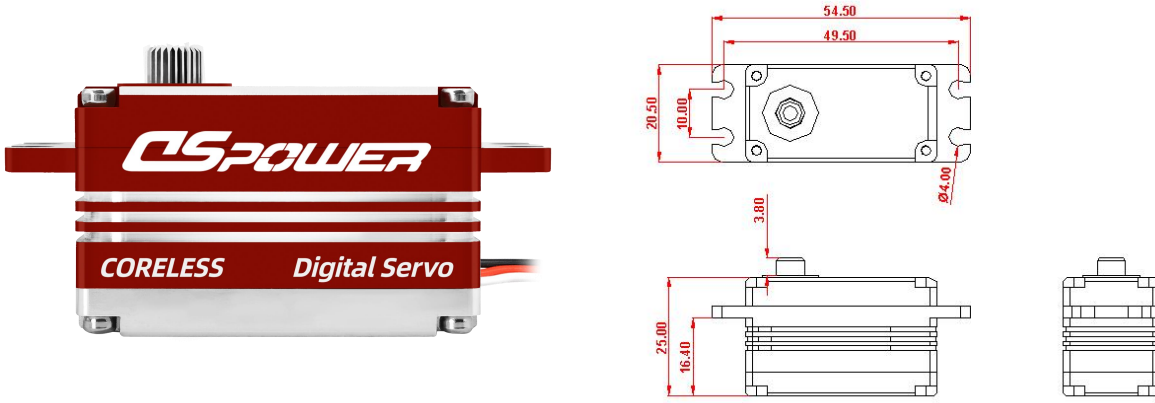

Picture 1-1



Picture 1-2

Electrical Schematic Diagram :

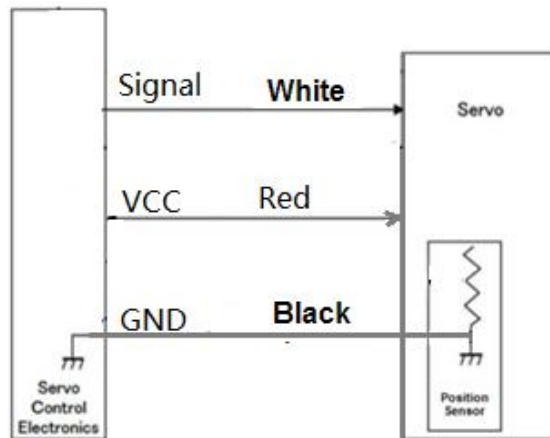

Picture 1-3

Remarks:

* At 23±5°C (Initial Performance Data)

(抽样计划Sample Plan:

外观Appearance: MIL-STD-105E AQL II (MA=0.65/MI=1.0)

尺寸及功能Dimension and Function: MIL-STD-105E AQL I (MA=0.65/MI=1.0))