

ABOV SEMICONDUCTOR Co., Ltd.
8-BIT MICROCONTROLLERS

MC96FT242

User's Manual (Ver. 1.3)



REVISION HISTORY

VERSION	COMMENT	DATE
0.1	First release.	2014-03-25
1.0	Configure option modified.	2014-07-09
1.1	Pin Assignment and dscription, block diagram, PWM, interrupt block diagram, IE & IE1 registers, and PCI modified. MC96FT242L(32-LQFP) inserted. 15. Flash Memory modified.	2014-08-29
1.2	Fix typo. KSMR Description modified.	2014-10-16
1.2a	Table 11-12 modified. (Examples of UBAUD Settings)	2014-12-22
1.2b	TMISR is removed.	2015-05-29
1.3	RSD Register description modified	2016-10-06

Published by ABOV Semiconductor
©2014 ABOV Semiconductor Co., Ltd. All rights reserved.

Additional information of this manual may be served by ABOV Semiconductor offices in Korea or Distributors.
ABOV Semiconductor reserves the right to make changes to any information here in at any time without notice.
The information, diagrams and other data in this manual are correct and reliable; however, ABOV Semiconductor is in no way responsible for any violations of patents or other rights of the third party generated by the use of this manual.

Table of Contents

REVISION HISTORY	2
Table of Contents	4
MC96FT242	9
1. Overview	9
1.1 Description	9
1.2 Features	9
1.3 Ordering Information	11
1.4 Development Tools	12
2. Block Diagram	14
3. Pin Assignment	15
4. Package Diagram	20
5. Pin Description	25
6. Port Structures	26
6.1 General Purpose I/O Port	26
7. Electrical Characteristics	27
7.1 Recommended Operating Conditions	27
7.2 Voltage Dropout Converter Characteristics	28
7.3 Power-On Reset Characteristics	28
7.4 Touch Switch Characteristics	29
7.5 Brown Out Detector Characteristics	29
7.6 Internal RC Oscillator Characteristics	30
7.7 Ring-Oscillator Characteristics	30
7.8 A/D Converter Characteristics	30
7.9 DC Characteristics	31
7.10 AC Characteristics	32
7.11 Typical Characteristics	33
8. Memory	34
8.1 Program Memory	34
8.2 Data Memory	36
8.3 XSFR	38
8.4 SFR Map	39
9. I/O Ports	42
9.1 I/O Ports	42
9.2 Port Register	42
9.3 P0, P1, P2, P3 Port	45
10. Interrupt Controller	49
10.1 Overview	49
10.2 Block Diagram	50
10.3 Interrupt Vector Table	51
10.4 Interrupt Sequence	52
10.5 Effective Timing after Controlling Interrupt bit	53
10.6 Multi Interrupt	53
10.7 Interrupt Enable Accept Timing	55
10.8 Interrupt Service Routine Address	55

10.9 Saving/Restore General-Purpose Registers.....	55
10.10 Interrupt Timing.....	56
10.11 Interrupt Register Overview.....	56
10.12 Interrupt Register Description.....	57
11. Peripheral Hardware	60
11.1 Clock Generator.....	60
11.2 BIT	63
11.3 WDT	65
11.4 Free Run Counter.....	68
11.5 Buzzer Driver.....	71
11.6 Timer/PWM.....	73
11.7 USART	83
11.8 I ² C.....	102
11.9 12-Bit A/D Converter	114
11.10 24-Channel Touch Switch.....	120
12. Power Down Operation	134
12.1 Overview.....	134
12.2 Peripheral Operation in IDLE/STOP Mode.....	134
12.3 IDLE mode	135
12.4 STOP mode.....	136
12.5 Release Operation of STOP1, 2 Mode.....	137
13. RESET	139
13.1 Overview.....	139
13.2 Reset Source	139
13.3 Block Diagram.....	139
13.4 RESET Noise Canceller.....	140
13.5 Power ON RESET	140
13.6 External RESETB Input.....	143
13.7 Brown Out Detector Processor	144
14. On-chip Debug System.....	147
14.1 Overview.....	147
14.2 Two-pin External Interface	148
15. Memory Programming.....	152
15.1 Overview.....	152
15.2 Flash Control and Status Register.....	152
15.3 Memory map.....	156
15.4 Serial In-System Program Mode.....	158
15.5 Parallel Mode.....	163
15.6 Mode Entrance Method of ISP and byte-parallel Mode.....	166
15.7 Security	167
16. Configure Option.....	168
16.1 Configure Option Control Register.....	168
17. APPENDIX	169

List of Figures

Figure 1-1 OCD Debugger and Pin Description	12
Figure 1-2 Single Programmer	13
Figure 1-3 Gang Programmer	13
Figure 2-1 MC96FT242 Block Diagram	14
Figure 3-1 MC96FT242 32 QFN Pin Assignment.....	15
Figure 3-2 MC96FT242 32 LQFP Pin Assignment.....	16
Figure 3-3 MC96FT242 32 SOP Pin Assignment	17
Figure 3-4 MC96FT202 28 SOP Pin Assignment	18
Figure 3-5 MC96FT162 24 SOP Pin Assignment	19
Figure 4-1 32 pin SOP Package	20
Figure 4-2 32 pin QFN Package	21
Figure 4-3 32 pin LQFP Package.....	22
Figure 4-4 28 pin SOP Package	23
Figure 4-5 24 pin SOP Package	24
Figure 6-1 General Purpose I/O Port	26
Figure 7-1 AC Timing	32
Figure 7-2 Output High Voltage (VOH).....	33
Figure 7-3 Output Low Voltage (VOL).....	33
Figure 7-4 Active Current (Normal, Idle, Sub).....	33
Figure 7-5 Stop Current (Stop1, Stop2).....	33
Figure 8-1 Program Memory	35
Figure 8-2 Data Memory Map	36
Figure 8-3 Low 128 bytes RAM.....	37
Figure 8-4 XDATA Memory Area	38
Figure 9-1 Debounce Function	43
Figure 9-2 Pin Change Interrupt Description.....	43
Figure 10-1 Interrupt Group Priority Level	49
Figure 10-2 Block Diagram of Interrupt.....	50
Figure 10-3 Interrupt Sequence Flow	52
Figure 10-4 Interrupt Enable Register Effective Timing	53
Figure 10-5 Execution of Multi Interrupt	53
Figure 10-6 Interrupt Response Timing Diagram.....	55
Figure 10-7 Correspondence between Vector Table Address and the Entry Address of ISR	55
Figure 10-8 Saving/Restore Process Diagram & Sample Source	55
Figure 10-9 Timing chart of Interrupt Acceptance and Interrupt Return Instruction.....	56
Figure 11-1 Clock Generator Block Diagram.....	60
Figure 11-2 BIT Block Diagram.....	63
Figure 11-3 WDT Block Diagram	65
Figure 11-4 WDT Interrupt Timing Waveform	67
Figure 11-5 Free Run Counter Block Diagram.....	68
Figure 11-6 Buzzer Driver Block Diagram.....	71

Figure 11-7 Timer x 16-bit Mode Block Diagram.....	73
Figure 11-8 Interrupt of Timer/Counter Mode	74
Figure 11-9 Operation Example of Timer/Event Counter Mode	74
Figure 11-10 Timer x 16bit Capture Mode.....	75
Figure 11-11 Input Capture Mode Operation of Timer 0, 1.....	76
Figure 11-12 Express Timer Overflow in Capture Mode	76
Figure 11-13 PWM Mode.....	77
Figure 11-14 Example of PWM Output Waveform.....	78
Figure 11-15 Example of PWM (16MHz).....	78
Figure 11-16 USART Block Diagram	84
Figure 11-17 Clock Generation Block Diagram	85
Figure 11-18 Synchronous Mode XCKn Timing	86
Figure 11-19 Frame Format.....	87
Figure 11-20 Start Bit Sampling.....	91
Figure 11-21 Sampling of Data and Parity Bit	92
Figure 11-22 Stop Bit Sampling and Next Start Bit Sampling	92
Figure 11-23 SPI Clock Formats when UCPHA=0	93
Figure 11-24 SPI Clock Formats when UCPHA=1	94
Figure 11-25 I ² C Block Diagram.....	102
Figure 11-26 Bit Transfer on the I ² C-Bus.....	103
Figure 11-27 START and STOP Condition.....	103
Figure 11-28 Data Transfer on the I ² C-Bus	104
Figure 11-29 Acknowledge on the I ² C-Bus.....	104
Figure 11-30 Clock Synchronization during Arbitration Procedure	105
Figure 11-31 Arbitration Procedure of Two Masters.....	105
Figure 11-32 ADC Block Diagram.....	114
Figure 11-33 A/D Analog Input Pin Connecting Capacitor.....	115
Figure 11-34 ADC Operation for Align Bit.....	115
Figure 11-35 Converter Operation Flow.....	116
Figure 11-36 24 Channels Touch Switch Block Diagram	121
Figure 11-37 User Programming Procedure	133
Figure 12-1 IDLE Mode Release Timing by PCI Interrupt	135
Figure 12-2 IDLE Mode Release Timing by RESETB	135
Figure 12-3 STOP Mode Release Timing by PCI Interrupt	136
Figure 12-4 STOP Mode Release Timing by RESETB	136
Figure 12-5 STOP1, 2 Mode Release Flow	137
Figure 13-1 RESET Block Diagram.....	139
Figure 13-2 Reset noise canceller time diagram	140
Figure 13-3 Fast VDD rising time	140
Figure 13-4 Internal RESET Release Timing On Power-Up.....	141
Figure 13-5 Configuration timing when Power-on.....	141
Figure 13-6 Boot Process Wave Form.....	142
Figure 13-7 Timing Diagram after RESET.....	143

Figure 13-8 Oscillator generating waveform example.....	143
Figure 13-9 Block Diagram of BOD	144
Figure 13-10 Internal Reset at the Power Fail Situation	144
Figure 13-11 Configuration Timing when BOD Reset	145
Figure 14-1 Block Diagram of On-chip Debug System.....	148
Figure 14-2 10-bit Transmission Packet	149
Figure 14-3 Data Transfer on the Twin Bus	149
Figure 14-4 Bit Transfer on the Serial Bus	150
Figure 14-5 Start and Stop Condition	150
Figure 14-6 Acknowledge on the Serial Bus	150
Figure 14-7 Clock Synchronization during Wait Procedure	151
Figure 14-8 Connection of Transmission.....	151
Figure 15-1 Flash Memory Map	156
Figure 15-2 Address Configuration of Flash Memory.....	157
Figure 15-3 The Sequence of Page Program and Erase of Flash Memory	158
Figure 15-4 The Sequence of Bulk Erase of Flash Memory	159
Figure 15-5 Pin Diagram for Parallel Programming	163
Figure 15-6 Parallel Byte Read Timing of Program Memory	164
Figure 15-7 Parallel Byte Write Timing of Program Memory.....	165
Figure 15-8 ISP Mode	166
Figure 15-9 Byte-parallel Mode	166

MC96FT242

CMOS SINGLE-CHIP 8-BIT MICROCONTROLLER WITH 24CH TOUCH SWITCH

1. Overview

1.1 Description

The MC96FT242 is an advanced CMOS 8-bit microcontroller with 24K bytes of FLASH. This is powerful microcontroller which provides a highly flexible and cost effective solution to many embedded control applications. This provides the following features : 24Ch Self Capacitive Touch switch, 24K bytes of FLASH, 256 bytes of SRAM, 1792 bytes of XRAM, 16-bit timer/counter, Buzzer, Free Run Counter, Watchdog timer, I²C, USART, on-chip POR, BOD and 16-bit PWM output, on-chip oscillator and clock circuitry. The MC96FT242 also supports power saving modes to reduce power consumption.

Device Name	FLASH	SRAM	Package
MC96FT242U	24K bytes	I : 256 bytes X : 1792 bytes	32 QFN
MC96FT242L			32 LQFP
MC96FT242D			32 SOP
MC96FT202D			28 SOP
MC96FT162D			24 SOP

1.2 Features

- **CPU**
 - 8 Bit CISC Core (8051 Compatible, 2 Clocks per Cycle)
- **24K Bytes On-chip FLASH**
 - Endurance : 10,000 times
 - Retention : 10 years
- **256 Bytes SRAM**
- **1,792 Bytes XRAM**
- **General Purpose I/O**
 - 30 Ports (P0[7:0], P1[5:0], P2[7:0], P3[7:0]) : 32-pin Package
 - 26 Ports (P0[7:0], P1[5:0], P2[7:0], P3[3:0]) : 28-pin Package
- **22 Ports (P0[7:0], P1[5:0], P2[7:0]) : 24-pin Package**
- **24-Ch Self Capacitive Touch Switch**
 - 16-bit Sensing Resolutions
 - Fast Initial Self-Calibration.
 - Key Detection Mode : Single/Multi-Mode
 - The Improvement of the SNR by Bias-Calibration in analog sensing block
- **32-bit Free Counter**
- **Basic Interval Timer**
- **Timer / Counter**
 - 16 Bits x 3 Channels
- **3-ch 16-bit PWM (using Timer0, 1, 2)**
- **Watch Dog Timer**

- **2-ch Buzzer Driver**
- **I2C**
- **USART**
- **12 BIT AD Converter**
 - 8 Input Channel
- **Interrupt Sources**
 - PCI (2)
 - USART(2)
 - ADC(1)
 - Timer (3)
 - Free Run Counter (1)
 - I²C (1)
 - WDT (1)
 - BIT (1)
 - TOUCH (1)
 - ROM (1)
- **On-Chip RC-Oscillator**
 - 16MHz ($\pm 3\%$ @-40~+85°C)
- **Power On Reset**
 - 1.4V
- **Programmable Brown-Out Detector**
 - 1.6V / 2.5V / 3.6V / 4.2V
- **Minimum Instruction Execution Time**
 - 200ns (@10MHz, NOP Instruction)
- **Power down mode**
 - IDLE, STOP1, STOP2 mode
- **Operating Frequency**
 - 2, 4, 8, 16MHz (internal RC oscillator)
- **Operating Voltage**
 - 2.7V ~ 5.5V (@ 16MHz)
- **Operating Temperature : -40 ~ +85°C**
- **Package Type**
 - 32, 28, 24 SOP
 - 32 LQFP
 - 32 QFN

1.3 Ordering Information

Table 1-1 Ordering Information of MC96FT242

Device name	ROM size	SRAM size	Package
MC96FT242U	24Kbytes FLASH	I:256 bytes X:1792 bytes	32 QFN
MC96FT242L			32 LQFP
MC96FT242D			32 SOP
MC96FT202D			28 SOP
MC96FT162D			24 SOP

1.4 Development Tools

1.4.1 Compiler

We do not provide the compiler. Please contact third parties.

The MC96FT242 core is Mentor 8051. Anyway, device ROM size is smaller than 64KB. Developer can use all kinds of third party's standard 8051 compiler.

1.4.2 OCD emulator and debugger

The OCD (On Chip Debug) emulator supports ABOV Semiconductor's 8051 series MCU emulation.

The OCD interface uses two wires interfacing between PC and MCU which is attached to user's system. The OCD can read or change the value of MCU internal memory and I/O peripherals. And also the OCD controls MCU internal debugging logic, it means OCD controls emulation, step run, monitoring, etc.

If you want to see more details, please refer OCD debugger manual. You can download debugger S/W and manual from our web-site.

Connection:

- P10 (MC96FT242 DSDA pin)
- P11 (MC96FT242 DSCL pin)

OCD connector diagram: Connect OCD and user system

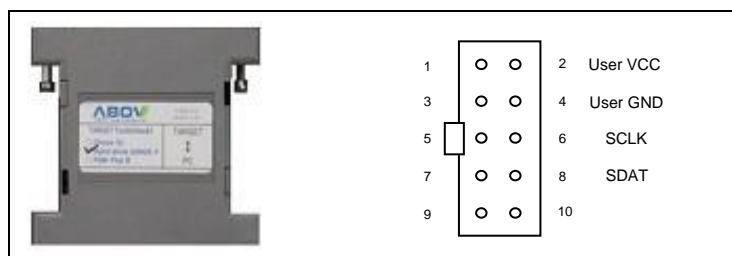

Figure 1-1 OCD Debugger and Pin Description

1.4.3 Programmer

Single programmer:

PGMplus USB: It programs MCU device directly.



Figure 1-2 Single Programmer

OCD emulator : It can write code in MCU device too.

Because of, OCD debugging supports ISP (In System Programming).

It does not require additional H/W, except developer's target system.

Gang programmer :

It programs 8 MCU devices at once.

So, it is mainly used in mass production line.

Gang programmer is standalone type, it means it does not require host PC.



Figure 1-3 Gang Programmer

2. Block Diagram

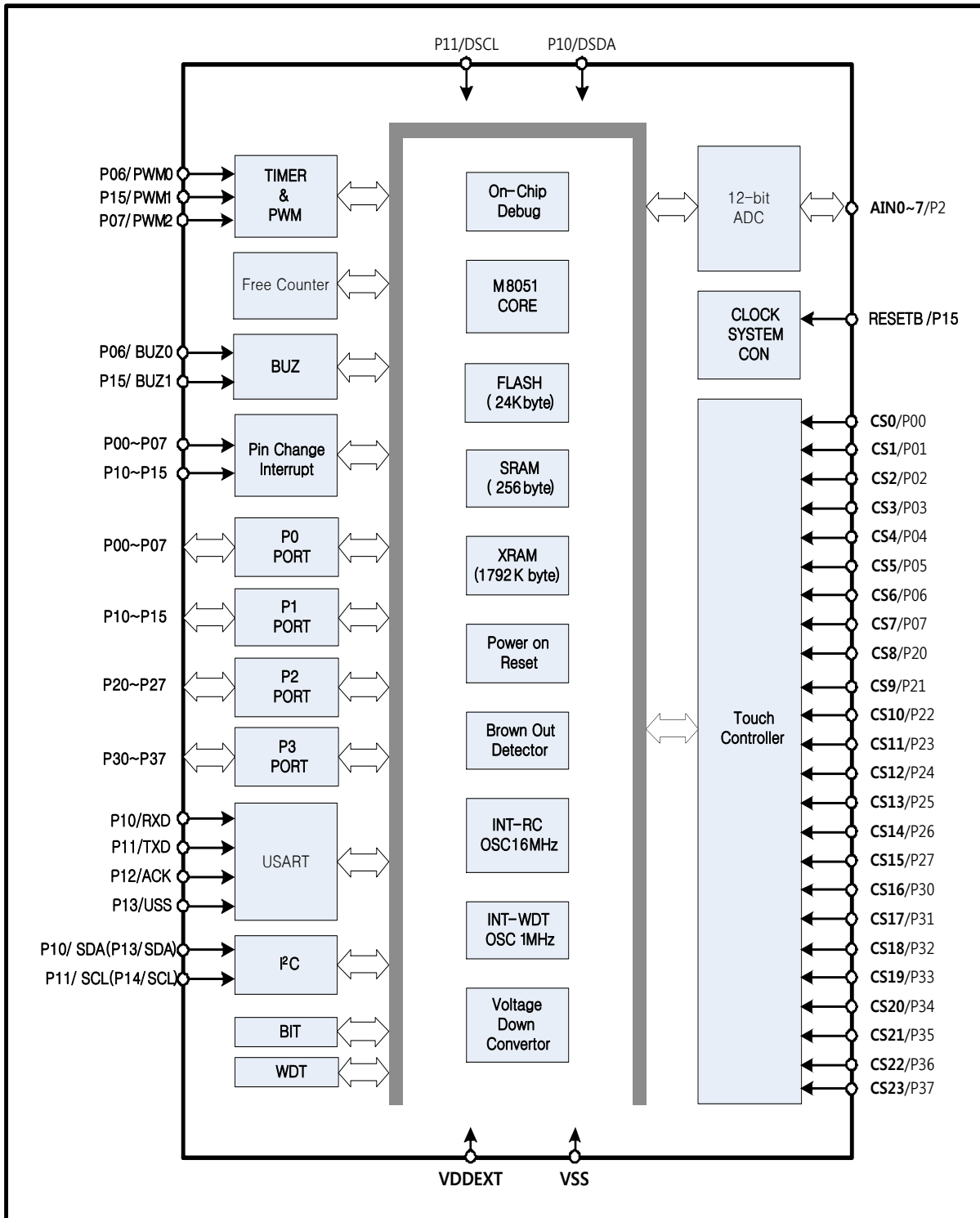

Figure 2-1 MC96FT242 Block Diagram

3. Pin Assignment

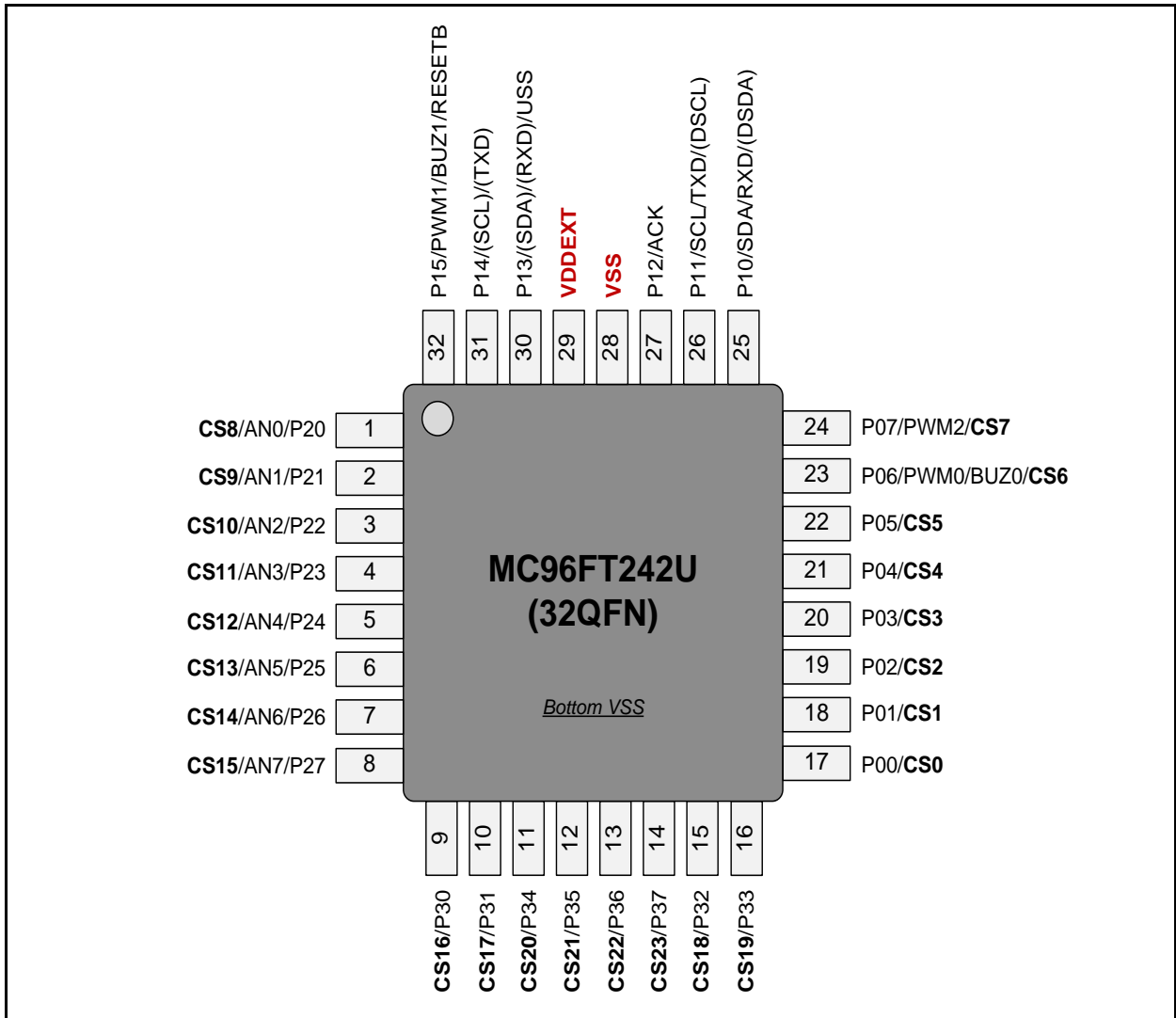

Figure 3-1 MC96FT242 32 QFN Pin Assignment

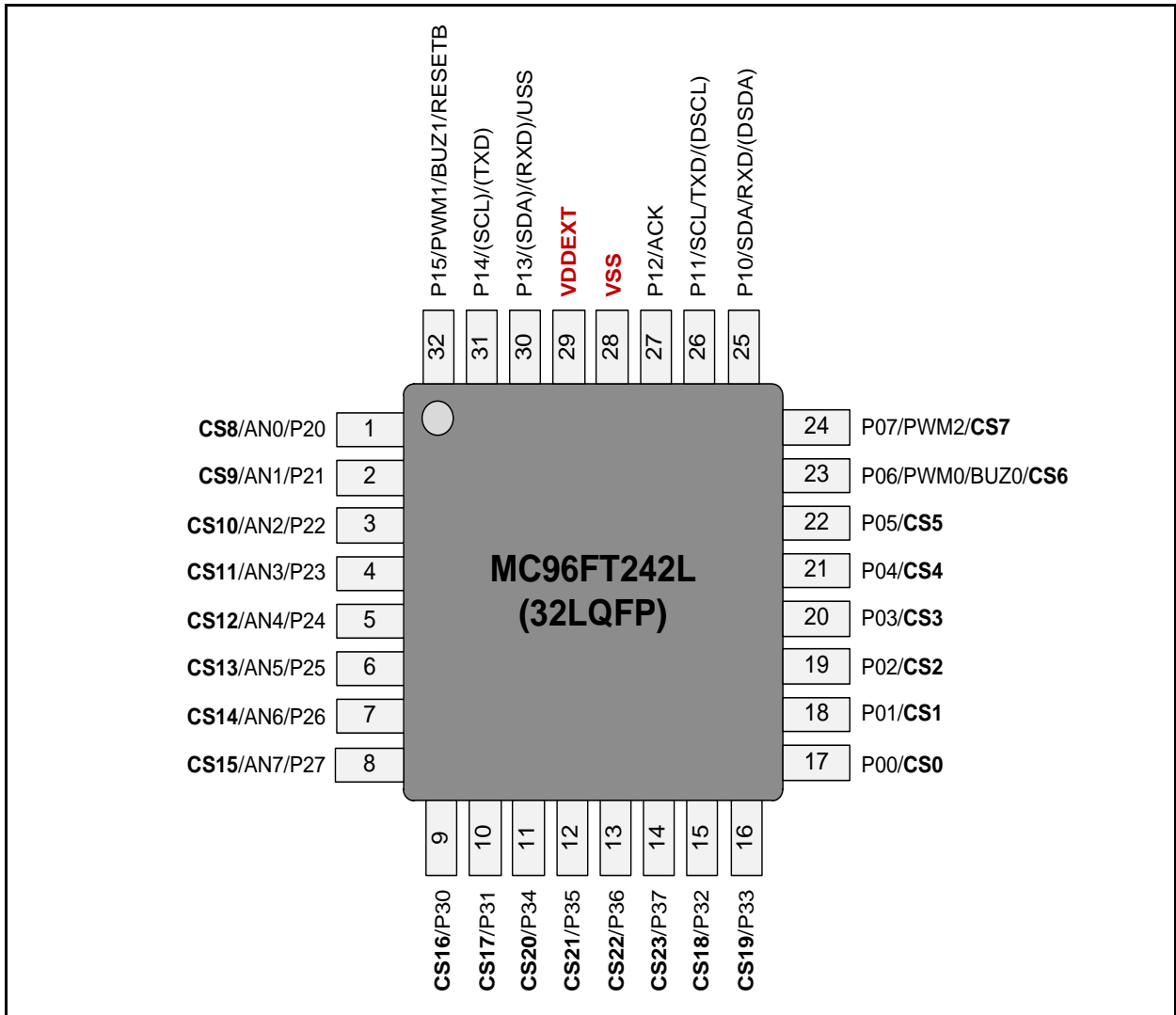

Figure 3-2 MC96FT242 32 LQFP Pin Assignment

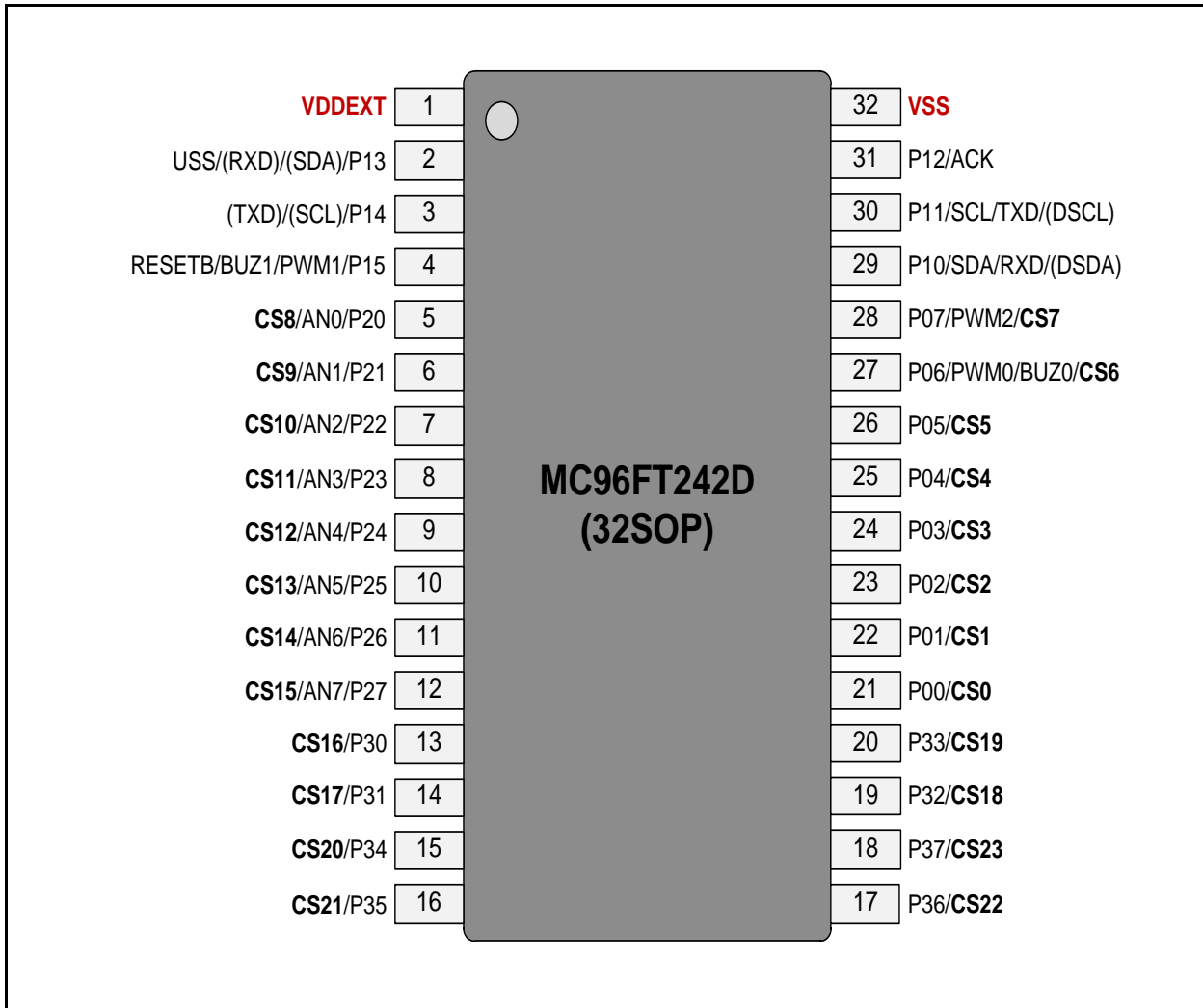

Figure 3-3 MC96FT242 32 SOP Pin Assignment

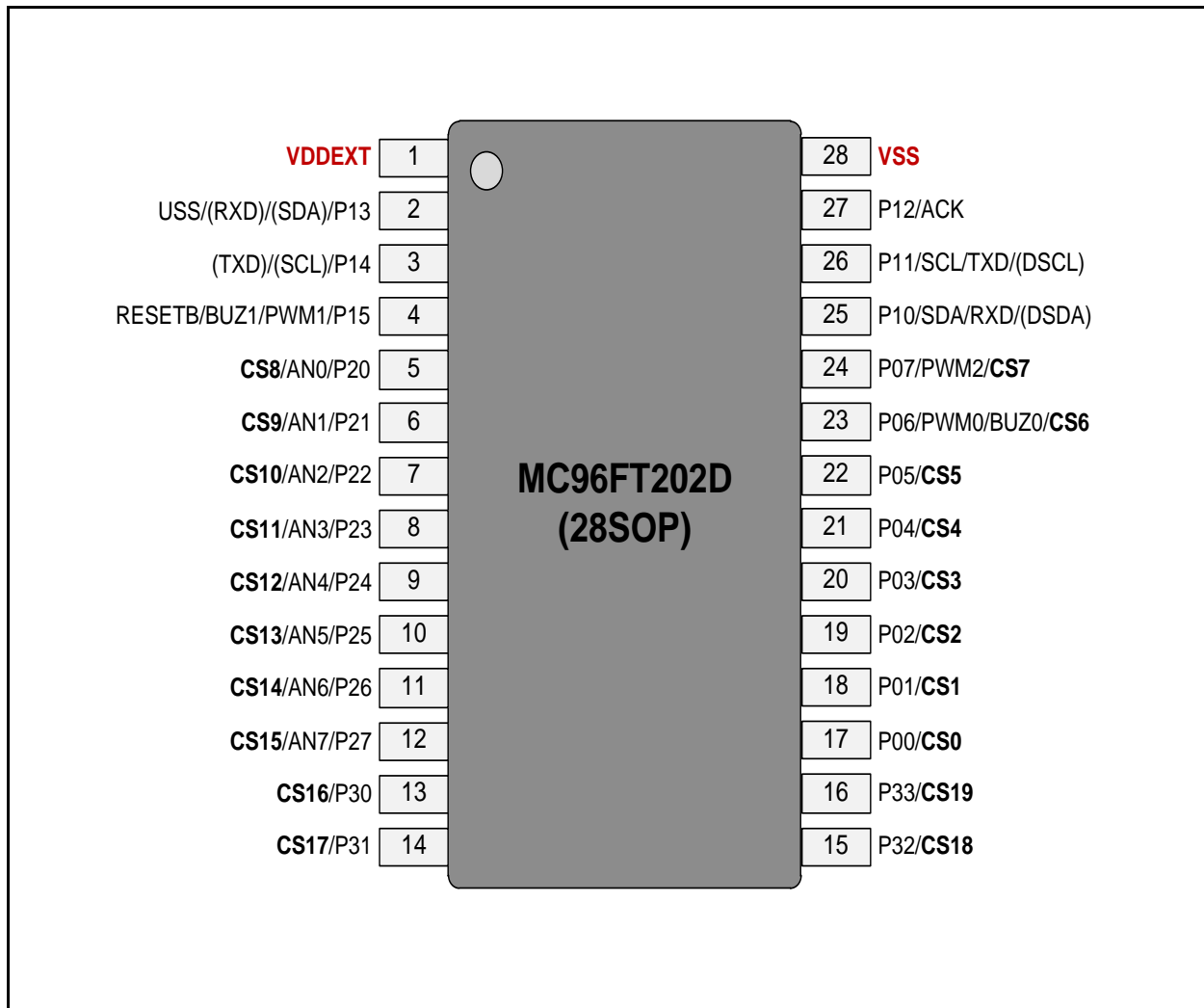

Figure 3-4 MC96FT202 28 SOP Pin Assignment

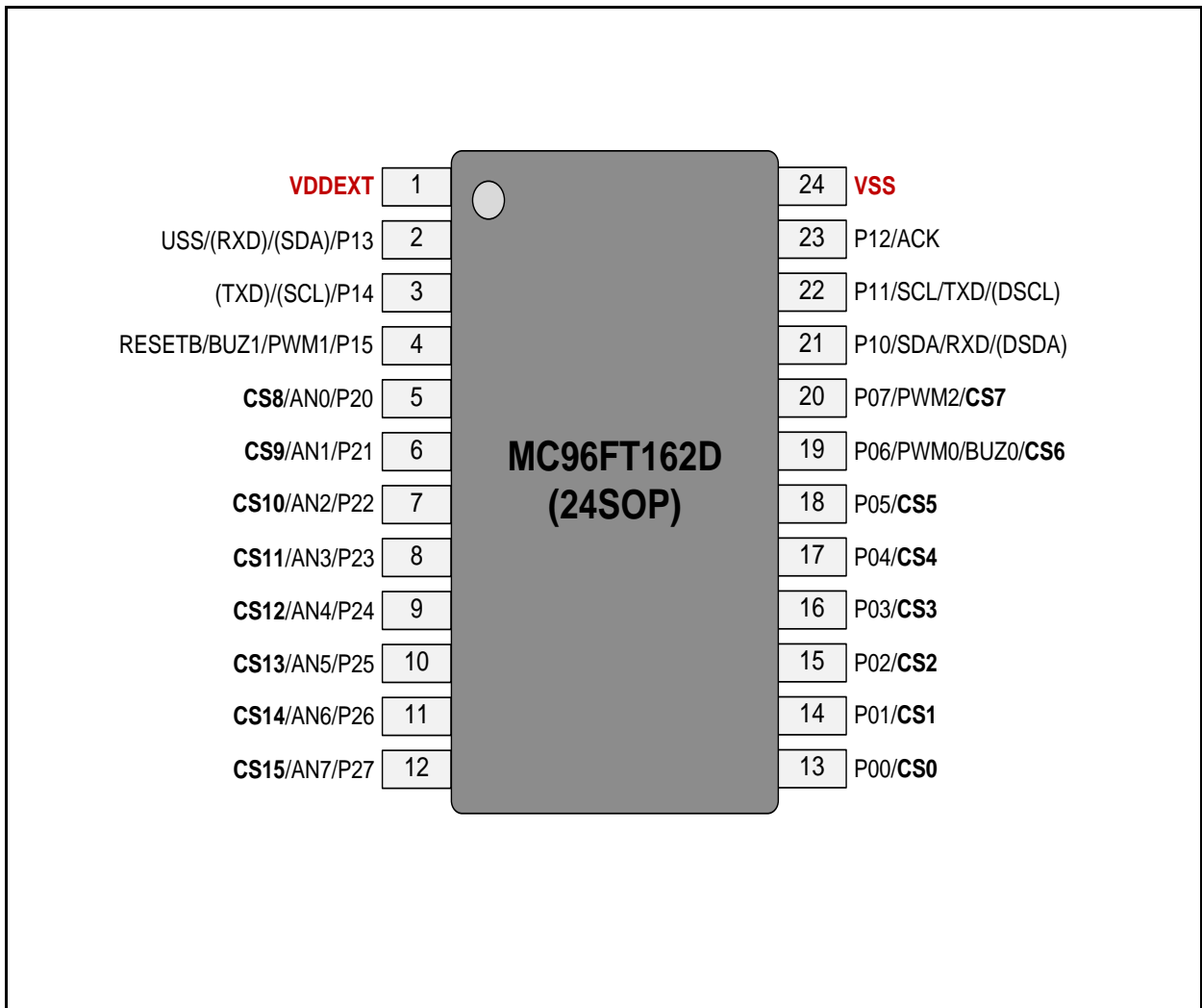

Figure 3-5 MC96FT162 24 SOP Pin Assignment

4. Package Diagram

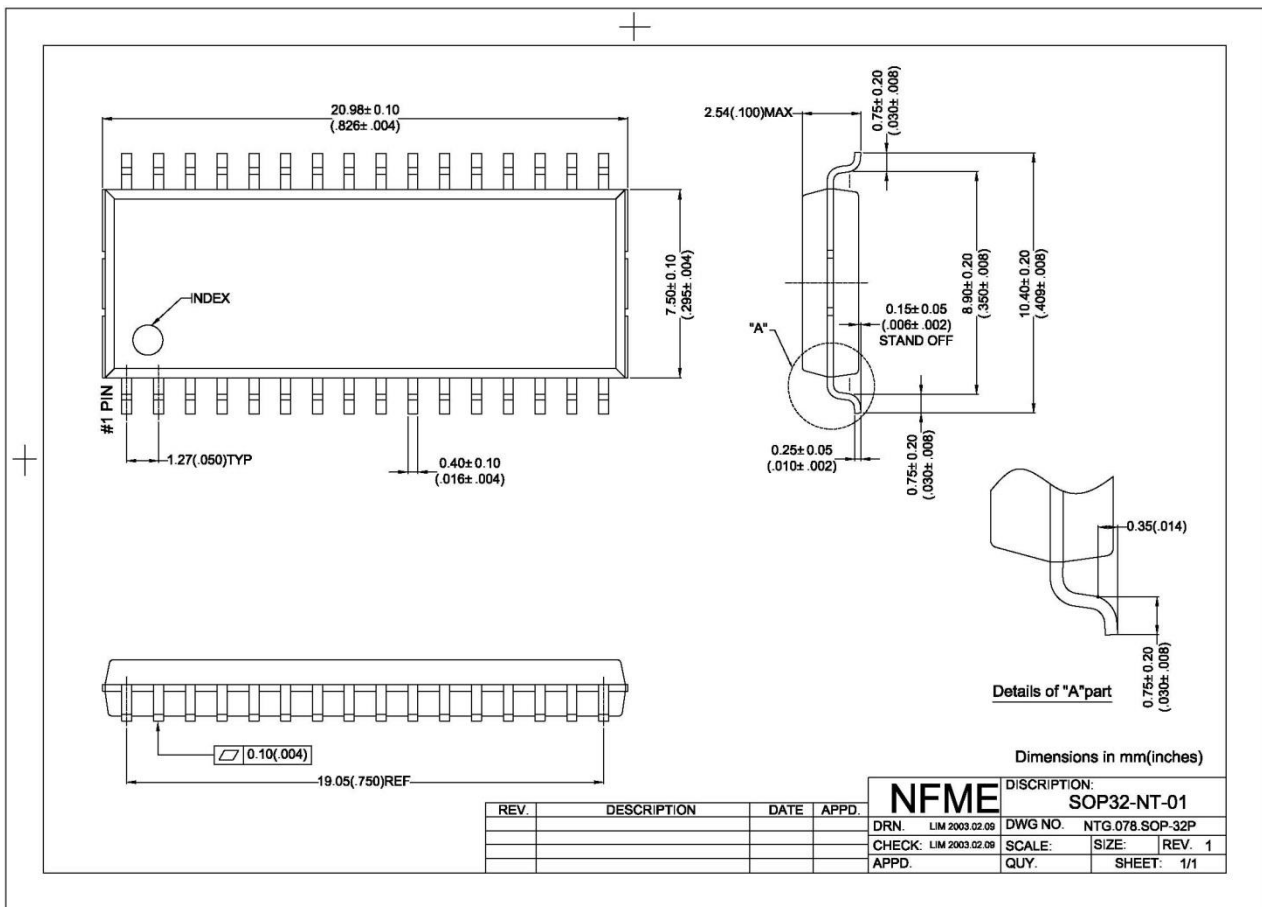

Figure 4-1 32 pin SOP Package

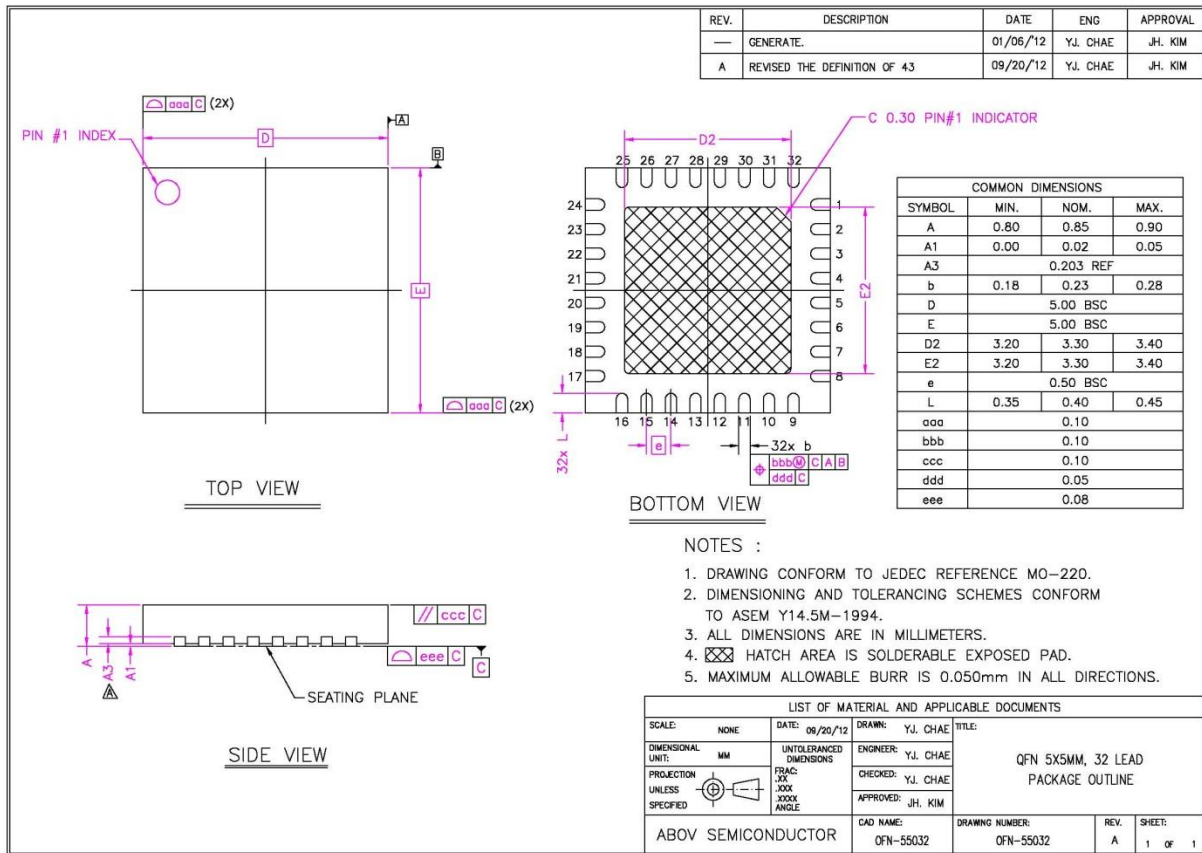

Figure 4-2 32 pin QFN Package

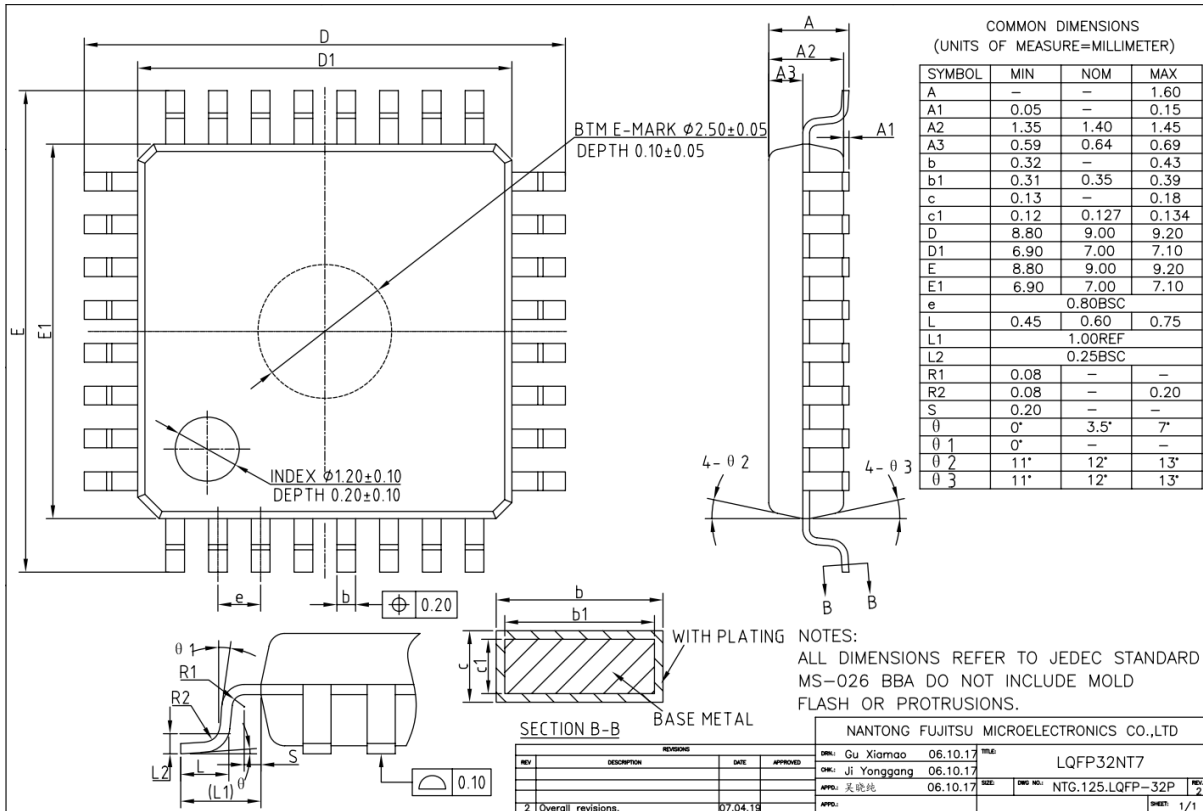

Figure 4-3 32 pin LQFP Package

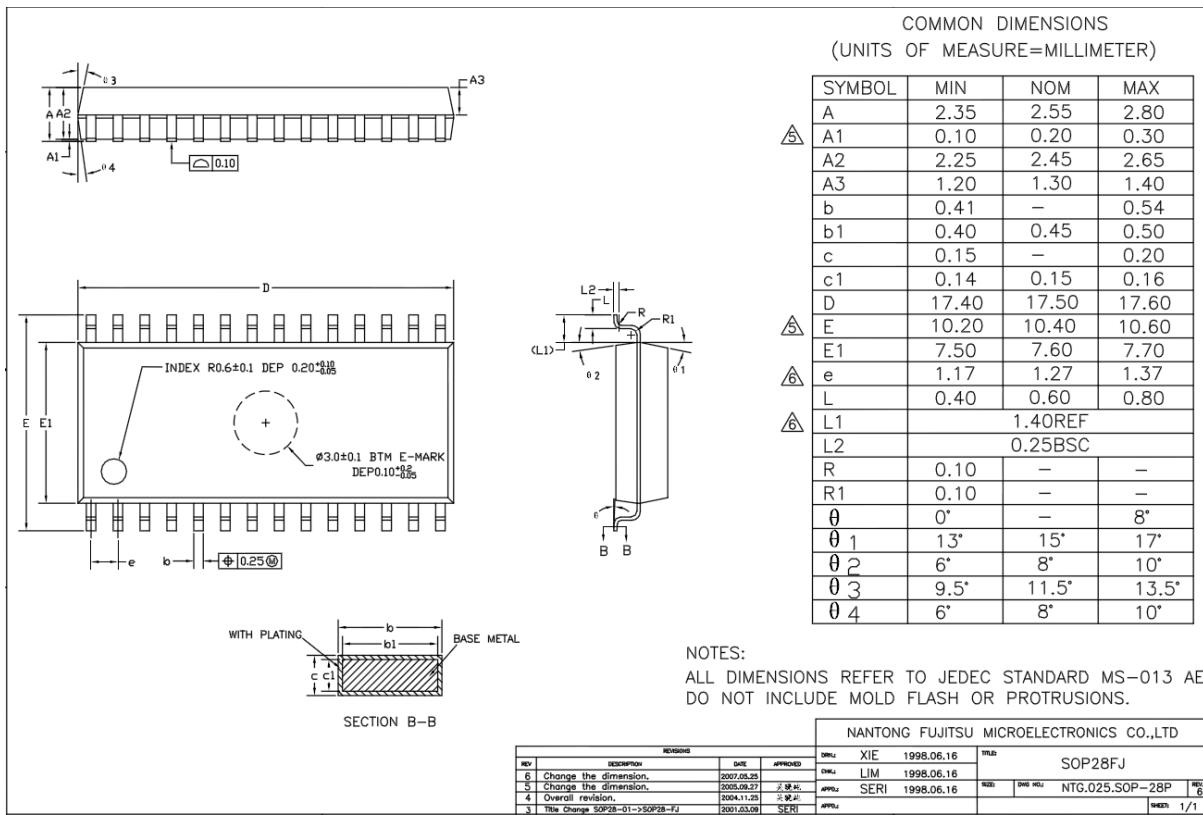

Figure 4-4 28 pin SOP Package

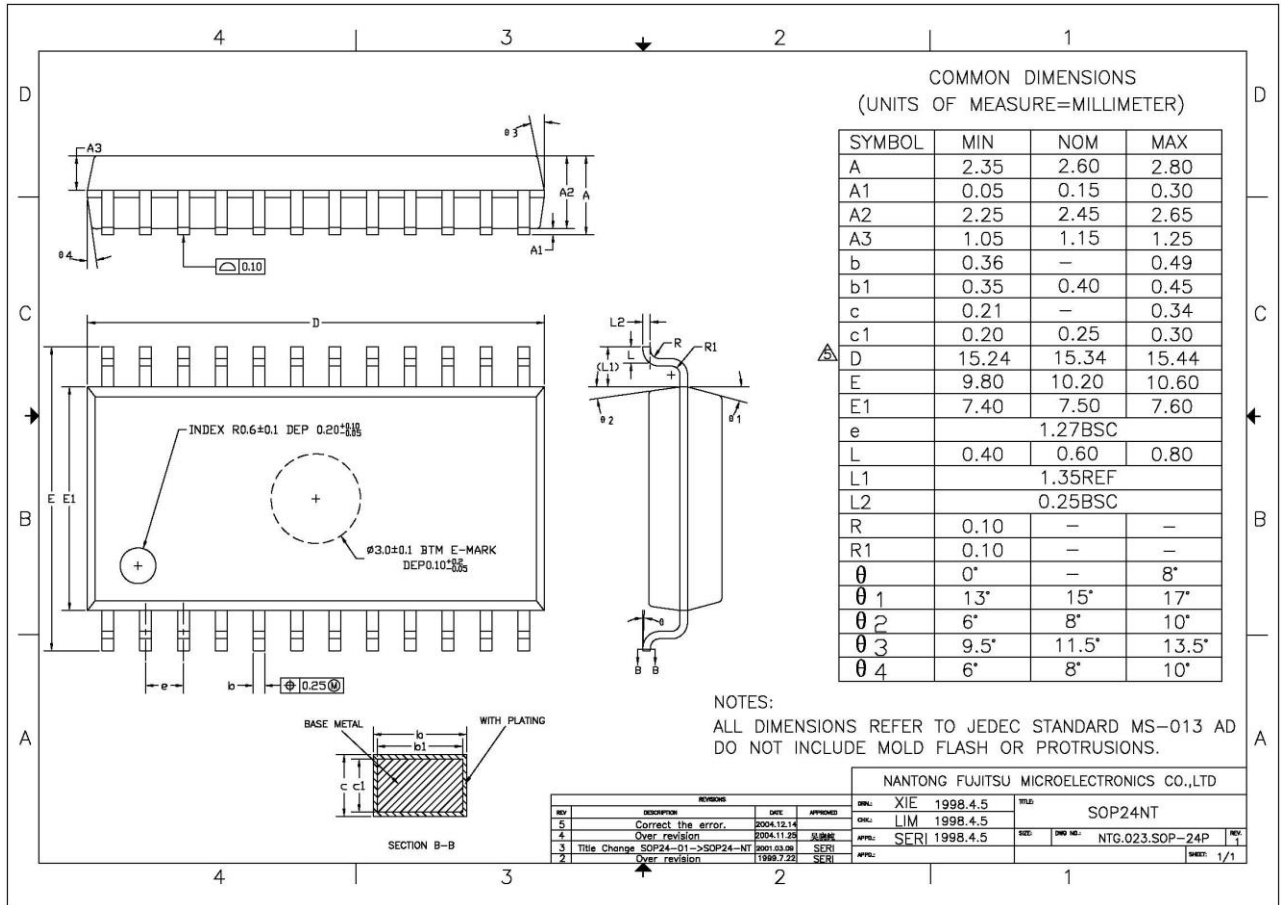

Figure 4-5 24 pin SOP Package

5. Pin Description

Table 5-1 Normal Pin Description

PIN Name			I/O	Function	@RES ET	Shared with
24PIN	28PIN	32PIN				
P00	P00	P00	I/O	Port P0 8-Bit I/O Port Can be set in input or output mode in 1-bit units Internal pull-up register can be used via software when this port is used as input port Open Drain enable register can be used via software when this port is used as output port	Input	CS0
P01	P01	P01				CS1
P02	P02	P02				CS2
P03	P03	P03				CS3
P04	P04	P04				CS4
P05	P05	P05				CS5
P06	P06	P06				PWM0/BUZ0/CS6
P07	P07	P07				PWM2/CS7
P10	P10	P10	I/O	Port P1 6-Bit I/O Port Can be set in input or output mode in 1-bit units Internal pull-up register can be used via software when this port is used as input port Open Drain enable register can be used via software when this port is used as output port	Input	SDA/RXD/(DSDA)
P11	P11	P11				SCL/TXD/(DSCL)
P12	P12	P12				ACK1
P13	P13	P13				USS1/(RXD)/(SDA)
P14	P14	P14				(TXD)/(SCL)
P15	P15	P15				RESETB/BUZ1/PWM1
P20	P20	P20	I/O	Port P2 8-Bit I/O Port Can be set in input or output mode in 1-bit units Internal pull-up register can be used via software when this port is used as input port Open Drain enable register can be used via software when this port is used as output port	Input	AN0/CS8
P21	P21	P21				AN1/CS9
P22	P22	P22				AN2/CS10
P23	P23	P23				AN3/CS11
P24	P24	P24				AN4/CS12
P25	P25	P25				AN5/CS13
P26	P26	P26				AN6/CS14
P27	P27	P27				AN7/CS15
-	P30	P30	I/O	Port P3 8-Bit I/O Port Can be set in input or output mode in 1-bit units Internal pull-up register can be used via software when this port is used as input port Open Drain enable register can be used via software when this port is used as output port	Input	CS16
-	P31	P31				CS17
-	P32	P32				CS18
-	P33	P33				CS19
-		P34				CS20
-		P35				CS21
-		P36				CS22
-		P37				CS23

6. Port Structures

6.1 General Purpose I/O Port

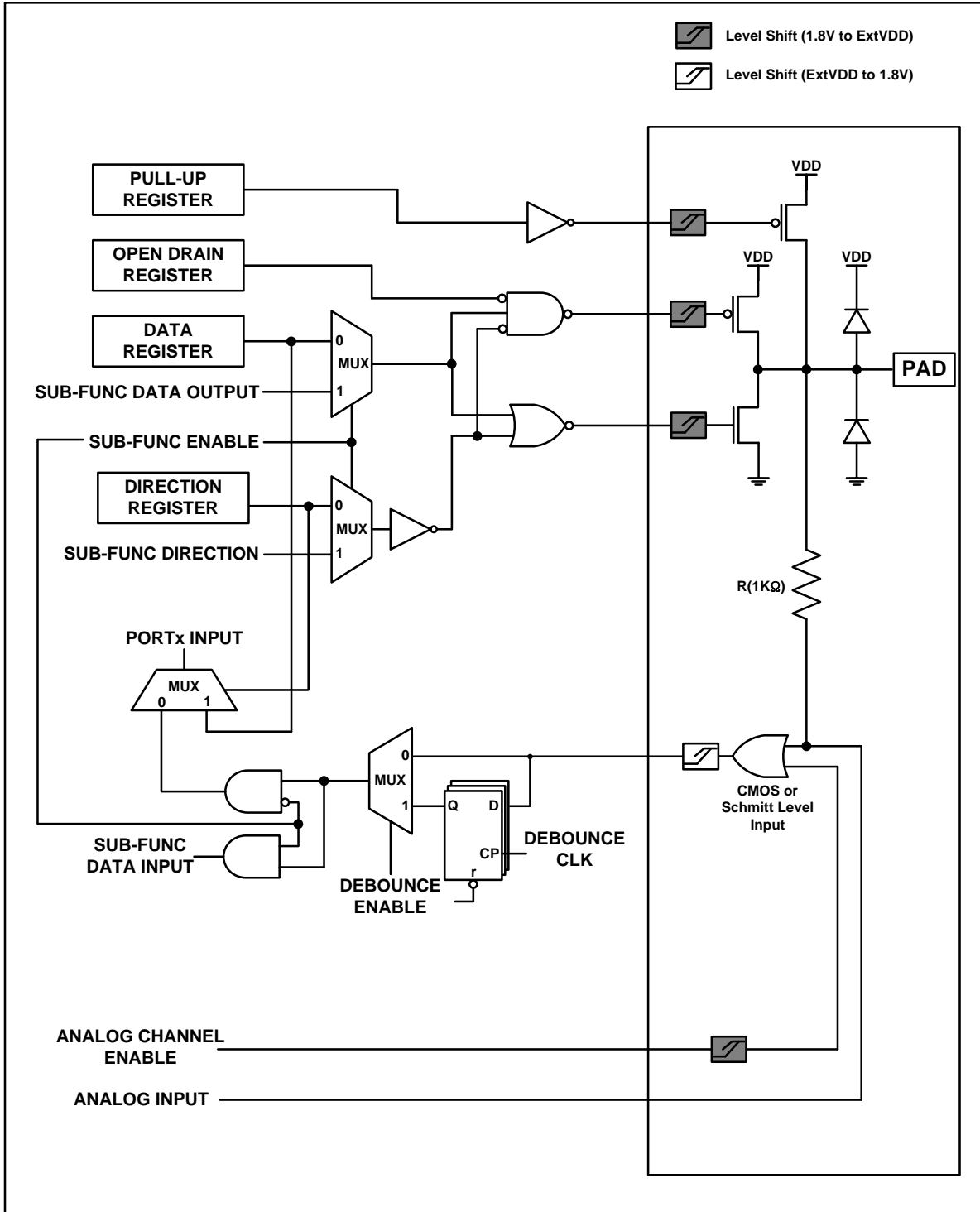

Figure 6-1 General Purpose I/O Port

7. Electrical Characteristics

Absolute Maximum Ratings

Table 7-1 Absolute Maximum Ratings

Parameter	Symbol	Rating	Unit
Supply Voltage	VDD	-0.3~+6.5	V
	VSS	-0.3~+0.3	V
Normal Voltage Pin	VI	-0.3~VDD+0.3	V
	VO	-0.3~VDD+0.3	V
	IOH	10	mA
	ΣIOH	80	mA
	IOL	20	mA
	ΣIOL	160	mA
	Total Power Dissipation	PT	600
Storage Temperature	TSTG	-65~+150	°C

Note) Stresses beyond those listed under “Absolute Maximum Ratings” may cause permanent damage to the device. This is a stress rating only and functional operation of the device at any other conditions beyond those indicated in the operational sections of this specification is not implied. Exposure to absolute maximum rating conditions for extended periods may affect device reliability.

7.1 Recommended Operating Conditions

Table 7-2 Recommended Operation Conditions

Parameter	Symbol	Condition	MIN	TYP	MAX	Unit
Supply Voltage	VDD	Internal RC-OSC 16MHz	2.7	-	5.5	V
Operating Temperature	TOPR	VDD=2.7~5.5V	-40	-	85	°C
Operating Frequency		Internal RC-OSC	-	16	-	MHz
		Internal Ring-OSC	-	1		MHz

7.2 Voltage Dropout Converter Characteristics

Table 7-3 Voltage Dropout Converter Characteristics

Parameter	Symbol	Condition	MIN	TYP	MAX	Unit
Operating Voltage		-	2.7	-	5.5	V
Operating Temperature		-	-40	-	+85	°C
Regulation Voltage		-	1.62	1.8	1.98	V
Drop-out Voltage		-	-	-	0.02	V
Current Drivability		RUN/IDLE	-	20	-	mA
		SUB-ACTIVE	-	1	-	mA
		STOP1	-	50	-	uA
		STOP2	-	10	-	uA
Operating Current	IDD1	RUN/IDLE	-	-	1	mA
	IDD2	SUB-ACTIVE	-	-	0.1	mA
	SIDD1	STOP1	-	-	5	uA
	SIDD2	STOP2	-	-	0.1	uA
Drivability Transition Time	TRAN1	SUB to RUN	-	-	1	us
	TRAN2	STOP to RUN	-	-	200	us

Note) -STOP1: WDT running - STOP2: WDT disable

7.3 Power-On Reset Characteristics

Table 7-4 Power-On Reset Characteristics

Parameter	Symbol	Condition	MIN	TYP	MAX	Unit
Operating Voltage		-	VSS	-	5.5	V
Operating Temperature		-	-40	-	+85	°C
RESET Release Level		-	1.3	1.4	1.5	V
Operating Current	IDD	-	-	-	10	uA
	SIDD	-	-	-	1	uA

7.4 Touch Switch Characteristics

Table 7-5 Absolute Maximum Ratings

Symbol	Parameter	Max	Max
V _{DD}	Positive Supply	6.5	V

Note: Absolute Maximum Ratings are those values beyond which damage to the device may occur. Functional operation under these conditions is not implied.

(V_{DD} =2.7~5.5V, V_{SS} =0V, T_A=-40~+85℃)

Table 7-6 Touch Switch Characteristics

Parameter	Symbol	Condition	MIN	TYP	MAX	Unit
Operating Voltage	V _{DD}	-	2.7	-	5.5	V
	V _{DDA}	-	2.7	-	5.5	V
VDC Voltage	V _{CCL}	From MCU	-	1.85	-	V
SNR (Signal-to-Noise Ratio)	SNR		-	20	-	dB
Self-Calibration Time	T _{CAL}	-	-	10	-	ms
Scan Speed	T _{SCAN}		-	10	-	ms
Supply Current	I _{VDD}		-	T.B.D	-	mA
Operation Temperature	T _{OPER}	-	40	-	85	℃

7.5 Brown Out Detector Characteristics

Table 7-7 Brown Out Detector Characteristics

Parameter	Symbol	Condition	MIN	TYP	MAX	Unit
Operating Voltage		-	VSS	-	5.5	V
Operating Temperature		-	-40	-	+85	℃
Detection Level	4.2V	-	4.0	-	4.4	V
	3.6V	-	3.4	-	3.8	V
	2.5V	-	2.3	-	2.7	V
	1.6V	-	1.4	-	1.8	V
Hysteresis		-	-	-	-	mV
Operating Current	IDD	-	-	-	50	uA
	SIDD	-	-	-	1	uA

7.6 Internal RC Oscillator Characteristics

Table 7-8 Internal RC Oscillator Characteristics

Parameter	Symbol	Condition	MIN	TYP	MAX	Unit
Operating Voltage		-	2.7	-	5.5	V
Operating Temperature		-	-40	-	+85	°C
Frequency		-	15.52	16	16.48	MHz
Stabilization Time		-	-	-	10	ms
Operating Current	IDD	-	-	-	-	uA
	SIDD	-	-	-	1	uA

7.7 Ring-Oscillator Characteristics

Table 7-9 Ring-Oscillator Characteristics

Parameter	Symbol	Condition	MIN	TYP	MAX	Unit
Operating Voltage		-	2.7	-	5.5	V
Operating Temperature		-	-40	-	+85	°C
Frequency		-	0.5	1	1.5	MHz
Stabilization Time		-	-	-	-	ms
Operating Current	IDD	-	-	-	-	uA
	SIDD	-	-	-	1	uA

7.8 A/D Converter Characteristics

Table 7-10 A/D Converter Characteristics

Parameter	Symbol	Condition	MIN	TYP	MAX	Unit
A/D converting Resolution	-	-	-	12	-	bits
Integral Linearity Error	ILE	VDD=5.12V, Vss=0V, TA=+25°C	-	-	±6	LSB
Differential Linearity Error	DLE		-	-	±3	
Offset Error of Top	EOT		-	-±1	±6	
Zero Offset Error	EOB		-	±1	±6	
Overall Accuracy	-		-	-	±3	
Conversion Time	tCONV	-	-	60	-	Cycle
Analog Input Voltage	VAIN	-	VSS	-	Vref	V
Analog Input Current	IAIN	VDD=5V	-	-	10	uA
Analog Block Current	IAVDD	VDD=5V	-	1	3	mA
		VDD=3V	-	0.5	1.5	
		VDD=5V (Power	-	1	5	uA

		down mode)				
--	--	------------	--	--	--	--

(TA=-40°C ~ +85°C, VDD=2.7V ~ 5.5V, VSS=0V)

7.9 DC Characteristics

(VDD =2.7~5.5V, VSS =0V, f_{XIN}=10.0MHz, TA=-40~+85°C)

Table 7-11 DC Characteristics

Parameter	Symbol	Condition	MIN	TYP	MAX	Unit
Input Low Voltage	VIL	ALL I/O	-0.5	-	0.3VDD	V
Input High Voltage	VIH	ALL I/O	0.7VDD	-	VDD	V
Output Low Voltage	VOL1	ALL I/O (IOL=20mA, VDD=4.5V)	-	-	1	V
Output High Voltage	VOH1	ALL I/O (IOH=-8.57mA, VDD=4.5V)	3.5	-	-	V
Input High Leakage Current	IIH	ALL PAD	-	-	1	uA
Input Low Leakage Current	IIL	ALL PAD	-1	-	-	uA
Pull-Up Resister	RPU1	ALL PAD @5V	30	-	70	kΩ
	RPU2	ALL PAD @3V	70	-	150	kΩ
Power Supply Current	IDD1	Run Mode, 16MHz @5V	-	TBD	-	mA
	IDD2	Sleep Mode, 16MHz @5V	-	TBD	-	mA
	IDD3	STOP1 Mode, WDT Active @5V (BOD enable)	-	50	-	uA
	IDD4	STOP1 Mode, WDT Active @5V (BOD disable)	-	16	-	uA
	IDD5	STOP2 Mode, WDT Disable @5V (BOD enable)	-	30	-	uA
	IDD6	STOP2 Mode, WDT Disable @5V (BOD disable)	-	1	-	uA

Note) STOP1: WDT only running, STOP2: All function disable.

7.10 AC Characteristics

Table 7-12 AC Characteri (VDD=5.0V±10%, VSS=0V, TA=-40~+85°C)

Parameter	Symbol	PIN	MIN	TYP	MAX	Unit
Operating Frequency	fMCP	-	2	-	16	MHz
System Clock Cycle Time	tSYS	-	62.5	-	500	ns
Oscillation Stabilization Time (16MHz)	tMST1	-	-	-	10	ms
Pin Change Interrupt Input Width	tIW	PCI0~PCI1	2	-	-	tSYS
Pin Change Interrupt Transition Time	tFI,tRI	PCI0~PCI1			1	us
nRESET Input Pulse "L" Width	tRST	nRESET	8	-	-	tSYS

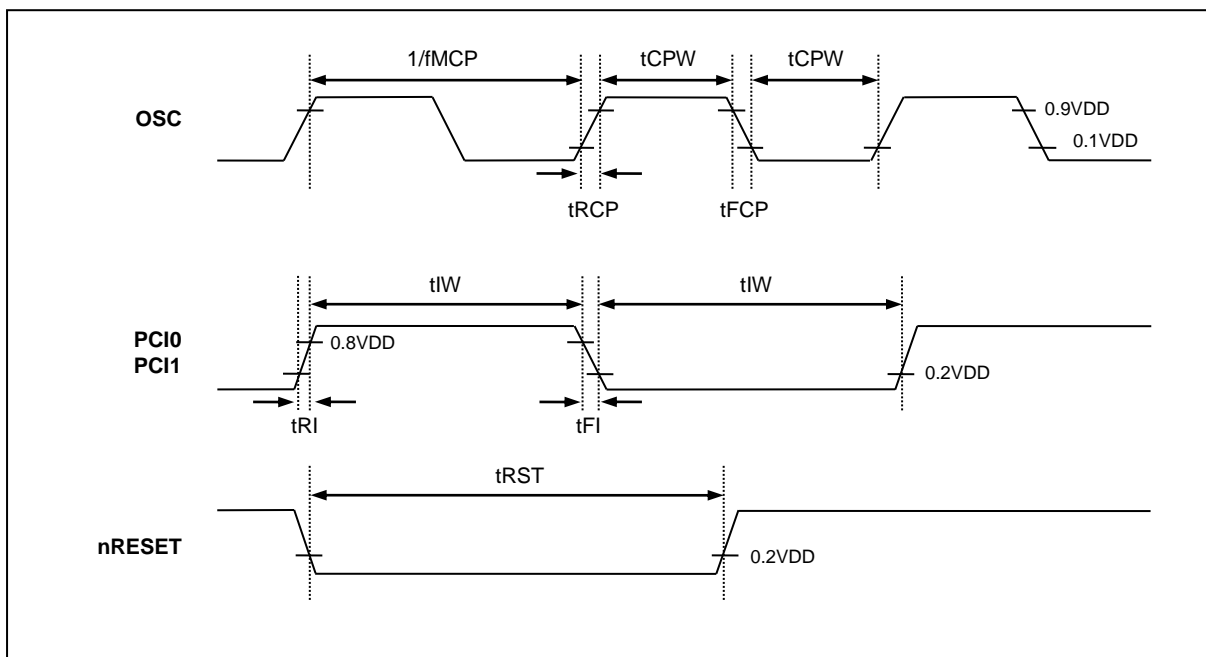

Figure 7-1 AC Timing

7.11 Typical Characteristics

These graphs and tables provided in this section are for design guidance only and are not tested or guaranteed. In some graphs or tables the data presented are outside specified operating range (e.g. outside specified VDD range). This is for information only and devices are guaranteed to operate properly only within the specified range.

The data presented in this section is a statistical summary of data collected on units from different lots over a period of time. “Typical” represents the mean of the distribution while “max” or “min” represents (mean + 3σ) and (mean - 3σ) respectively where σ is standard deviation.

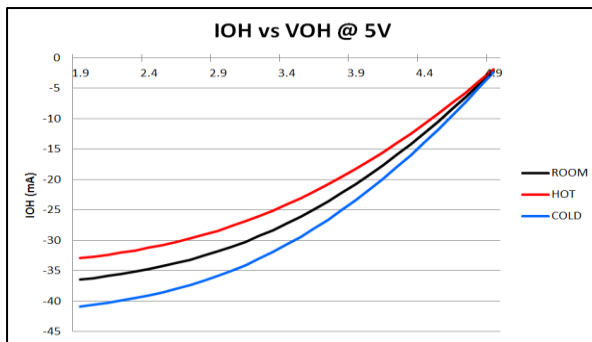

Figure 7-2 Output High Voltage (VOH)

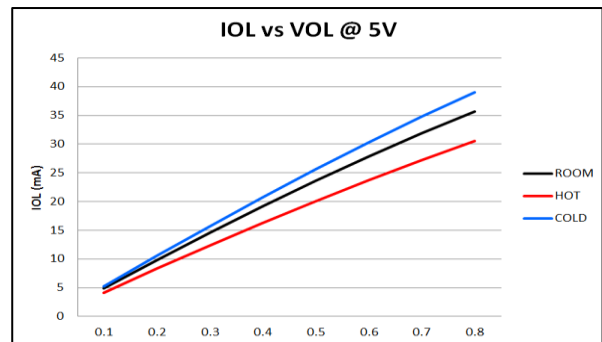

Figure 7-3 Output Low Voltage (VOL)

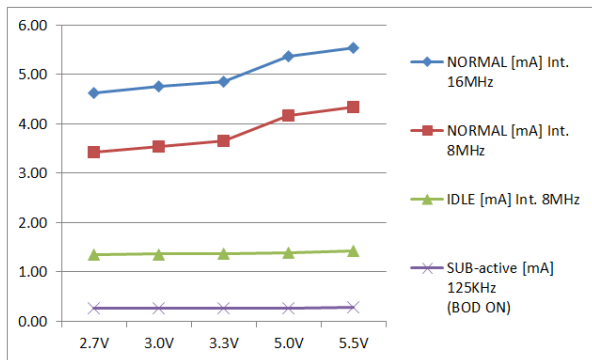

Figure 7-4 Active Current (Normal, Idle, Sub)

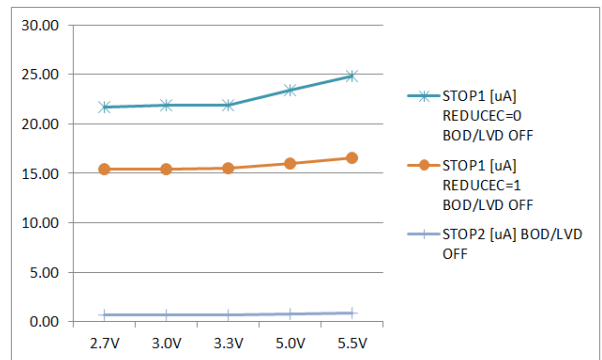

Figure 7-5 Stop Current (Stop1, Stop2)

8. Memory

The MC96FT242 addresses two separate address memory stores: Program memory and Data memory. The logical separation of Program and Data memory allows Data memory to be accessed by 8-bit addresses, which can be more quickly stored and manipulated by 8-bit CPU. Nevertheless, 16-bit Data memory addresses can also be generated through the DPTR register.

Program memory can only be read, not written to. There can be up to 64K bytes of Program memory in a bank. In the MC96FT242 FLASH version of these devices the 24K bytes of Program memory are provided on-chip. Data memory can be read and written to up to 256 bytes internal memory (DATA) including the stack area.

8.1 Program Memory

A 16-bit program counter is capable of addressing up to 64K bytes for one bank of memory space, but this device has 24K bytes program memory space.

Figure 8-1 shows a map of the lower part of the program memory. After reset, the CPU begins execution from location 0000H. Each interrupt is assigned a fixed location in program memory. The interrupt causes the CPU to jump to that location, where it commences execution of the service routine. PCI0 (Pin Change Interrupt 0), for example, is assigned to location 0003H. If PCI0 is going to be used, its service routine must begin at location 0003H. If the interrupt is not going to be used, its service location is available as general purpose program memory. If an interrupt service routine is short enough (as is often the case in control applications), it can reside entirely within that 8 byte interval. Longer service routines can use a jump instruction to skip over subsequent interrupt locations, if other interrupts are in use.

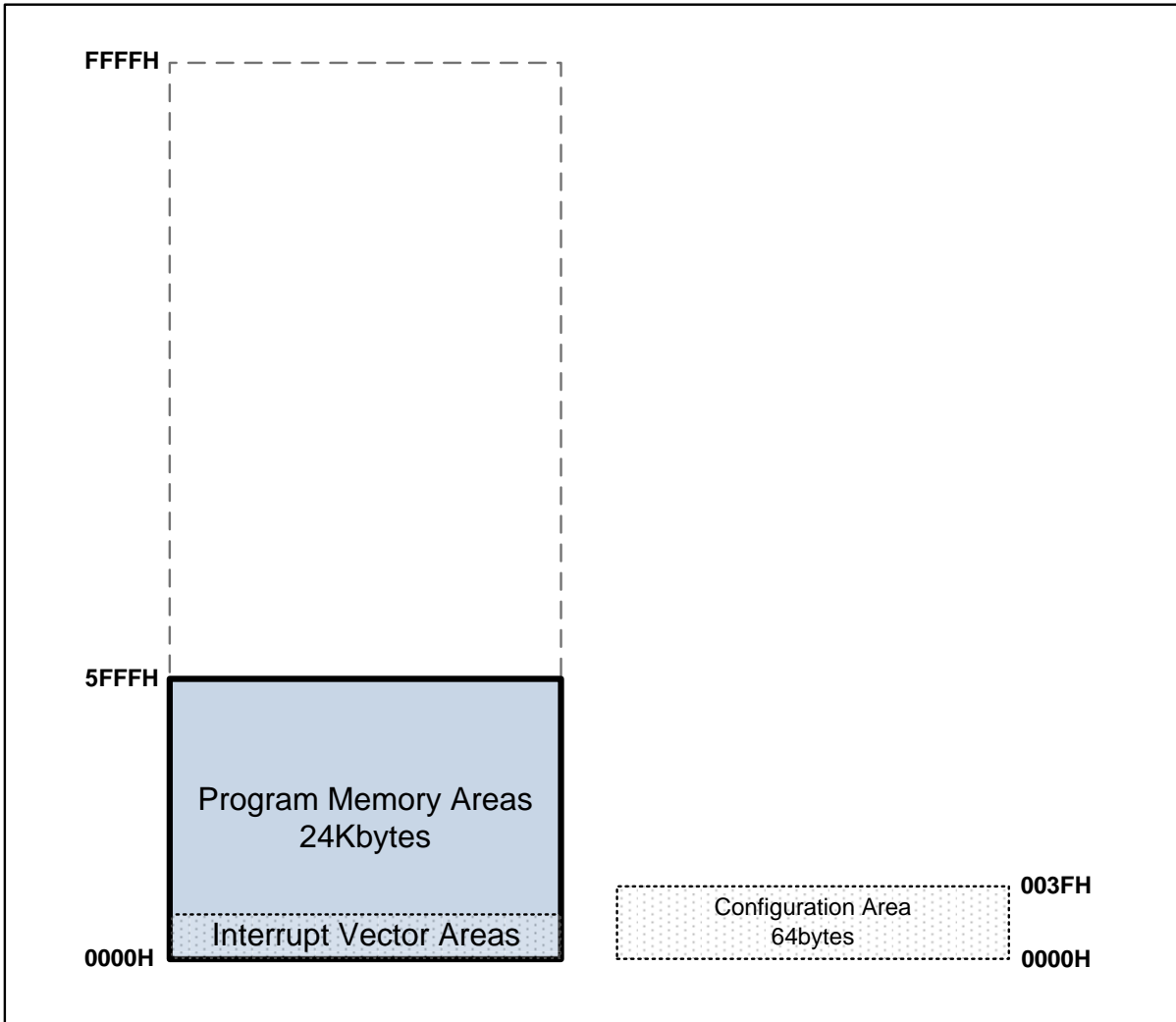

Figure 8-1 Program Memory

- User Function Mode: 24K Bytes Included Interrupt Vector Region
- Non-volatile and reprogramming memory: Flash memory based on EEPROM cell

8.2 Data Memory

Figure 8-2 shows the internal Data memory space available.

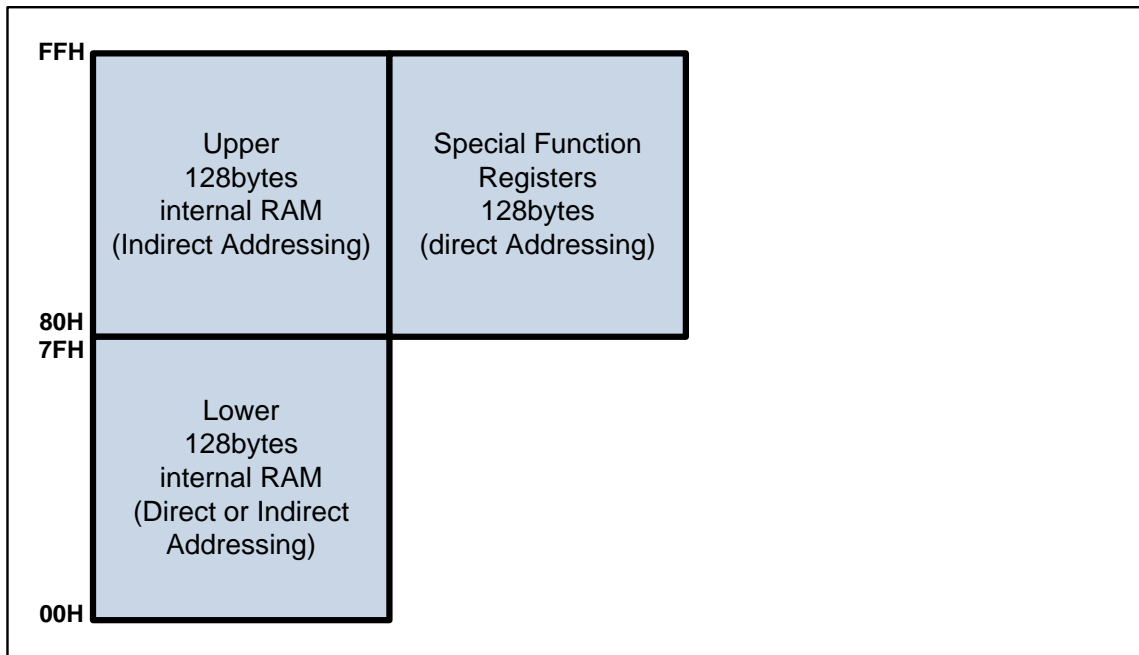

Figure 8-2 Data Memory Map

The internal memory space is divided into three blocks, which are generally referred to as the lower 128, upper 128, and SFR space.

Internal Data memory addresses are always one byte wide, which implies an address space of only 256 bytes. However, the addressing modes for internal RAM can in fact accommodate 384 bytes, using a simple trick. Direct addresses higher than 7FH access one memory space and indirect addresses higher than 7FH access a different memory space. Thus Figure 8-2 shows the upper 128 and SFR space occupying the same block of addresses, 80H through FFH, although they are physically separate entities.

The lower 128 bytes of RAM are present in all 8051 devices as mapped in figure 8-3. The lowest 32 bytes are grouped into 4 banks of 8 registers. Program instructions call out these registers as R0 through R7. Two bits in the Program Status Word select which register bank is in use. This allows more efficient use of code space, since register instructions are shorter than instructions that use direct addressing.

The next 16 bytes above the register banks form a block of bit-addressable memory space. The 8051 instruction set includes a wide selection of single-bit instructions, and the 128 bits in this area can be directly addressed by these instructions. The bit addresses in this area are 00H through 7FH.

All of the bytes in the lower 128 can be accessed by either direct or indirect addressing. The upper 128 bytes RAM can only be accessed by indirect addressing. These spaces are used for user RAM and stack pointer.

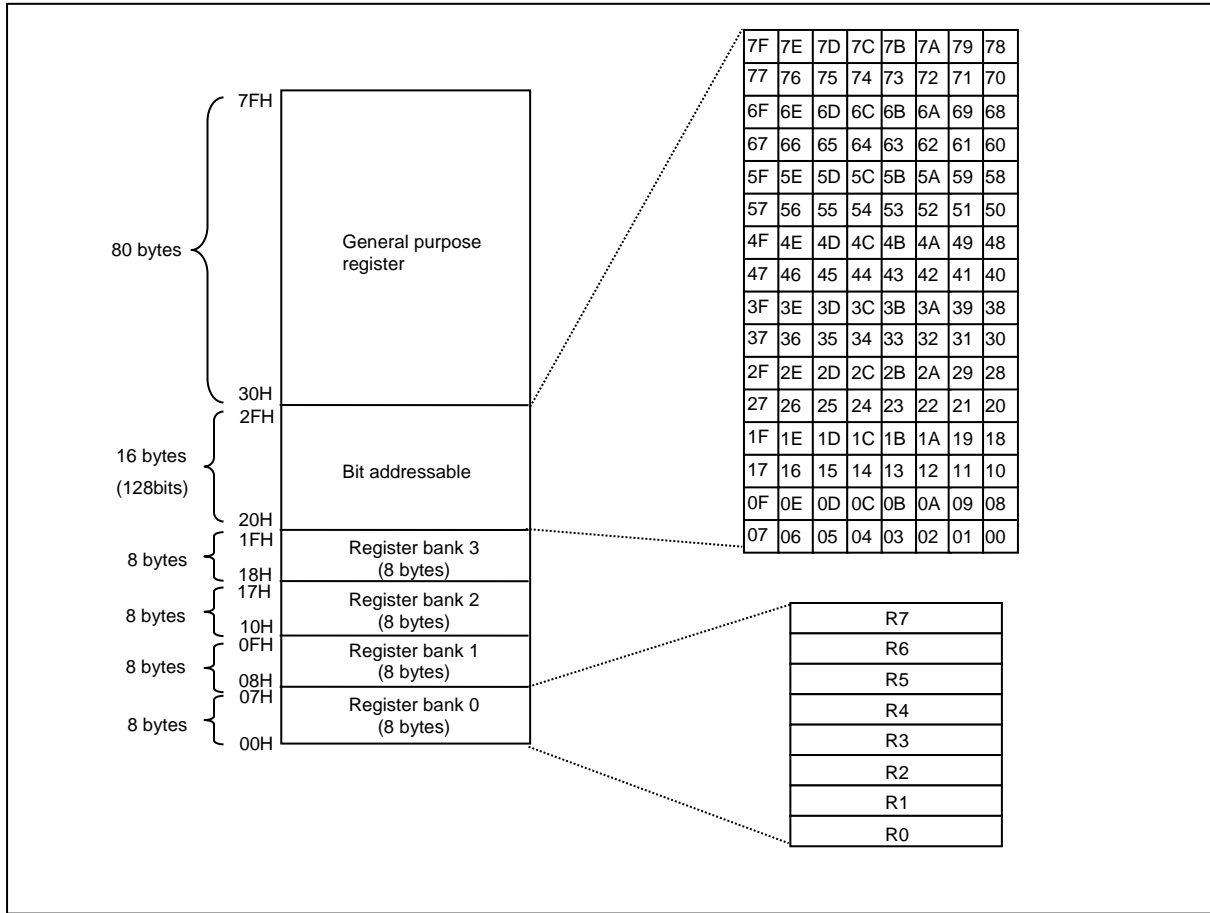

Figure 8-3 Low 128 bytes RAM

8.3 XSFR

MC96FT242 has 1792Bytes XSRAM. This area has no relation with RAM/FLASH. It can read and write through SFR with 8-bit unit.

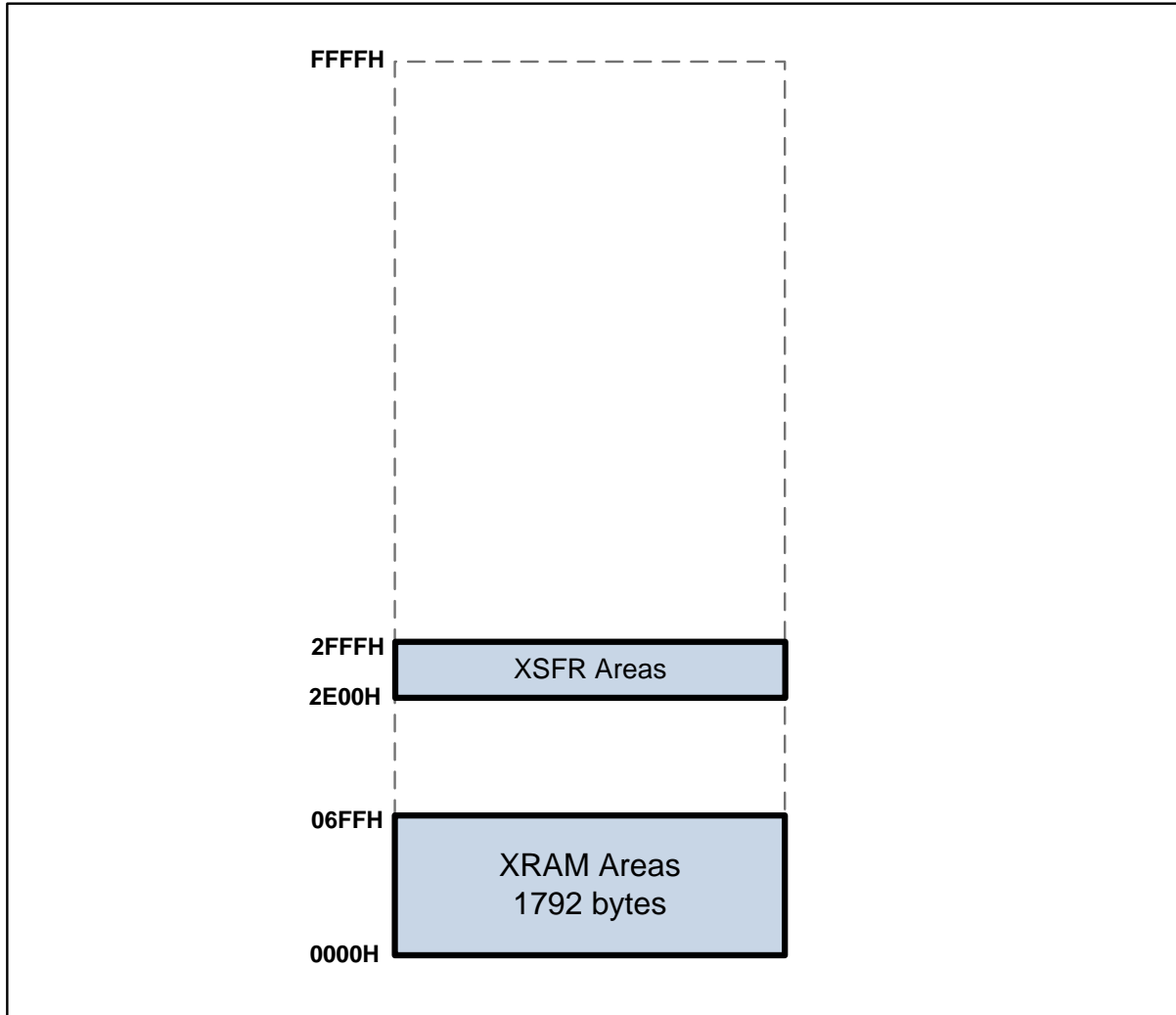

Figure 8-4 XDATA Memory Area

8.4 SFR Map

8.4.1 SFR Map Summary

Table 8-1 SFR Map Summary

	0H/8H ⁽¹⁾	1H/9H	2H/AH	3H/BH	4H/CH	5H/DH	6H/EH	7H/FH
2F58H	FUSE_TOU	FUSE_FLS	FUSE_CAL2	FUSE_CAL1	FUSE_CAL0	FUSE_CONF	TEST_REGB	TEST_REGA
2EC8H	FPCAL	VCAL	CCAL	TSCTL0	TSCTL1	P0FT	P2FT	P3FT
2EC0H	TTMR	TTDLL	TTDLH	TTDHL	TTDHH	KENR	KSMR	
2E50H	RSD20	RSD21	RSD22	RSD23	RSD24	RSD25	RSD26	RSD27
2E48H	RSD10	RSD11	RSD12	RSD13	RSD14	RSD15	RSD16	RSD17
2E40H	RSD00	RSD01	RSD02	RSD03	RSD04	RSD05	RSD06	RSD07
2E28H	KS24H	KS24L	KS25H	KS25L	KS26H	KS26L	KS27H	KS27L
2E20H	KS20H	KS20L	KS21H	KS21L	KS22H	KS22L	KS23H	KS23L
2E18H	KS14H	KS14L	KS15H	KS15L	KS16H	KS16L	KS17H	KS17L
2E10H	KS10H	KS10L	KS11H	KS11L	KS12H	KS12L	KS13H	KS13L
2E08H	KS04H	KS04L	KS05H	KS05L	KS06H	KS06L	KS07H	KS07L
2E00H	KS00H	KS00L	KS01H	KS01L	KS02H	KS02L	KS03H	KS03L
F8H	IP1	-	UCTRL1	UCTRL2	UCTRL3	USTAT	UBAUD	UDATA
F0H	B	-	FEARL	FEARM	FEARH	FEDR	FETR	-
E8H	-	-	FEMR	FECR	FESR	FETCR	-	-
E0H	ACC	-	TSCR	TSTR	-	-	-	-
D8H	-	-	I2CMR	I2CSR	I2CSCLLR	I2CSCLHR	I2CSDHR	I2CDR
D0H	PSW	ADCM	ADCM2	ADCR1	ADCRH	-	I2CSAR1	I2CSAR
C8H	-	-	-	FCMR	FCLL	FCLH	FCHL	FCHH
C0H	BUZCR1	BUZDR1	T2CR	T2CR1	PWM2DRL CDR2L / T2L	PWM2DRH CDR2H / T2H	PWM2PRL T2DRL	PWM2PRH T2DRH
B8H	IP	-	T1CR	T1CR1	PWM1DRL CDR1L / T1L	PWM1DRH CDR1H / T1H	PWM1PRL T1DRL	PWM1PRH T1DRH
B0H	BUZCR0	BUZDR0	T0CR	T0CR1	PWM0DRL CDR0L / T0L	PWM0DRH CDR0H / T0H	PWM0PRL T0DRL	PWM0PRH T0DRH
A8H	IE	IE1	IE2	PSR0	PSR1	PSR2	PSR3	PSRPWM
A0H	-	P3IO	EO	PCI0	PC11	-	-	-
98H	P3	P2IO	P2PU	P2OD	P2DB	P3PU	P3OD	P3DB
90H	P2	P1IO	P1PU	P1OD	P1DB	P0PU	P0OD	P0DB
88H	P1	P0IO	SCCR	BCCR	BITR	WDTMR	WDTR /WDTCR	LVDR
80H	P0	SP	DPL	DPH	DPL1	DPH1	BODR	PCON

Note: 1) These registers are bit-addressable

8.4.2 Compiler Compatible SFR

ACC (Accumulator) : E0H

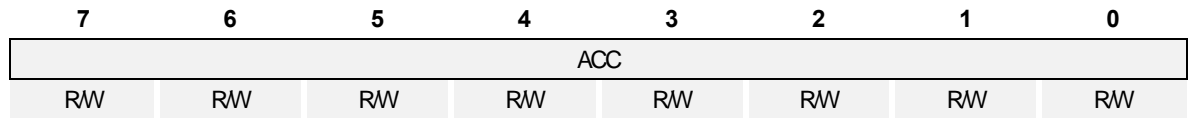

Initial value : 00H

ACC Accumulator

B (B Register) : F0H

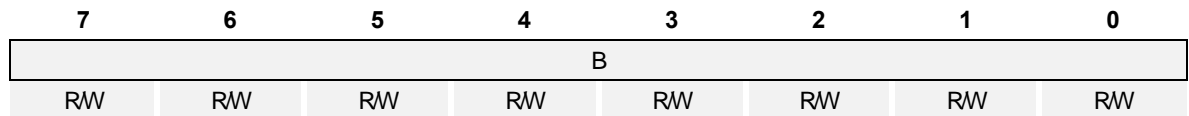

Initial value : 00H

B B Register

SP (Stack Pointer) : 81H

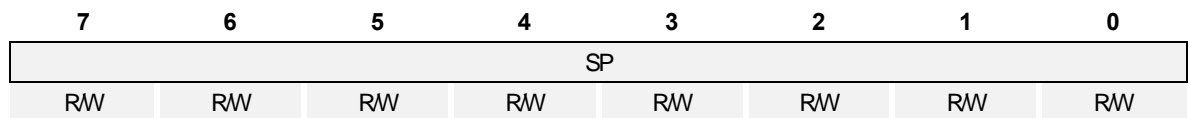

Initial value : 07H

SP Stack Pointer

DPL (Data Pointer Low Byte) : 82H

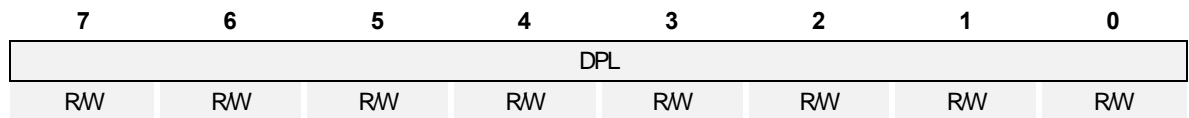

Initial value : 00H

DPL Data Pointer Low Byte

DPH (Data Pointer High Byte) : 83H

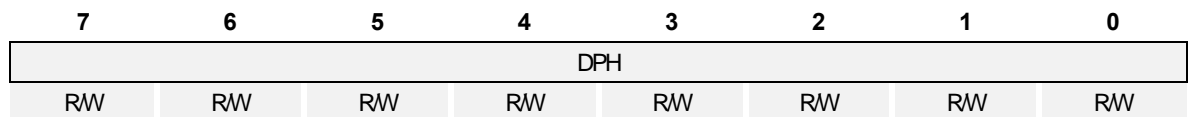

Initial value : 00H

DPH Data Pointer High Byte

DPL1 (Data Pointer Low Byte) : 84H

7	6	5	4	3	2	1	0
DPL							
RW	RW	RW	RW	RW	RW	RW	RW

Initial value : 00H

DPL Data Pointer Low Byte

DPH1 (Data Pointer High Byte) : 85H

7	6	5	4	3	2	1	0
DPH							
RW	RW	RW	RW	RW	RW	RW	RW

Initial value : 00H

DPH Data Pointer High Byte

PSW (Program Status Word) : D0H

7	6	5	4	3	2	1	0
CY	AC	F0	RS1	RS0	OV	F1	P
RW	RW	RW	RW	RW	RW	RW	RW

Initial value : 00H

- CY** Carry Flag
- AC** Auxiliary Carry Flag
- F0** General Purpose User-Definable Flag
- RS1** Register Bank Select bit 1
- RS0** Register Bank Select bit 0
- OV** Overflow Flag
- F1** User-Definable Flag
- P** Parity Flag. Set/cleared by hardware each instruction cycle to indicate an odd/even number of '1' bits in the accumulator

EO (Extended Operation Register) : A2H

7	6	5	4	3	2	1	0
-	-	-	TRAP_EN	-	-	-	DPSEL0
R	R	R	RW	R	R	R	RW

Initial value : 00H

- TRAP_EN** Select the instruction
 - 0 Select MOVC @(DPTR++), A
 - 1 Select Software TRAP instruction
- DPSEL** Select Banked Data Point Register
 - 0 DPTR0
 - 1 DPTR1

9. I/O Ports

9.1 I/O Ports

The MC96FT242 has 30 I/O ports (P0 ~ P3). Each port can be easily configured by software as I/O pin, internal pull up and open drain pin to meet various system configurations and design requirements.

9.2 Port Register

9.2.1 Data Register (P0~P3)

Data Register is a bidirectional I/O port. If ports are configured as output ports, data can be written to the corresponding bit of the Px. If ports are configured as input ports, the data can be read from the corresponding bit of the Px.

9.2.2 Direction Register (P0IO~P3IO)

Each I/O pin can independently used as an input or an output through the PxIO register. Bits cleared in this read/write register will select the corresponding pin in Px to become an input, setting a bit sets the pin to output. All bits are cleared by a system reset.

9.2.3 Pull-up Resistor Selection Register (P0PU~P3PU)

The on-chip pull-up resistor can be connected to them in 1-bit units with a pull-up resistor selection register (PxPU). The pull-up register selection controls the pull-up resistor enable/disable of each port. When the corresponding bit is 1, the pull-up resistor of the pin is enabled. When 0, the pull-up resistor is disabled. All bits are cleared by a system reset.

9.2.4 Open-drain Selection Register (P0OD~P3OD)

There is internally open-drain selection register (PxOD) in P0 ~ P3. The open-drain selection register controls the open-drain enable/disable of each port. Ports become push-pull by a system reset. You should connect an internal resistor or an external resistor in open-drain output mode.

9.2.5 De-bounce Enable Register (P0DB~P3DB)

P0 ~ P3 support de-bounce function. De-bounce time of each ports has 5us

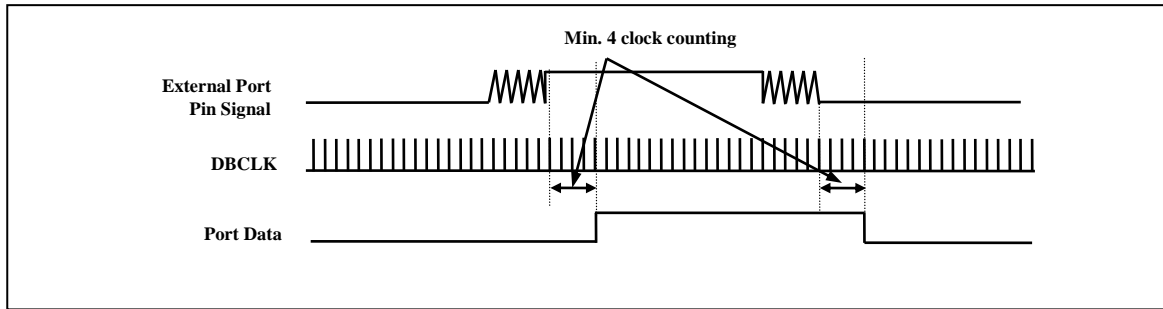

Figure 9-1 Debounce Function

9.2.6 Pin Change Interrupt Enable Register (PCI0~PCI1)

The P0~P1 can support Pin Change Interrupt function. Pin Change Interrupts PCI will trigger if any enabled P0[7:0], P1[5:0] pin toggles. The PCI0, PCI1 Register control which pins contribute to the pin change interrupts.

The pin change interrupt on P0, P1 ports receive the both edge (posedge and negedge) interrupt request as shown in Figure 9-2. Also each pin change interrupt source has enable setting bits. The P0, P1 (data register) register provides the status of ports change interrupts.

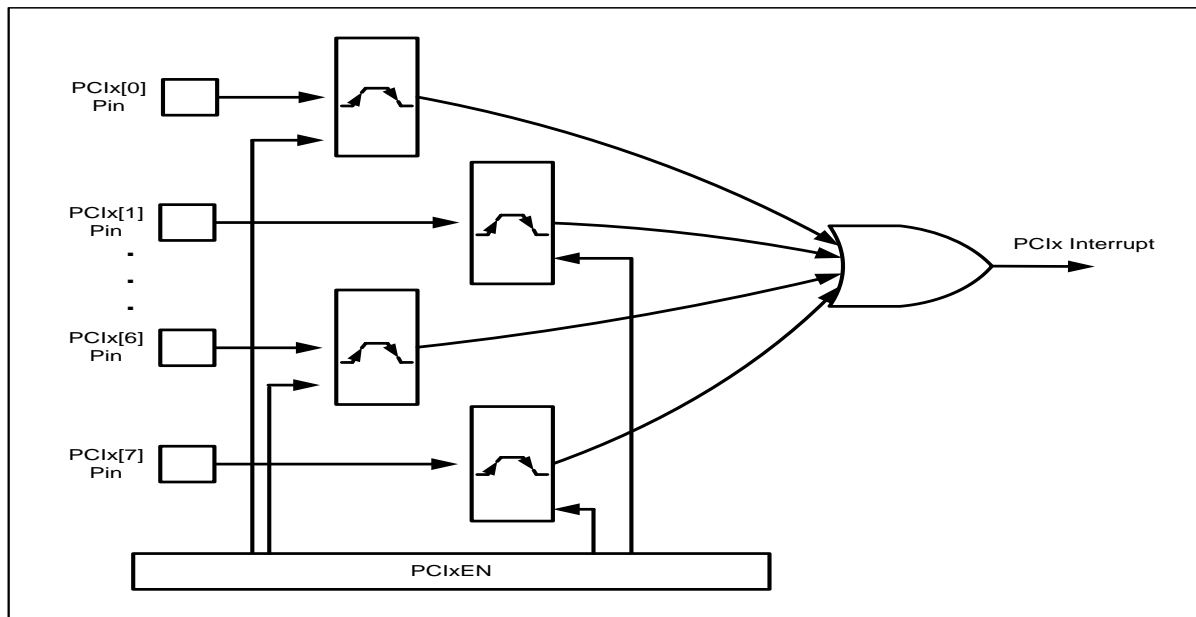

Figure 9-2 Pin Change Interrupt Description

9.2.7 Port Selection Register PSR0,1,2,3, PSRpwm

9.2.7.1 Port Selection Register (PSR0,2,3)

PSR0,2,3 registers prevent the input leakage current when ports are connected to analog inputs. If the bit of PSRx is '1', the dynamic current path of the schmitt OR gate of the port is cut off and the digital input of the corresponding port is always '1'.

9.2.7.2 Special function Port Selection Register (PSR1)

The bit of PSR1[0] is '0', I²C SCL/SDA use P11/P10

The bit of PSR1[0] is '1', I²C SCL/SDA use P14/P13

The bit of PSR1[1] is '0', USART RXD/TXD use P10/P11

The bit of PSR1[1] is '1', USART RXD/TXD use P13/P14

9.2.7.3 Special function Port Selection Register (PSRPWM)

The bit of PSRPWM[2:0] is 0x00 , PWM0 Out P06(Default)

The bit of PSRPWM[2:0] is 0x01 , PWM0 Out P20

The bit of PSRPWM[2:0] is 0x02 , PWM0 Out P22

The bit of PSRPWM[2:0] is 0x03 , PWM0 Out P24

The bit of PSRPWM[2:0] is 0x04 , PWM0 Out P26

The bit of PSRPWM[5:3] is 0x00 , PWM1 Out P15(Default)

The bit of PSRPWM[5:3] is 0x01 , PWM1 Out P21

The bit of PSRPWM[5:3] is 0x02 , PWM1 Out P23

The bit of PSRPWM[5:3] is 0x03 , PWM1 Out P25

The bit of PSRPWM[5:3] is 0x04 , PWM1 Out P27

9.2.8 Register Map

Table 9-1 Register Map

Name	Address	Dir	Default	Description
P0	80H	R/W	00H	P0 Data Register
P0IO	89H	R/W	00H	P0 Direction Register
P0PU	95H	R/W	00H	P0 Pull-up Resistor Selection Register
P0OD	96H	R/W	00H	P0 Open-drain Selection Register
P0DB	97H	R/W	00H	P0 Debounce Enable Register
P1	88H	R/W	00H	P1 Data Register
P1IO	91H	R/W	00H	P1 Direction Register
P1PU	92H	R/W	00H	P1 Pull-up Resistor Selection Register
P1OD	93H	R/W	00H	P1 Open-drain Selection Register
P1DB	94H	R/W	00H	P1 Debounce Enable Register
P2	90H	R/W	00H	P2 Data Register
P2IO	99H	R/W	00H	P2 Direction Register
P2PU	9AH	R/W	00H	P2 Pull-up Resistor Selection Register
P2OD	9BH	R/W	00H	P2 Open-drain Selection Register
P2DB	9CH	R/W	00H	P2 Debounce Enable Register
P3	98H	R/W	00H	P3 Data Register
P3IO	A1H	R/W	00H	P3 Direction Register
P3PU	9DH	R/W	00H	P3 Pull-up Resistor Selection Register
P3OD	9EH	R/W	00H	P3 Open-drain Selection Register
P3DB	9FH	R/W	00H	P3 Debounce Enable Register
PCI0	A3H	R/W	00H	P0 Pin Change Interrupt Enable Register
PCI1	A4H	R/W	00H	P1 Pin Change Interrupt Enable Register
PSR0	ABH	R/W	00H	P0 Port Select Register
PSR1	ACH	R/W	00H	I ² C, USART Port Change Selection Register
PSR2	ADH	R/W	00H	P2 Port Select Register
PSR3	AEH	R/W	00H	P3 Port Select Register
PSRPWM	AFH	R/W	00H	PWM Port Select Register

9.3 P0, P1, P2, P3 Port

9.3.1 Px Port Description

Px is 8-bit I/O port. Px control registers consist of Data register (Px), direction register (PxIO), debounce enable register (PxDB), pull-up register selection register (PxPU), open-drain selection register (PxOD).

9.3.2 Register Description for Px

P0, P1, P2, P3 (Px Data Register) : 80H, 88H, 90H, 98H

7	6	5	4	3	2	1	0
Px7	Px6	Px5	Px4	Px3	Px2	Px1	Px0
R/W	R/W	R/W	R/W	R/W	R/W	R/W	R/W

Initial value : 00H

Px[7:0] I/O Data

P0IO, P1IO, P2IO, P3IO(Px Direction Register) : 89H, 91H, 99H, A1H

7	6	5	4	3	2	1	0
Px7IO	Px6IO	Px5IO	Px4IO	Px3IO	Px2IO	Px1IO	Px0IO
R/W	R/W	R/W	R/W	R/W	R/W	R/W	R/W

Initial value : 00H

PxIO[7:0] Px data I/O direction.
 0 Input
 1 Output

P0PU, P1PU, P2PU, P3PU (Px Pull-up Resistor Selection Register) : 95H, 92H, 9AH, 9DH

7	6	5	4	3	2	1	0
Px7PU	Px6PU	Px5PU	Px4PU	Px3PU	Px2PU	Px1PU	Px0PU
R/W	R/W	R/W	R/W	R/W	R/W	R/W	R/W

Initial value : 00H

PxPU[7:0] Configure pull-up resistor of Px port
 0 Disable
 1 Enable

P0OD, P1OD, P2OD, P3OD (Px Open-drain Selection Register) : 96H, 93H, 9BH, 9EH

7	6	5	4	3	2	1	0
Px7OD	Px6OD	Px5OD	Px4OD	Px3OD	Px2OD	Px1OD	Px0OD
R/W	R/W	R/W	R/W	R/W	R/W	R/W	R/W

Initial value : 00H

PxOD[7:0] Configure open-drain of Px port
 0 Disable
 1 Enable

P0DB, P1DB, P2DB, P3DB (Px Debounce Enable Register) : 97H, 94H, 9CH, 9FH

7	6	5	4	3	2	1	0
Px7DB	Px6DB	Px5DB	Px4DB	Px3DB	Px2DB	Px1DB	Px0DB
R/W	R/W	R/W	R/W	R/W	R/W	R/W	R/W

Initial value : 00H

PxDB[7:0] Configure debounce of Px port
 0 Disable
 1 Enable

PCI0 (P0 Pin Change Interrupt Enable Register) : A3H

7	6	5	4	3	2	1	0
PCI07	PCI06	PCI05	PCI04	PCI03	PCI02	PCI01	PCI00
R/W	R/W	R/W	R/W	R/W	R/W	R/W	R/W

Initial value: 00H

PCI0[7:0] Pin change interrupt input of P0 port
0 Disable
1 Enable

PCI1 (P1 Pin Change Interrupt Enable Register) : A4H

7	6	5	4	3	2	1	0
-	-	PCI15	PCI14	PCI13	PCI12	PCI11	PCI10
-	-	R/W	R/W	R/W	R/W	R/W	R/W

Initial value: 00H

PCI1[5:0] Pin change interrupt input of P1 port
0 Disable
1 Enable

PSR0,2,3 registers prevent the input leakage current when ports are connected to analog inputs (ADC input) or outputs (TOUCH scan wave output). If the bit of PSR0,2,3 is '1', the dynamic current path of the schmitt OR gate of the port is cut off and the digital input of the corresponding port is always '1'.

PSR0 (P0 Ports leakage prevent Register) : ABH

7	6	5	4	3	2	1	0
PSR07	PSR06	PSR05	PSR04	PSR03	PSR02	PSR01	PSR00
R/W	R/W	R/W	R/W	R/W	R/W	R/W	R/W

Initial value : 00H

PSR0[7:0] P07~P00 ports leakage prevent register
0 Disable leakage prevent function (default)
1 Enable leakage prevent function for TOUCH

PSR1 (I²C, USART Ports Change Selection Register) : ACH

7	6	5	4	3	2	1	0
-	-	-	-	-	-	PSR11	PSR10
-	-	-	-	-	-	R/W	R/W

Initial value : 00H

PSR1[1] USART ports selection register
0 P10, P11 for USART (default)
1 P13, P14 for USART

PSR1[0] I²C ports selection register
0 P10, P11 for I²C (default)
1 P13, P14 for I²C

PSR2 (P2 Ports leakage prevent Register) : ADH

7	6	5	4	3	2	1	0
PSR27	PSR26	PSR25	PSR24	PSR23	PSR22	PSR21	PSR20
R/W	R/W	R/W	R/W	R/W	R/W	R/W	R/W

Initial value : 00H

PSR2[7:0] P27~P20 port leakage prevent register
 0 Disable leakage prevent function (default)
 1 Enable leakage prevent function for TOUCH or ADC

PSR3 (P3 Ports leakage prevent Register) : AEH

7	6	5	4	3	2	1	0
PSR37	PSR36	PSR35	PSR34	PSR33	PSR32	PSR31	PSR30
R/W	R/W	R/W	R/W	R/W	R/W	R/W	R/W

Initial value : 00H

PSR3[7:0] P37~P30 port leakage prevent register
 0 Disable leakage prevent function (default)
 1 Enable leakage prevent function for TOUCH

PSRPWM (PWM Ports Selection Register) : AFH

7	6	5	4	3	2	1	0
-	-	PSRpwm5	PSRpwm4	PSRpwm3	PSRpwm2	PSRpwm1	PSRpwm0
-	-	R/W	R/W	R/W	R/W	R/W	R/W

Initial value: 00H

PSRpwm[5:3] PWM1 output port select register
 0 0 0 Select P1[5] (default)
 0 0 1 Select P2[1]
 0 1 0 Select P2[3]
 0 1 1 Select P2[5]
 1 0 0 Select P2[7]

PSRpwm[2:0] PWM0 output port select register
 0 0 0 Select P0[6] (Default)
 0 0 1 Select P2[0]
 0 1 0 Select P2[2]
 0 1 1 Select P2[4]
 1 0 0 Select P2[6]

Note : PWM2 output port is only P0[7]

10. Interrupt Controller

10.1 Overview

The MC96FT242 supports up to 18 interrupt sources. The interrupts have separate enable register bits associated with them, allowing software control. They can also have four levels of priority assigned to them. The interrupt controller has following features:

- receive the request from 18 interrupt source
- 6 group priority
- 4 priority levels
- Multi Interrupt possibility
- If the requests of different priority levels are received simultaneously, the request of higher priority level is serviced
- Each interrupt source can control by EA bit and each IEx bit
- Interrupt latency: 5-8 machine cycles in single interrupt system

The maskable interrupts are enabled through five pair of interrupt enable registers (IE, IE1, IE2). Bits of IE, IE1, IE2 register each individually enable/disable a particular interrupt source. Overall control is provided by bit 7 of IE (EA). When EA is set to '0', all interrupts are disabled: when EA is set to '1', interrupts are individually enabled or disabled through the other bits of the interrupt enable registers. The MC96FT242 supports a 4-level priority scheme. Each maskable interrupt is individually assigned to one of four priority levels by writing to IP or IP1.

Priority sets two bit which is to IP and IP1 register about group. If two requests of different priority levels are received simultaneously, the request of higher priority level is serviced. If the request of same or lower priority level is received, that request is not serviced.

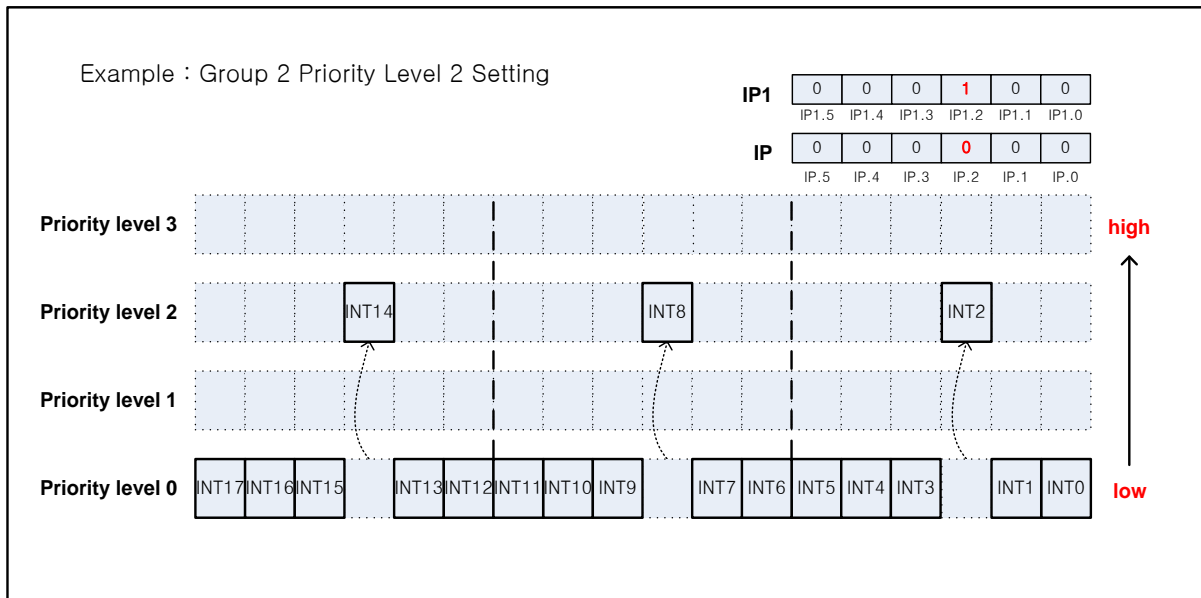

Figure 10-1 Interrupt Group Priority Level

10.2 Block Diagram

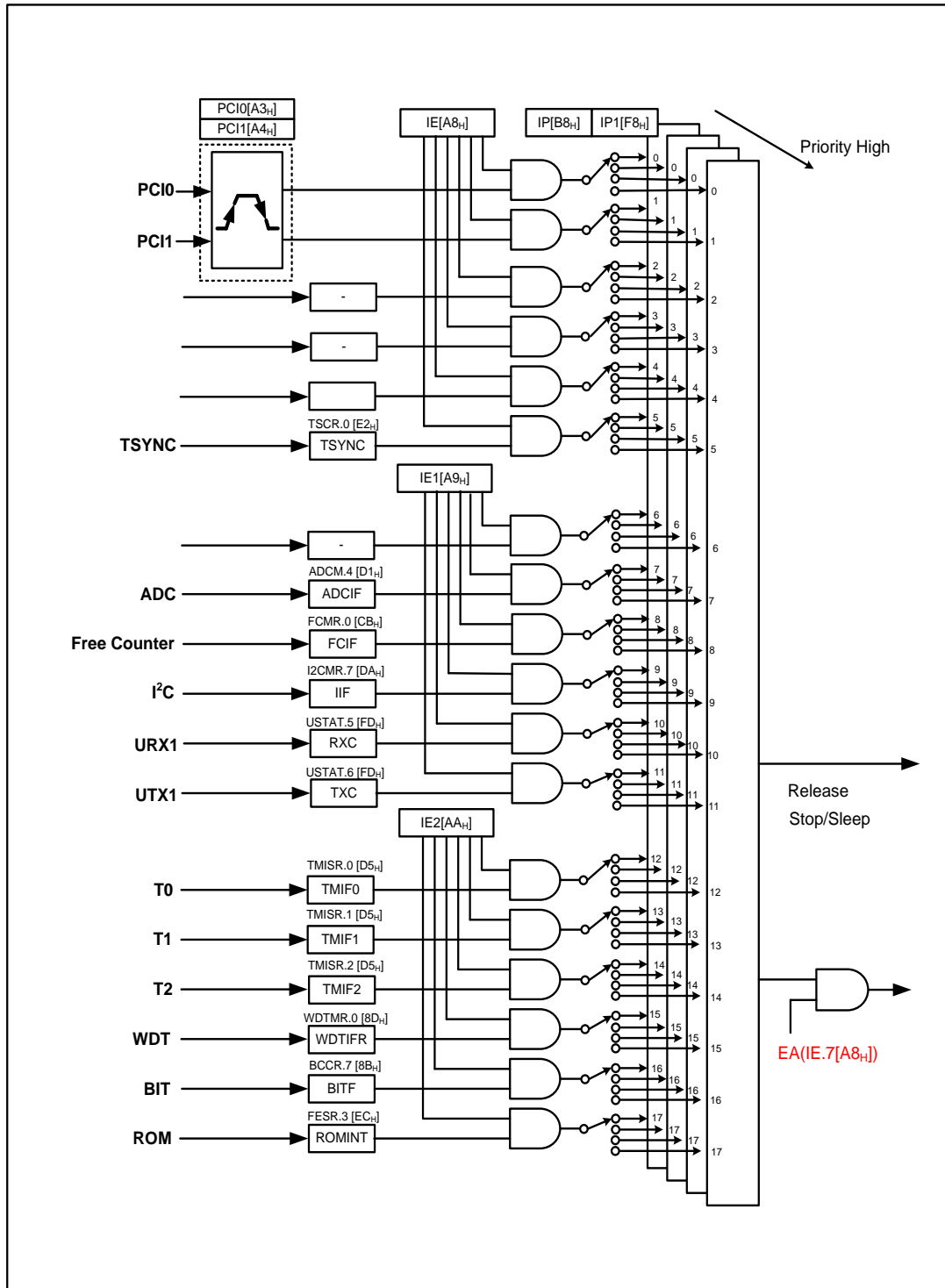

Figure 10-2 Block Diagram of Interrupt

10.3 Interrupt Vector Table

The interrupt controller supports 18 interrupt sources as shown in the Table 10-1 below. When interrupt becomes service, long call instruction (LCALL) is executed in the vector address. Interrupt request 18 has a decided priority order.

Table 10-1 Interrupt Vector Address Table

Interrupt Source	Symbol	Interrupt Enable Bit	Mask	Vector Address
PCI0	INT0	IE0.0	Maskable	0003H
PCI1	INT1	IE0.1	Maskable	000BH
Reserved	INT2	IE0.2	Maskable	0013H
Reserved	INT3	IE0.3	Maskable	001BH
Reserved	INT4	IE0.4	Maskable	0023H
TSYNC	INT5	IE0.4	Maskable	002BH
Reserved	INT6	IE1.0	Maskable	0033H
ADC	INT7	IE1.1	Maskable	003BH
Free Count	INT8	IE1.2	Maskable	0043H
I2C	INT9	IE1.3	Maskable	004BH
USART Rx	INT10	IE1.4	Maskable	0053H
USART Tx	INT11	IE1.5	Maskable	005BH
T0	INT12	IE2.0	Maskable	0063H
T1	INT13	IE2.1	Maskable	006BH
T2	INT14	IE2.2	Maskable	0073H
WDT	INT15	IE2.3	Maskable	007BH
BIT	INT16	IE2.4	Maskable	0083H
FLASH	INT17	IE2.5	Maskable	008BH

For mask-able interrupt execution, first EA bit must set '1' and specific interrupt source must set '1' by writing a '1' to associated bit in the IEx. If interrupt request is received, specific interrupt request flag set '1'. And it remains '1' until CPU accepts interrupt. After that, interrupt request flag will be cleared automatically.

10.4 Interrupt Sequence

An interrupt request is held until the interrupt is accepted or the interrupt latch is cleared to '0' by a reset or an instruction. Interrupt acceptance always generates at last cycle of the instruction. So instead of fetching the current instruction, CPU executes internally LCALL instruction and saves the PC stack. For the interrupt service routine, the interrupt controller gives the address of LJMP instruction to CPU. After finishing the current instruction, at the next instruction to go interrupt service routine needs 5~8 machine cycle and the interrupt service task is terminated upon execution of an interrupt return instruction [RETI]. After generating interrupt, to go to interrupt service routine, the following process is progressed

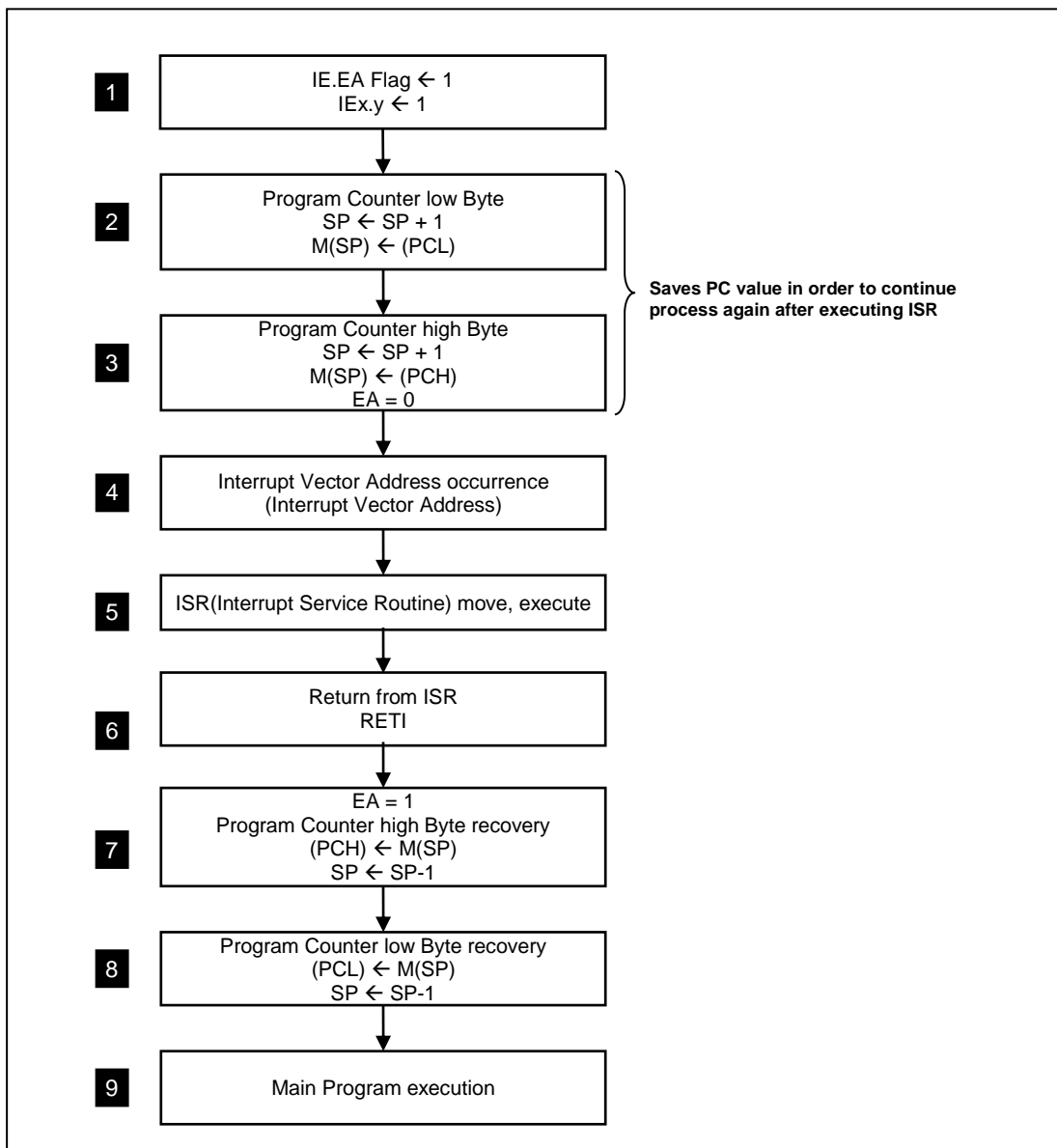

Figure 10-3 Interrupt Sequence Flow

10.5 Effective Timing after Controlling Interrupt bit

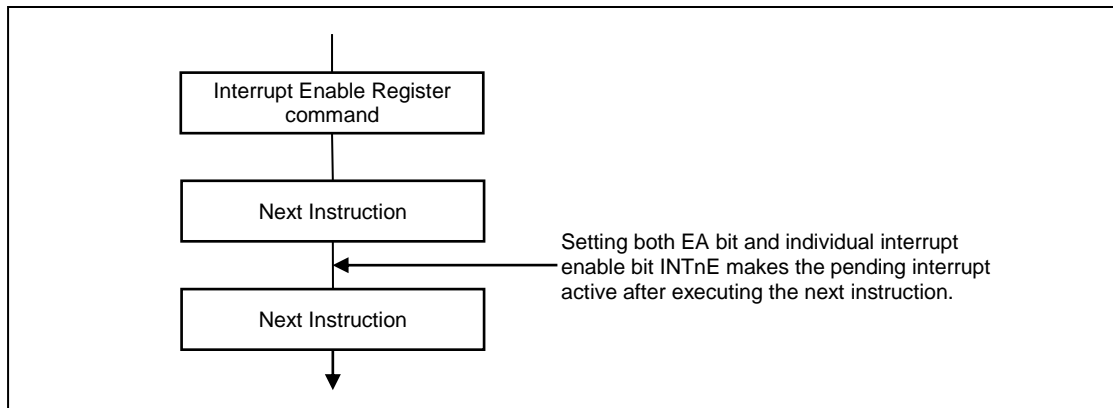

Figure 10-4 Interrupt Enable Register Effective Timing

10.6 Multi Interrupt

If two requests of different priority levels are received simultaneously, the request of higher priority level is serviced. If requests of the interrupt are received at the same time simultaneously, an interrupt polling sequence determines by hardware which request is serviced. However, multiple processing through software for special features is possible.

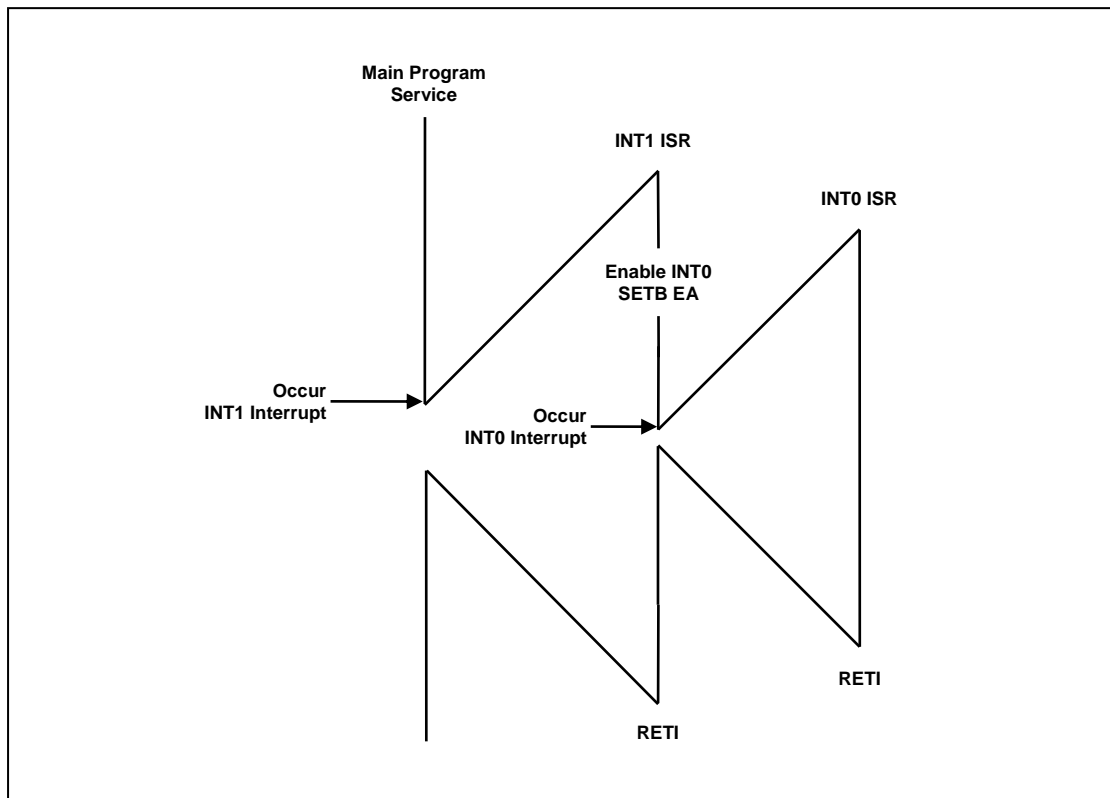

Figure 10-5 Execution of Multi Interrupt

Following example is shown to service INT0 routine during INT1 routine in Figure 10-5. In this

example, INT0 interrupt priority is higher than INT1 interrupt priority. If some interrupt is lower than INT1 priority, it can't service its interrupt routine.

Example) Software Multi Interrupt:

```
INT1:  MOV    IE, #81H    ; Enable INT0 only
        MOV    IE1, #00H ; Disable others
        SETB   EA        ; Enable global interrupt (necessary for multi interrupt)
        :
```

10.7 Interrupt Enable Accept Timing

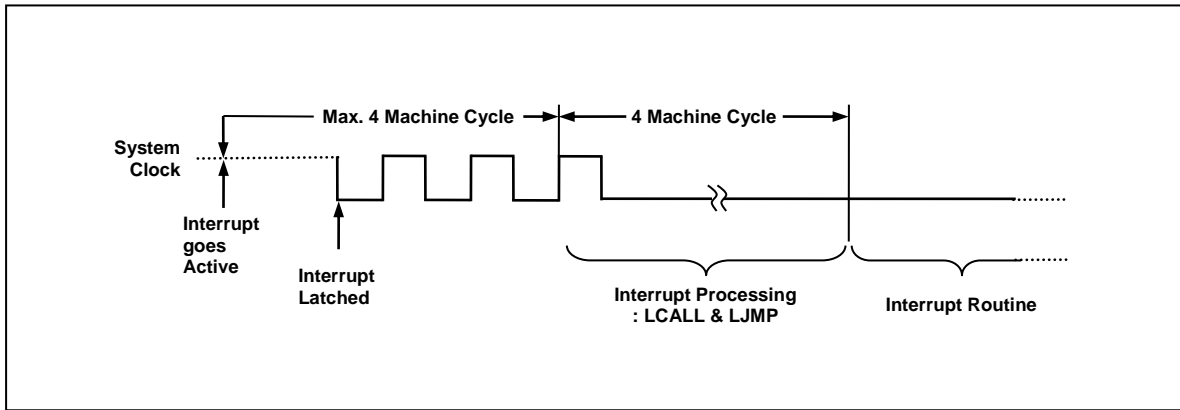

Figure 10-6 Interrupt Response Timing Diagram

10.8 Interrupt Service Routine Address

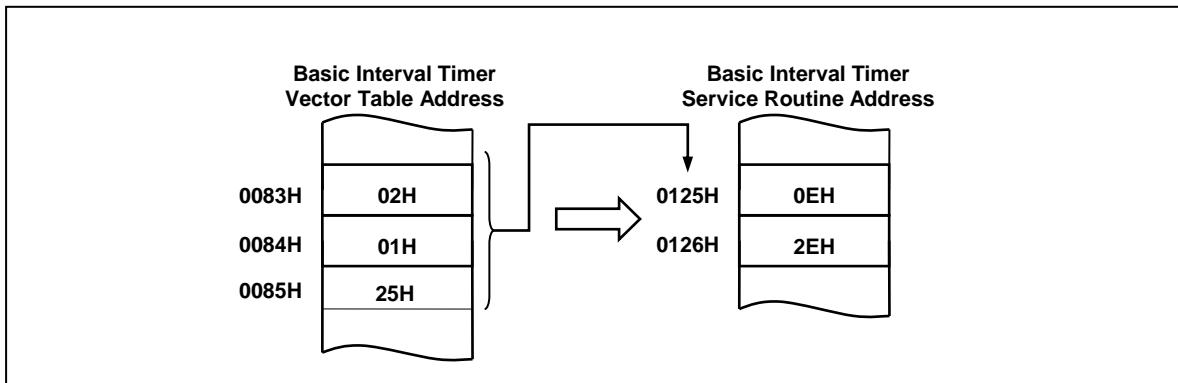

Figure 10-7 Correspondence between Vector Table Address and the Entry Address of ISR

10.9 Saving/Restore General-Purpose Registers

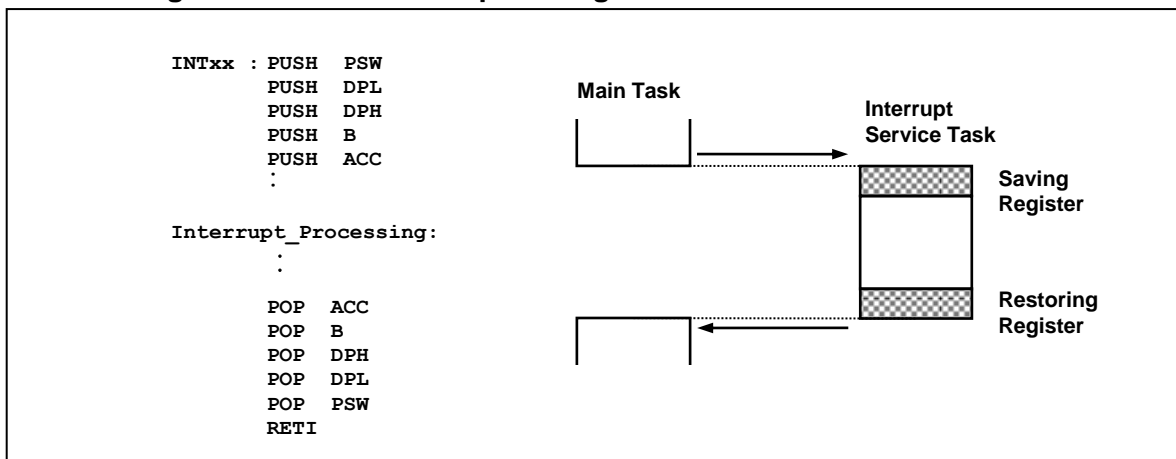

Figure 10-8 Saving/Restore Process Diagram & Sample Source

10.10 Interrupt Timing

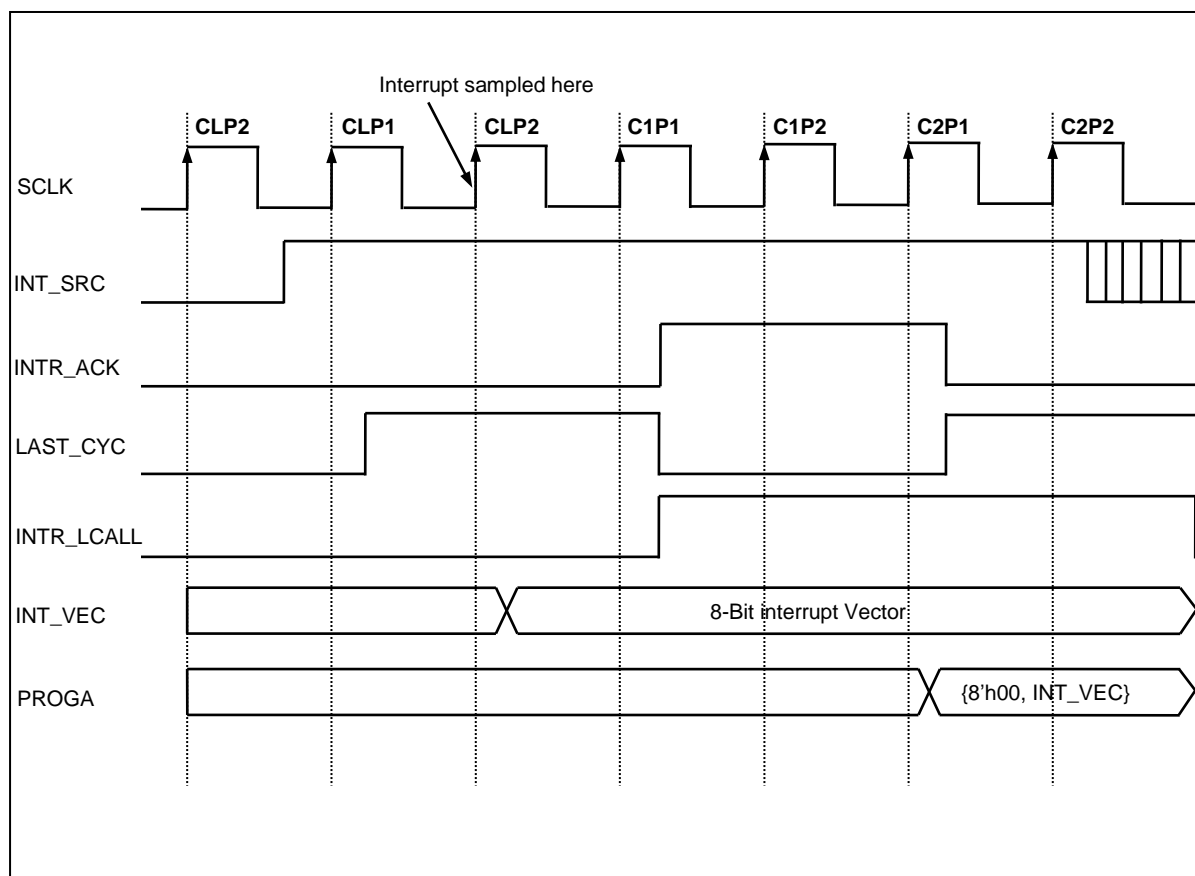

Figure 10-9 Timing chart of Interrupt Acceptance and Interrupt Return Instruction

Interrupt source sampled at last cycle of the command. When sampling interrupt source, it is decided to low 8-bit of interrupt vector. M8051W core makes interrupt acknowledge at first cycle of command, executes long call to jump interrupt routine as INT_VEC.

Note) command cycle C?P? : L=Last cycle, 1=1st cycle or 1st phase, 2=2nd cycle or 2nd phase

10.11 Interrupt Register Overview

10.11.1 Interrupt Enable Register (IE, IE1, IE2)

Interrupt enable register consists of Global interrupt control bit (EA) and peripheral interrupt control bits. Totally 18 peripheral are able to control interrupt.

10.11.2 Interrupt Priority Register (IP, IP1)

The 18 interrupt divides 6 groups which have each 3 interrupt sources. A group can decide 4 levels interrupt priority using interrupt priority register. Level 3 is the high priority, while level 0 is the low priority. Initially, IP, IP1 reset value is '0'. At that initialization, low interrupt number has a higher priority than high interrupt number. If decided the priority, low interrupt number has a higher priority than high interrupt number in that group.

10.11.3 Register Map

Table 10-2 Register Map

Name	Address	Dir	Default	Description
IE	A8H	R/W	00H	Interrupt Enable Register
IE1	A9H	R/W	00H	Interrupt Enable Register 1
IE2	AAH	R/W	00H	Interrupt Enable Register 2
IP	B8H	R/W	00H	Interrupt Priority Register
IP1	F8H	R/W	00H	Interrupt Priority Register 1

10.12 Interrupt Register Description

The Interrupt Register is used for controlling interrupt functions. Also it has pin change interrupt control registers. The interrupt register consists of Interrupt Enable Register (IE), Interrupt Enable Register 1 (IE1), Interrupt Enable Register 2 (IE2), Interrupt Priority Register (IP), Interrupt Priority Register 2 (IP2), P0 Pin Change Interrupt Register (PCI0), and P1 Pin Change Interrupt Enable Register (PC11). The pin change interrupt on P0 and P1 ports receive the bot edge (posedge and negedge) interrupt request.

10.12.1 Register Description for Interrupt

IE (Interrupt Enable Register) : A8H

7	6	5	4	3	2	1	0
EA	-	INT5E	INT4E	INT3E	INT2E	INT1E	INT0E
R/W	-	R/W	R/W	R/W	R/W	R/W	R/W

Initial value : 00H

EA	Enable or disable all interrupt bits
0	All Interrupt disable
1	All Interrupt enable
INT5E	Enable or disable Touch Raw Data Sync Interrupt
0	Disable
1	Enable
INT4E	Reserved
0	Disable
1	Enable
INT3E	Reserved
0	Disable
1	Enable
INT2E	Reserved
0	Disable
1	Enable
INT1E	Enable or disable PCI1

0 Disable
 1 Enable
INT0E Enable or disable PC10
 0 Disable
 1 Enable

IE1 (Interrupt Enable Register 1) : A9H

7	6	5	4	3	2	1	0
-	-	INT11E	INT10E	INT9E	INT8E	INT7E	INT6E
-	-	RW	RW	RW	RW	RW	RW

Initial value : 00H

INT11E Enable or disable UART TX Interrupt
 0 Disable
 1 Enable
INT10E Enable or disable UART RX Interrupt
 0 Disable
 1 Enable
INT9E Enable or disable I²C Interrupt
 0 Disable
 1 Enable
INT8E Enable or disable Free Run Counter
 0 Disable
 1 Enable
INT7E Enable or disable ADC Interrupt
 0 Disable
 1 Enable
INT6E Reserved
 0 Disable
 1 Enable

IE2 (Interrupt Enable Register 2) : AAH

7	6	5	4	3	2	1	0
-	-	INT17E	INT16E	INT15E	INT14E	INT13E	INT12E
-	-	RW	RW	RW	RW	RW	RW

Initial value : 00H

INT17E Enable or disable ROM Interrupt (not for user)
 0 Disable
 1 Enable
INT16E Enable or disable BIT Interrupt
 0 Disable
 1 Enable
INT15E Enable or disable Watch Dog Timer Interrupt
 0 Disable
 1 Enable
INT14E Enable or disable Timer 2 Interrupt

0 Disable
 1 Enable
INT13E Enable or disable Timer 1 Interrupt
 0 Disable
 1 Enable
INT12E Enable or disable Timer 0 Interrupt
 0 Disable
 1 Enable

IP (Interrupt Priority Register) : B8H

7	6	5	4	3	2	1	0
-	-	IP5	IP4	IP3	IP2	IP1	IP0
-	-	RW	RW	RW	RW	RW	RW

Initial value : 00H

IP1 (Interrupt Priority Register 1) : F8H

7	6	5	4	3	2	1	0
-	-	IP15	IP14	IP13	IP12	IP11	IP10
-	-	RW	RW	RW	RW	RW	RW

Initial value : 00H

**IP1[5:0],
 IP[5:0]** Select Interrupt Group Priority

IP1	IP	Description
0	0	level 0 (default : lowest)
0	1	level 1
1	0	level 2
1	1	level 3 (highest)

11. Peripheral Hardware

11.1 Clock Generator

11.1.1 Overview

As shown in Figure 11-1, the clock generator produces the basic clock pulses which provide the system clock to be supplied to the CPU and the peripheral hardware. It contains main-frequency clock oscillator. The default system clock is INT-RC Oscillator and the default division rate is one. In order to stabilize system internally, use 1MHz RING oscillator for BIT, WDT and ports de-bounce.

- Calibrated Internal RC Oscillator (16 MHz)
 - . INT-RC OSC/1 (16 MHz)
 - . INT-RC OSC/2 (8 MHz , Default system clock)
 - . INT-RC OSC/4 (4 MHz)
 - . INT-RC OSC/8 (2 MHz)

11.1.2 Block Diagram

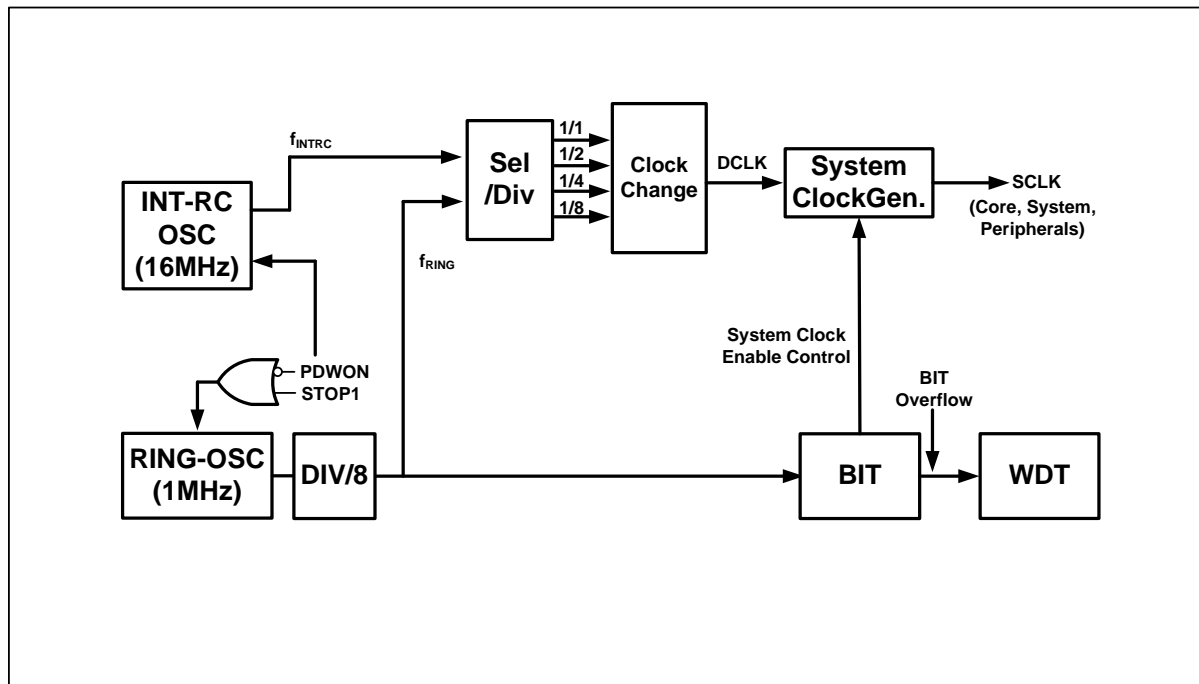

Figure 11-1 Clock Generator Block Diagram

11.1.3 Register Map

Table 11-1 Register Map

Name	Address	Dir	Default	Description
SCCR	8AH	R/W	04H	System and Clock Control Register

11.1.4 Clock Generator Register Description

The Clock Generation Register uses clock control for system operation. The clock generation consists of System and Clock register.

11.1.5 Register Description for Clock Generator

SCCR (System and Clock Control Register) : 8AH

7	6	5	4	3	2	1	0
STOP1	DIV1	DIV0	CBYS	ISTOP	REDUCEC	TestOnly	CS
RW	RW	RW	RW	RW	RW	-	RW

Initial value : 20H

STOP1	Control the STOP Mode Note) When PCON=0x03, This bit is applied. When PCON=0x01, This bit is not applied . 0 STOP2 Mode (at PCON=0x03) (default) 1 STOP1 Mode (at PCON=0x03)															
DIV[1:0]	When using f_{INTRC} as system clock, determine division rate. Note) when using f_{INTRC} as system clock, only division rate come into effect. Note) To change by software, CBYS set to '1' <table> <thead> <tr> <th>DIV1</th> <th>DIV0</th> <th>description</th> </tr> </thead> <tbody> <tr> <td>0</td> <td>0</td> <td>$f_{INTRC}/1$ (16MHz)</td> </tr> <tr> <td>0</td> <td>1</td> <td>$f_{INTRC}/2$ (8MHz)</td> </tr> <tr> <td>1</td> <td>0</td> <td>$f_{INTRC}/4$ (4MHz)</td> </tr> <tr> <td>1</td> <td>1</td> <td>$f_{INTRC}/8$ (2MHz)</td> </tr> </tbody> </table>	DIV1	DIV0	description	0	0	$f_{INTRC}/1$ (16MHz)	0	1	$f_{INTRC}/2$ (8MHz)	1	0	$f_{INTRC}/4$ (4MHz)	1	1	$f_{INTRC}/8$ (2MHz)
DIV1	DIV0	description														
0	0	$f_{INTRC}/1$ (16MHz)														
0	1	$f_{INTRC}/2$ (8MHz)														
1	0	$f_{INTRC}/4$ (4MHz)														
1	1	$f_{INTRC}/8$ (2MHz)														
CBYS	Control the scheme of clock change. If this bit set to '0', clock change is controlled by hardware. But if this set to '1', clock change is controlled by software. Ex) when setting CS, if CBYS bit set to '0', it is not changed right now, CPU goes to STOP mode and then when wake-up, it applies to clock change. Note) when clear this bit, keep other bits in SCCR. 0 Clock changed by hardware during stop mode (default) 1 Clock changed by software															
ISTOP	Control the operation of INT-RC Oscillation Note) when CBYS='1', It is applied 0 RC-Oscillation enable (default) 1 RC-Oscillation disable															
REDUCEC	When STOP1 Mode reduce current 0 Normal current (default) 1 Reduce current															
CS	Determine System Clock Note) by CBYS bit, reflection point is decided <table> <thead> <tr> <th>CS</th> <th>Description</th> </tr> </thead> <tbody> <tr> <td>0</td> <td>f_{INTRC} INTRC (16 MHz)</td> </tr> <tr> <td>1</td> <td>f_{RING} (125 KHz)</td> </tr> </tbody> </table>	CS	Description	0	f_{INTRC} INTRC (16 MHz)	1	f_{RING} (125 KHz)									
CS	Description															
0	f_{INTRC} INTRC (16 MHz)															
1	f_{RING} (125 KHz)															

11.2 BIT

11.2.1 Overview

The MC96FT242 has one 8-bit Basic Interval Timer that is free-run and can't stop. Block diagram is shown in Figure 11-2. In addition, the Basic Interval Timer generates the time base for watchdog timer counting. It also provides a Basic interval timer interrupt (BITF).

The MC96FT242 has these Basic Interval Timer (BIT) features:

- During Power On, BIT gives a stable clock generation time
- On exiting Stop mode, BIT gives a stable clock generation time
- As clock function, time interrupt occurrence

11.2.2 Block Diagram

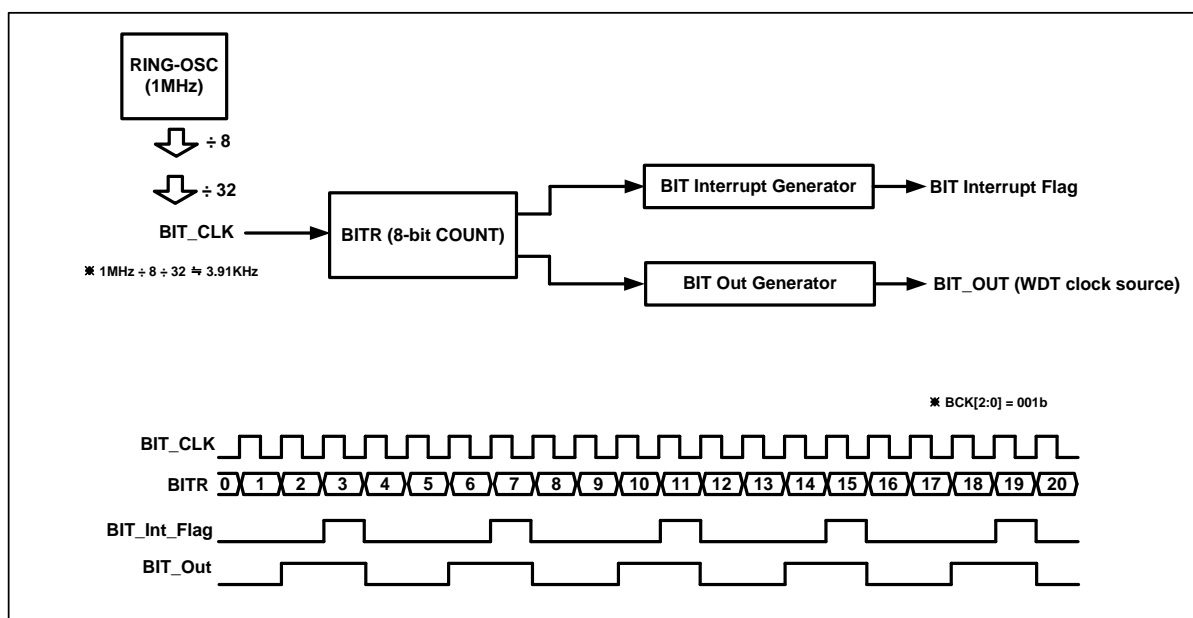

Figure 11-2 BIT Block Diagram

11.2.3 Register Map

Table 11-2 Register Map

Name	Address	Dir	Default	Description
BCCR	8BH	R/W	05H	BIT Clock Control Register
BITR	8CH	R	00H	Basic Interval Timer Register

11.2.4 Bit Interval Timer Register Description

The Bit Interval Timer Register consists of BIT Clock control register (BCCR) and Basic Interval Timer register (BITR). If BCLR bit set to '1', BITR becomes '0' and then counts up. After 1 machine cycle, BCLR bit is cleared as '0' automatically.

11.2.5 Register Description for Bit Interval Timer

BCCR (BIT Clock Control Register) : 8BH

7	6	5	4	3	2	1	0
BITF	-	-	-	BCLR	BCK2	BCK1	BCK0
R/W	R	R	R	R/W	R/W	R/W	R/W

Initial value : 05H

BITF When BIT Interrupt occurs, this bit becomes '1'. For clearing bit, write '0' to this bit.

- 0 no generation
- 1 generation

BCLR If BCLR Bit is written to '1', BIT Counter is cleared as '0'

- 0 Free Running
- 1 Clear Counter

BCK[2:0] Select BIT overflow period (BIT Clock \approx 3.9 KHz)

BCK2	BCK1	BCK0	
0	0	0	0.512msec (BIT Clock * 2)
0	0	1	1.024msec
0	1	0	2.048msec
0	1	1	4.096msec
1	0	0	8.192msec
1	0	1	16.384msec (default)
1	1	0	32.768msec
1	1	1	65.536msec

BITR (Basic Interval Timer Register) : 8CH

7	6	5	4	3	2	1	0
BIT7	BIT6	BIT5	BIT4	BIT3	BIT2	BIT1	BIT0
R	R	R	R	R	R	R	R

Initial value : 00H

BIT[7:0] BIT Counter

11.3 WDT

11.3.1 Overview

The watchdog timer rapidly detects the CPU malfunction such as endless looping caused by noise or the like, and resumes the CPU to the normal state. The watchdog timer signal for detecting malfunction can be selected either a reset CPU or an interrupt request. When the watchdog timer is not being used for malfunction detection, it can be used as a timer to generate an interrupt at fixed intervals. It is possible to use free running 8-bit timer mode (WDTRSON='0') or watch dog timer mode (WDTRSON='1') as setting WDTMR[6] bit. If writing WDTMR[5] to '1', WDT counter value is cleared and counts up. After 1 machine cycle, this bit has '0' automatically. The watchdog timer consists of 8-bit binary counter and the watchdog timer data register. When the value of 8-bit binary counter is equal to the 8 bits of WDTR, the interrupt request flag is generated. This can be used as Watchdog timer interrupt or reset the CPU in accordance with the bit WDTRSON.

The clock source of Watch Dog Timer is BIT overflow output. The interval of watchdog timer interrupt is decided by BIT overflow period and WDTR set value. The equation is as below

$$\text{WDT Interrupt Interval} = (\text{BIT Interrupt Interval}) \times (\text{WDTR Value} + 1)$$

11.3.2 Block Diagram

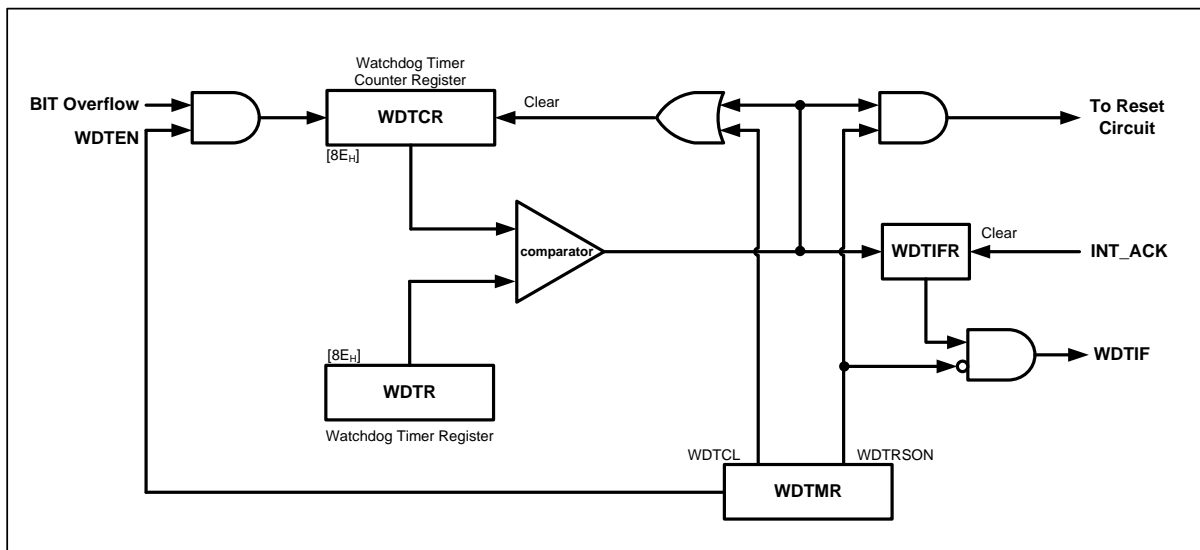

Figure 11-3 WDT Block Diagram

11.3.3 Register Map

Table 11-3 Register Map

Name	Address	Dir	Default	Description
WDTR	8EH	W	FFH	Watch Dog Timer Register
WDTCR	8EH	R	00H	Watch Dog Timer Counter Register
WDTMR	8DH	R/W	00H	Watch Dog Timer Mode Register

11.3.4 Watch Dog Timer Register Description

The Watch dog timer (WDT) Register consists of Watch Dog Timer Register (WDTR), Watch Dog Timer Counter Register (WDTCR) and Watch Dog Timer Mode Register (WDTMR).

11.3.5 Register Description for Watch Dog Timer

WDTR (Watch Dog Timer Register: Write Case) : 8EH

7	6	5	4	3	2	1	0
WDTR7	WDTR6	WDTR5	WDTR4	WDTR3	WDTR2	WDTR1	WDTR0
W	W	W	W	W	W	W	W

Initial value : FFH

WDTR[7:0] Set a period
 $WDT\ Interrupt\ Interval = (BIT\ Interrupt\ Interval) \times (WDTR\ Value + 1)$

Note) To guarantee proper operation, the data should be greater than 01H.

WDTCR (Watch Dog Timer Counter Register: Read Case) : 8EH

7	6	5	4	3	2	1	0
WDTCR7	WDTCR6	WDTCR5	WDTCR4	WDTCR3	WDTCR2	WDTCR1	WDTCR0
R	R	R	R	R	R	R	R

Initial value : 00H

WDTCR[7:0] WDT Counter

WDTMR (Watch Dog Timer Mode Register) : 8DH

7	6	5	4	3	2	1	0
WDTEN	WDTRSON	WDTCL	-	-	-	-	WDTIFR
R/W	R/W	R/W	-	-	-	-	R/W

Initial value : 00H

WDTEN Control WDT operation

0 disable

1 enable

WDTRSON Control WDT Reset operation

0 Free Running 8-bit timer

1 Watch Dog Timer Reset ON

WDTCL Clear WDT Counter

0 Free Run

	1	Clear WDT Counter (auto clear after 1 Cycle)
WDTIFR	When WDT Interrupt occurs, this bit becomes '1'. For clearing bit, write '0' to this bit or auto clear by INT_ACK signal.	
	0	WDT Interrupt no generation
	1	WDT Interrupt generation

11.3.6 WDT Interrupt Timing Waveform

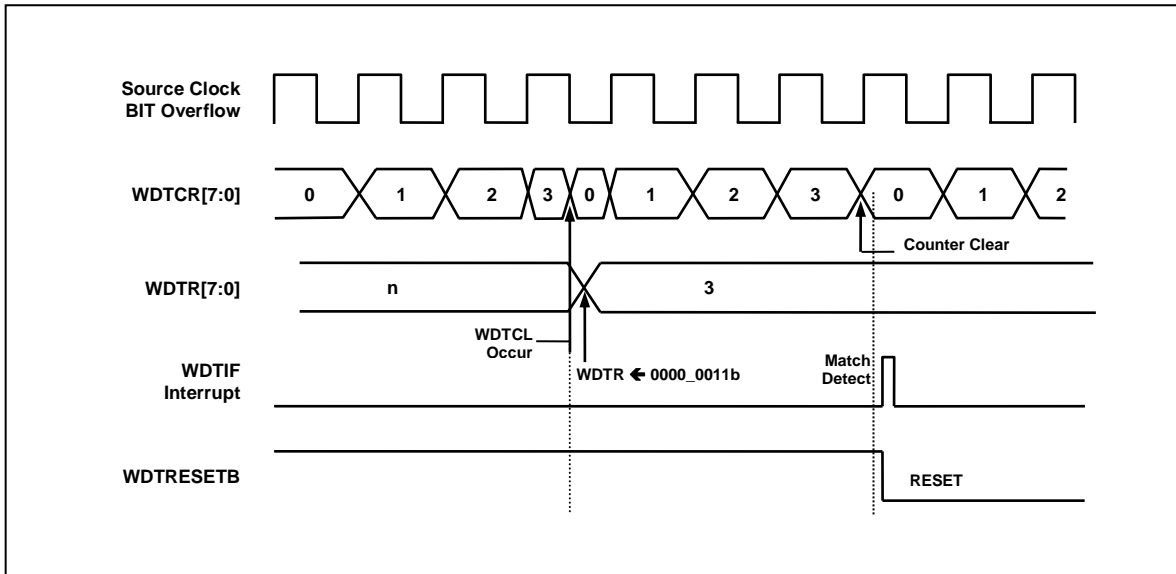

Figure 11-4 WDT Interrupt Timing Waveform

11.4 Free Run Counter

11.4.1 Overview

The clock source of the free run counter is BIT overflow output. The interval of free run counter interrupt is decided by BIT overflow period and 32 bits count value of the four registers. The counter value is the 32 bits value (unsigned long type) and stored to the four registers to easily read. The four registers are (MSB) FCHH, FCHL, FCLH, & FCLL (LSB). If the free run counter starts counting, counter value will be increased with 1 from 0x00000000 to 0xFFFFFFFF. If the counter value is 0xFFFFFFFF, it will be reset to 0x00000000 and continue the counting eternally. If the count period is about 1ms, the full counting time will be about 49 days.

When the count value becomes 0xFFFFFFFF, the interrupt request flag is generated (Option). If the free run counter is not needed, reset the FCEN bit of the Free Run Counter Enable Register (FCMR) to be disable the free run counter.

11.4.2 Block Diagram

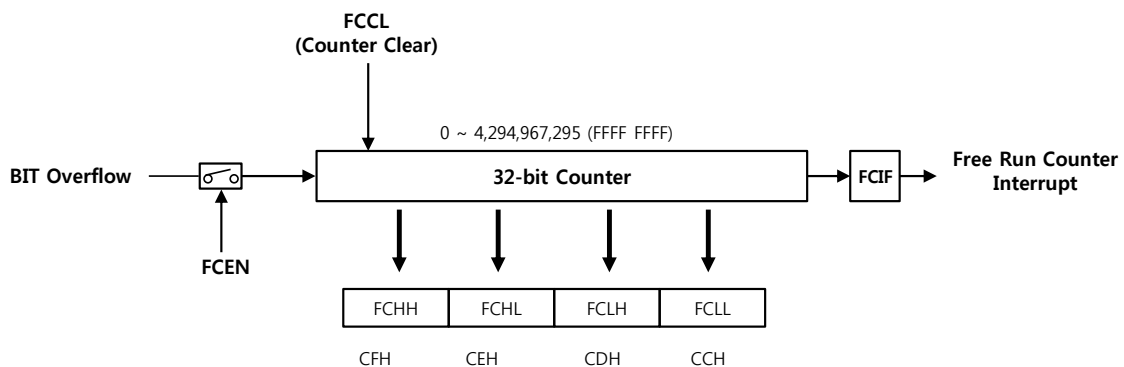

Figure 11-5 Free Run Counter Block Diagram

11.4.3 Register Map

Table 11-4 Register Map

이름	어드레스	방향	Initial value	설명
FCMR	CBH	R/W	00H	Free Run Counter Enable Register
FCLL	CCH	R	00H	Free Run Counter Low L
FCLH	CDH	R	00H	Free Run Counter Low H
FCHL	CEH	R	00H	Free Run Counter High L
FCHH	CFH	R	00H	Free Run Counter High H

11.4.4 Free Run Counter Register Description

Free Run Counter consists of Free Run Counter Enable Register (FCMR), Free Run Counter Register (FCHH, FCHL, FCLH, FCLL).

11.4.5 Register Description for Free Run Counter

FCMR (Free Run Counter Enable Register) : CBH

7	6	5	4	3	2	1	0
FCEN	FCCL	-	-	-	-	-	FCIF
W/R	W						W/R

Initial value : 00H

- FCEN** Free Run Counter Operation Control
 0 Free Run Counter Disable (Default)
 1 Free Run Counter Enable
- FCCL** Free Run Counter Clear
- FCIF** Free Run Counter Interrupt Flag
 0 No Free Run Counter Interrupt
 1 Free Run Counter interrupt occurred, write "0" to clear interrupt flag

FCLL (Free Run Counter Low L) : CCH

7	6	5	4	3	2	1	0
FCLL7	FCLL6	FCLL5	FCLL4	FCLL3	FCLL2	FCLL1	FCLL0
R	R	R	R	R	R	R	R

Initial value : 00H

FCLL[7:0] Free Run Counter Low L

FCLH (Free Run Counter Low H) : CDH

7	6	5	4	3	2	1	0
FCLH7	FCLH6	FCLH5	FCLH4	FCLH3	FCLH2	FCLH1	FCLH0
R	R	R	R	R	R	R	R

Initial value : 00H

FCLH[7:0] Free Run Counter Low H

FCHL (Free Run Counter High L) : CEH

7	6	5	4	3	2	1	0
FCHL7	FCHL6	FCHL5	FCHL4	FCHL3	FCHL2	FCHL1	FCHL0
R	R	R	R	R	R	R	R

Initial value : 00H

FCHL[7:0] Free Run Counter High L

FCHH (Free Run Counter High H) : CFH

7	6	5	4	3	2	1	0
FCHH7	FCHH6	FCHH5	FCHH4	FCHH3	FCHH2	FCHH1	FCHH0
R	R	R	R	R	R	R	R

Initial value : 00H

FCHH[7:0] Free Run Counter High H

11.5 Buzzer Driver

11.5.1 Overview

The Buzzer consists of 8-bit Counter and Buzzer Data Registers (BUZDR0, BUZDR1), Buzzer Control Register (BUZCR0, BUZCR1). The Square Wave (122.07Hz~250KHz @16MHz or 61.035Hz~125KHz, @8MHz) gets out of P06/BUZ0 or P15/BUZ1 pin. BUZDRx (Buzzer Data Registers) controls the Buzzer frequency (look at the following expression). In the BUZCRx (Buzzer Control Register), BUCK[1:0] selects source clock divided from prescaler.

$$f_{\text{BUZ}}(\text{Hz}) = \frac{\text{Oscillator Frequency}}{2 \times \text{Prescaler Ratio} \times (\text{BUZDR} + 1)}$$

Table 11-5 Buzzer Frequency at 16MHz

BUZDRx[7:0]	Buzzer Frequency (kHz)			
	BUZCRx[2:1]=00	BUZCRx[2:1]=01	BUZCRx[2:1]=10	BUZCRx[2:1]=11
0000_0000	250kHz	125.00kHz	62.50kHz	31.250kHz
0000_0001	125kHz	62.50kHz	31.25kHz	15.625kHz
...
1111_1101	984.252Hz	492.126Hz	246.063Hz	123.031Hz
1111_1110	980.392Hz	490.196Hz	245.098Hz	122.549Hz
1111_1111	976.563Hz	488.281Hz	244.141Hz	122.070Hz

11.5.2 Block Diagram

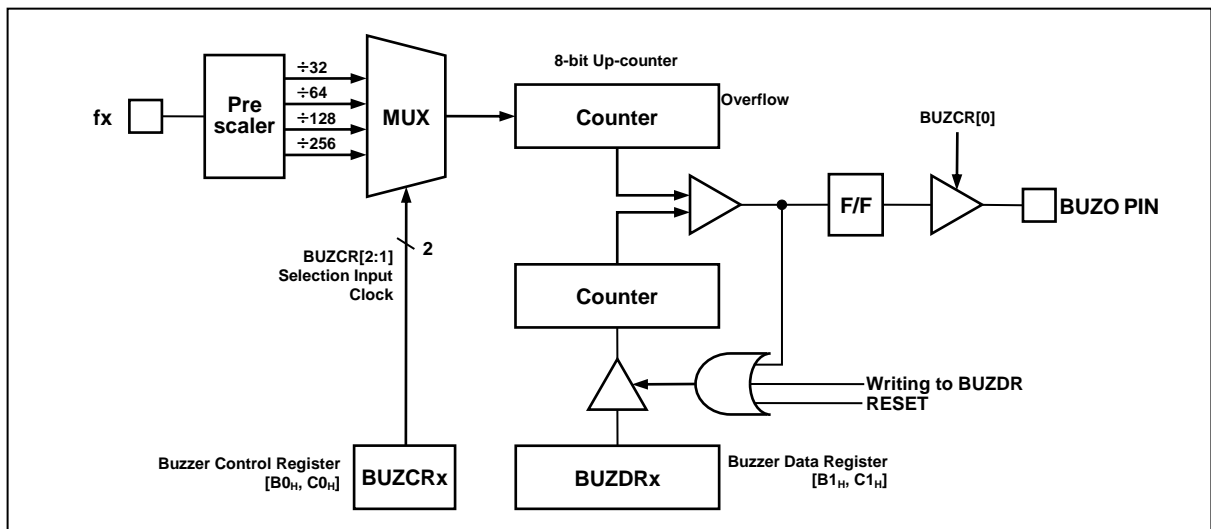

Figure 11-6 Buzzer Driver Block Diagram

11.5.3 Register Map

Table 11-6 Register Map

Name	Address	Dir	Default	Description
BUZCR0	B0H	R/W	00H	Buzzer Control Register 0
BUZDR0	B1H	R/W	FFH	Buzzer Data Register 0
BUZCR1	C0H	R/W	00H	Buzzer Control Register 1
BUZDR1	C1H	R/W	FFH	Buzzer Data Register 1

11.5.4 Buzzer Driver x Register Description

Buzzer Driver consists of Buzzer Data x Register (BUZDR0, BUZDR1), Buzzer Control x Register (BUZCR0, BUZCR1).

11.5.5 Register Description for Buzzer Driver

BUZCR0, BUZCR1 (Buzzer Control 0~1 Register) : B0H, B1H

7	6	5	4	3	2	1	0
-	-	-	-	-	BUCK1	BUCK0	BUZEN
-	-	-	-	-	R/W	R/W	R/W

Initial value : 00H

BUCK[1:0] Buzzer Driver Source Clock Selection
 BUCK1 BUCK0 Source Clock
 0 0 fx/32
 0 1 fx/64
 1 0 fx/128
 1 1 fx/256

BUZEN Buzzer Driver Operation Control
 0 Buzzer Driver disable
 1 Buzzer Driver enable

Note) fx: Main system clock oscillation frequency

BUZDR0, BUZDR1 (Buzzer Data 0~1 Register) : B1H, C1H

7	6	5	4	3	2	1	0
BUZDR7	BUZDR6	BUZDR5	BUZDR4	BUZDR3	BUZDR2	BUZDR1	BUZDR0
R/W	R/W	R/W	R/W	R/W	R/W	R/W	R/W

Initial value : FFH

BUZDR[7:0] This bits control the Buzzer frequency
 Its resolution is 00H ~ FFH

11.6 Timer/PWM

11.6.1 16-bit Timer/Event Counter 0, 1, 2

11.6.1.1 Overview

The 16-bit timer x consists of Multiplexer, Timer Data Register High/Low, Timer Register High/Low, Timer Mode Control Register, PWM Duty High/Low, PWM Period High/Low Register. It is able to use internal 16-bit timer/counter without a port output function.

The 16-bit timer x is able to use the divided clock of the main clock selected from prescaler output.

11.6.1.2 16-Bit Timer/Counter Mode

In the 16-bit Timer/Counter Mode, if the TxH + TxL value and the TxDRH + TxDRL value are matched, Tx/PWMx port outputs. The output is 50:50 of duty square wave, the frequency is following

$$f_{COMP} = \frac{\text{TimerClock Frequency}}{2 \times \text{PrescalerValue} \times (\text{TxDR} + 1)}$$

f_{COMP} is timer output frequency and TxDR is the 16 bits value of TxDRH and TxDRL.

To export the compare output as Tx/PWMx, the Tx_PE bit in the TxCR1 register must set to '1'.

The 16-bit Timer/Counter Mode is selected by control registers as shown in Figure 11-7.

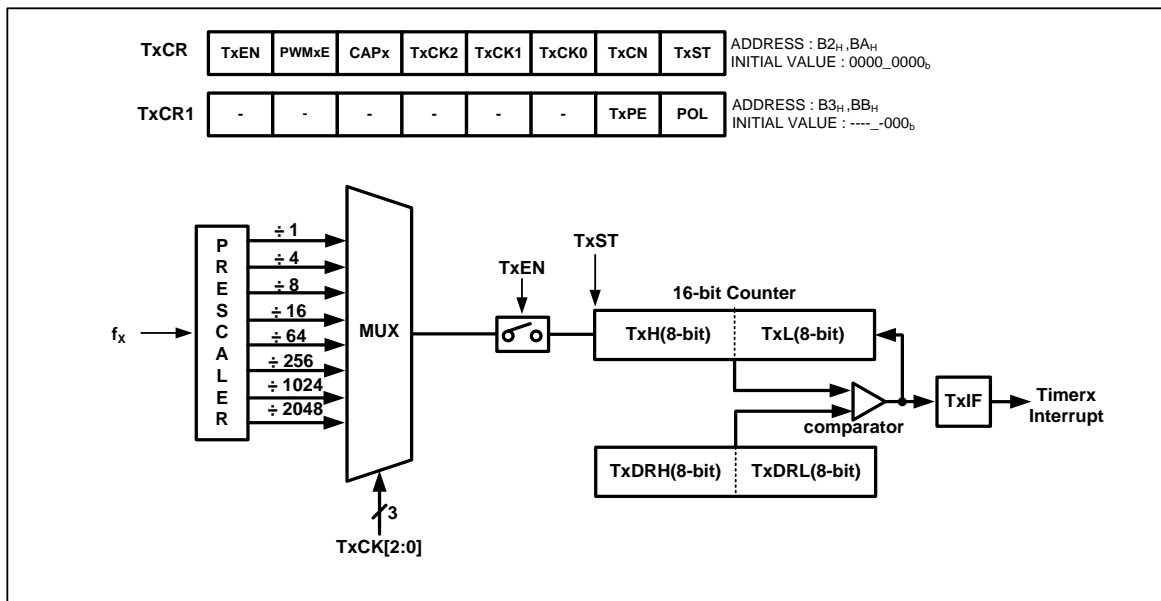

Figure 11-7 Timer x 16-bit Mode Block Diagram

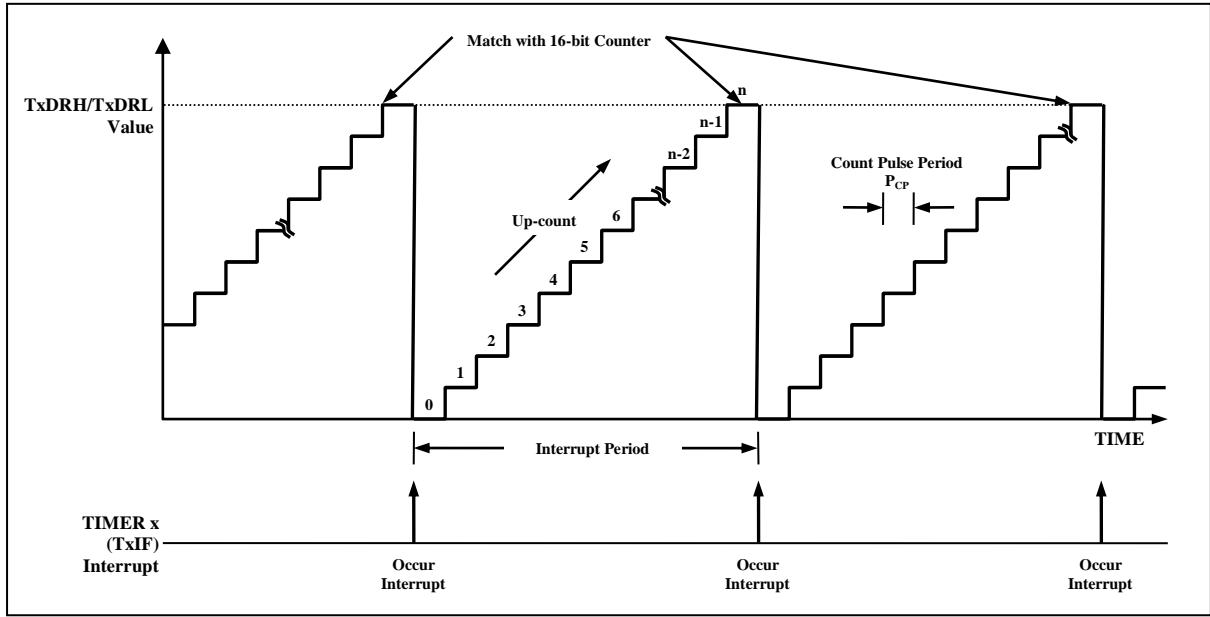

Figure 11-8 Interrupt of Timer/Counter Mode

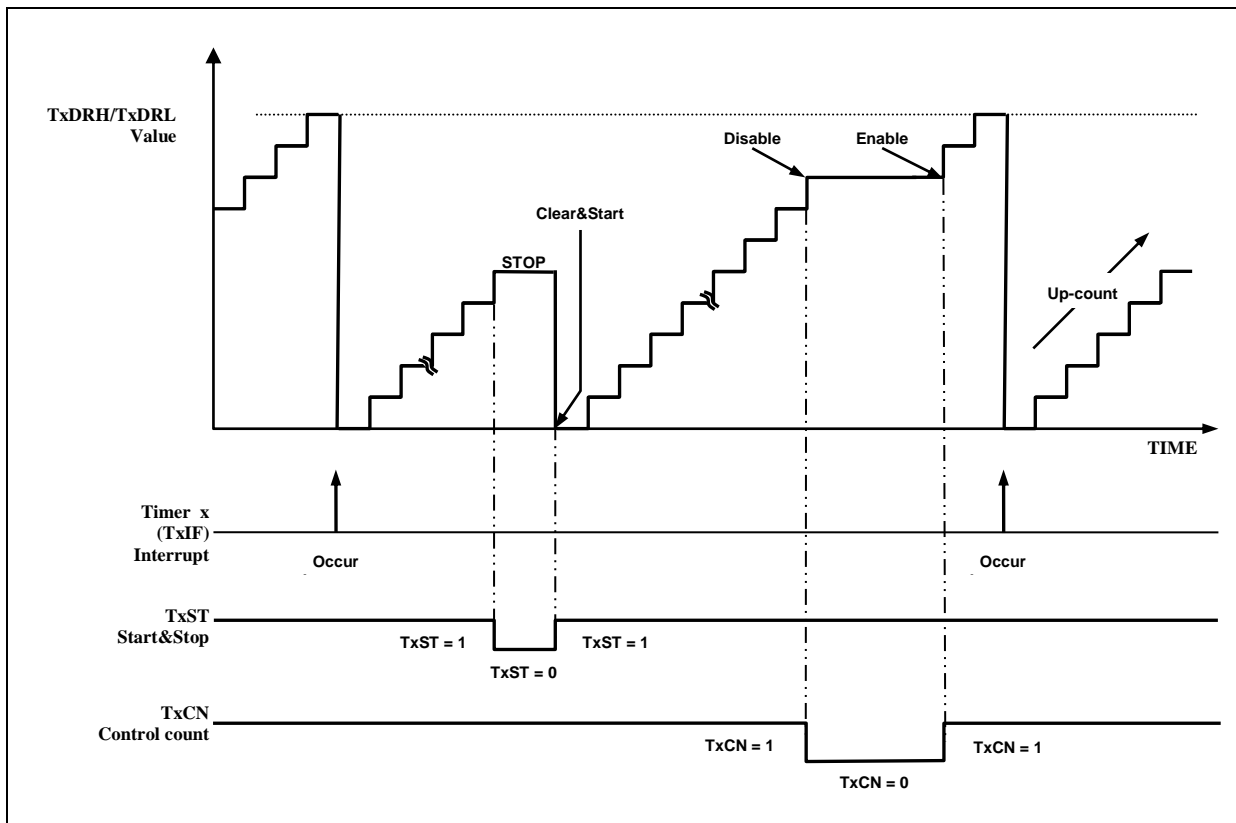

Figure 11-9 Operation Example of Timer/Event Counter Mode

11.6.1.3 16-Bit Capture Mode

The timer x capture mode is set by CAPx as '1' in TxCR register. The clock is same source as Output Compare mode. The interrupt occurs at TxH, TxL and TxDRH, TxDRL matching time. The capture result is loaded into CDRxH, CDRxL. The TxH, TxL value is automatically cleared(0000_H) by hardware and restarts counter.

This timer interrupt in capture mode is very useful when the pulse width of captured signal is wider than the maximum period of timer. As the PCIx register setting, the PCIx (Pin Chagen Interrupt) function is chosen. (PCI0 for Timer0 and Timer2 Capture Mode, PCI1 for Timer1 Capture Mode)

The CDRxH, PWMxDRH and TxH are in same address. In the capture mode, reading operation is read the CDRxH, not TxH because path is opened to the CDRxH. PWMxDRH will be changed in writing operation. The PWMxDRL, TxL, CDRxL has the same function.

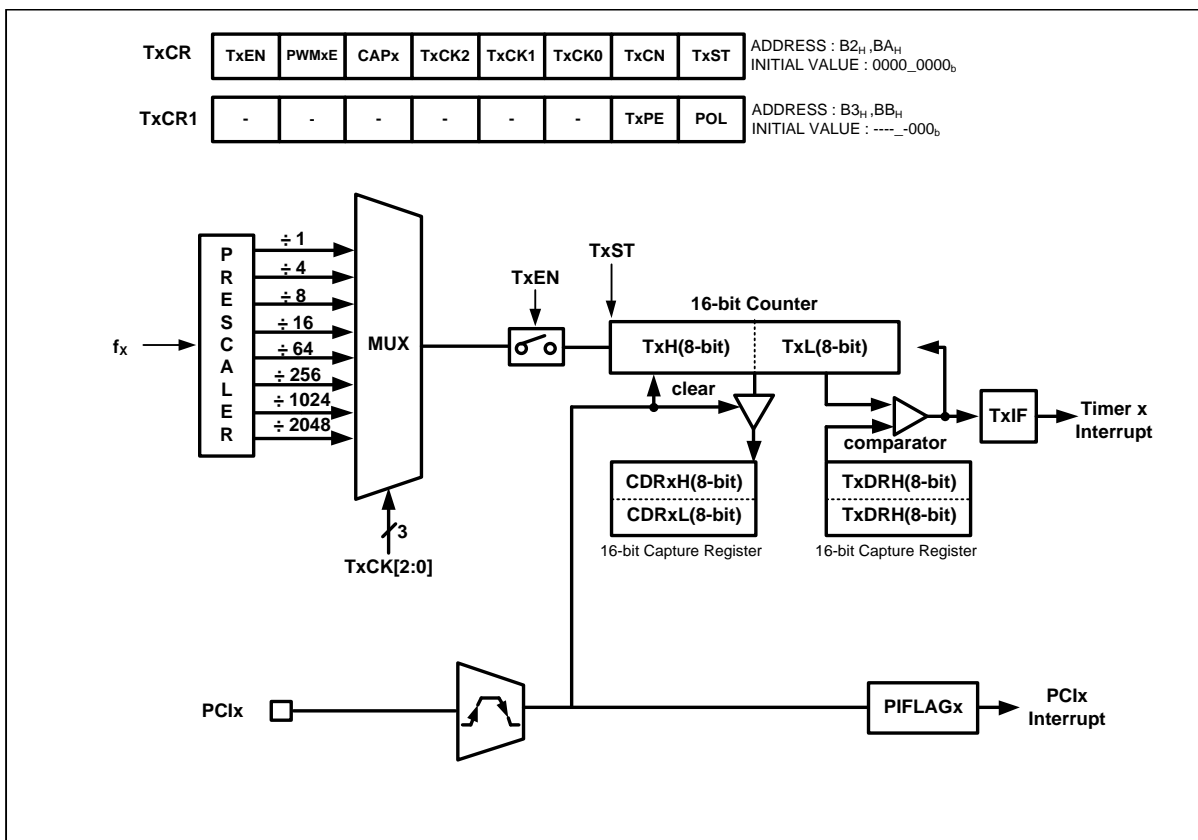

Figure 11-10 Timer x 16bit Capture Mode

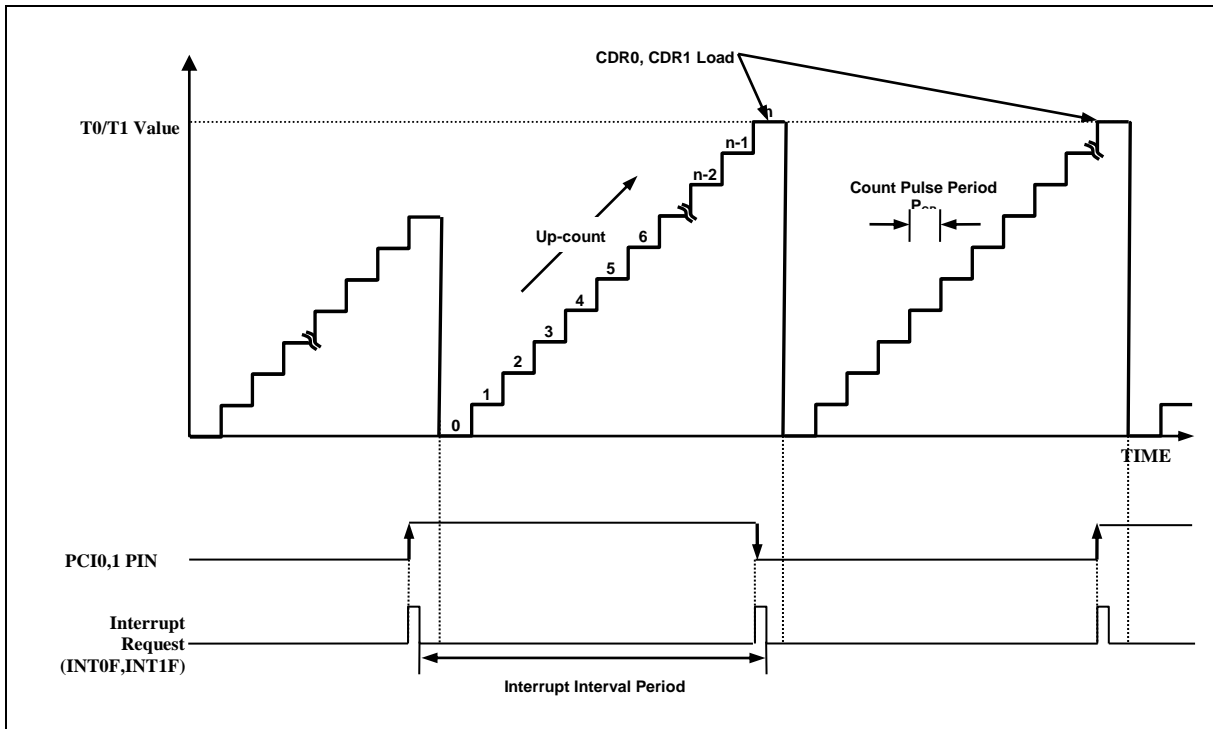

Figure 11-11 Input Capture Mode Operation of Timer 0, 1

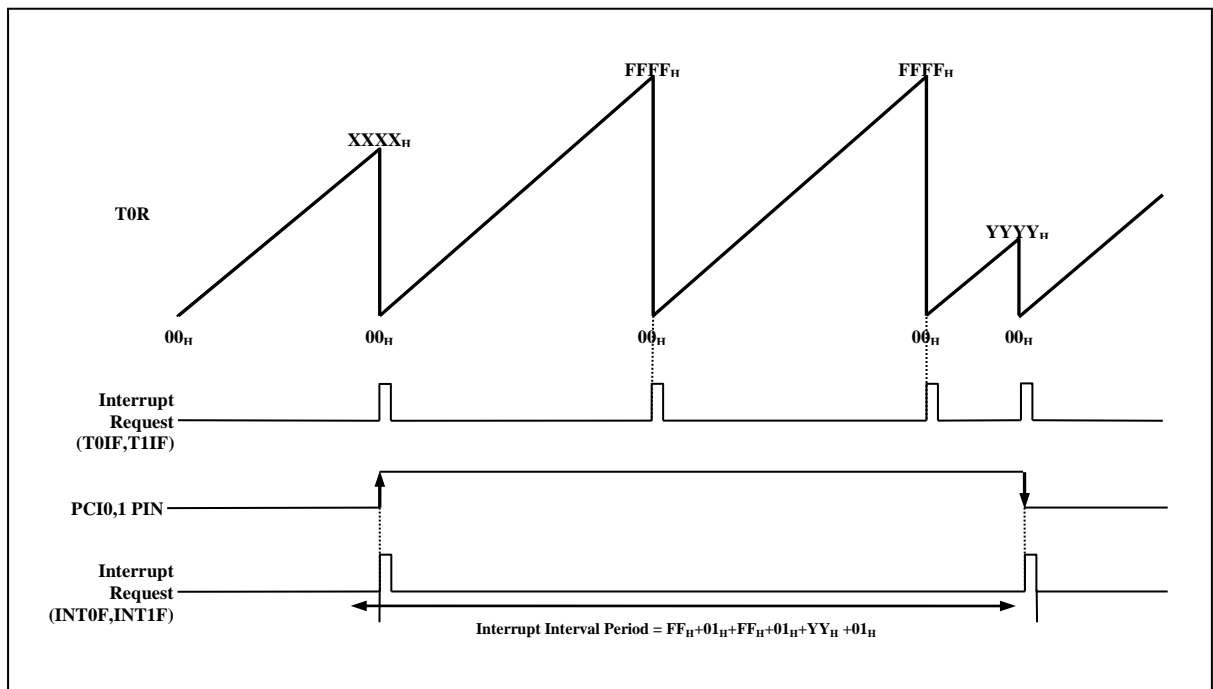

Figure 11-12 Express Timer Overflow in Capture Mode

11.6.1.4 PWM Mode

The timer x has a PWM (pulse Width Modulation) function. In PWM mode, the Tx/PWMx output pin outputs up to 16-bit resolution PWM output. This pin should be configured as a PWM output by set TX_PE to '1'. The PWM output mode is determined by the PWMxPRH, PWMxPRL, PWMxDRH and PWMxDRL. And you should configure PWMxE bit to "1" in TxCR register. PWM Period and Duty same output shown in Figure 11-15.

$$\text{PWM Period} = [\text{PWMxPRH}, \text{PWMxPRL}] \times \text{Timer x Clock Period}$$

$$\text{PWM Duty} = [\text{PWMxDRH}, \text{PWMxDRL}] \times \text{Timer x Clock Period}$$

Table 11-7 PWM Frequency vs. Resolution at 16 MHz

Resolution	Frequency		
	TxCK[2:0]=000 (62.5ns)	TxCK[2:0]=001(250ns)	TxCK[2:0]=010(500ns)
16-bit	244.141Hz	61.035Hz	30.518Hz
15-bit	488.28Hz	122.070Hz	60.035Hz
10-bit	15.625KHz	3.906KHz	1.953KHz
9-bit	31.250KHz	7.813KHz	3.906KHz
8-bit	62.500KHz	15.625KHz	7.813KHz

The POL bit of TxCR register decides the polarity of duty cycle.

The PWM function is not supported in these cases : When the duty value is "00H" or set same to the period value.

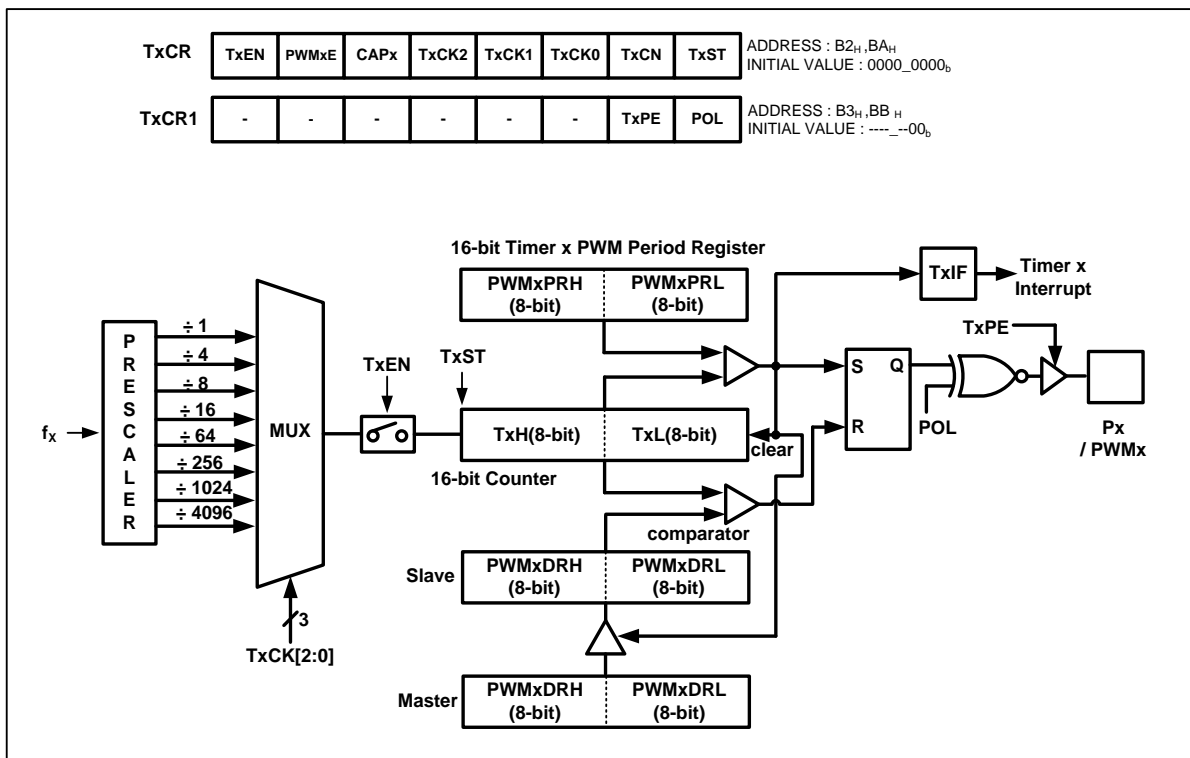

Figure 11-13 PWM Mode

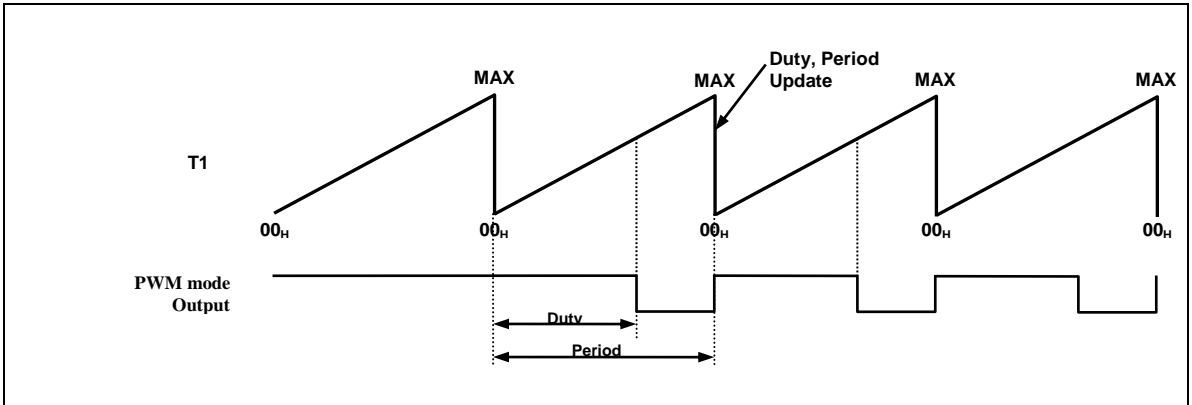

Figure 11-14 Example of PWM Output Waveform

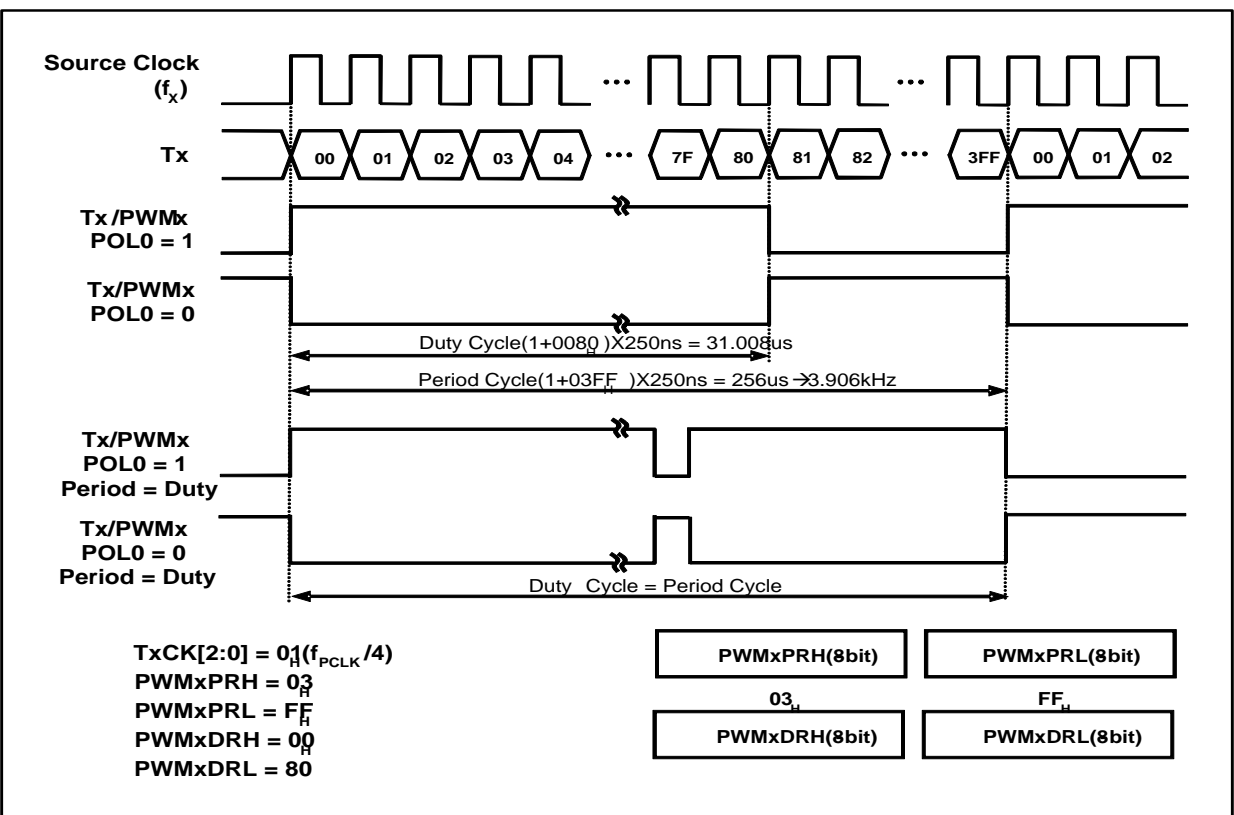

Figure 11-15 Example of PWM (16MHz)

11.6.1.5 Register Map

Table 11-8 Register Map

Name	Address	Dir	Default	Description
T0CR	B2 _H	R/W	00 _H	Timer 0 Mode Control Register
T0CR1	B3 _H	R/W	00 _H	Timer 0 Mode Control Register 1
T0L	B4 _H	R	00 _H	Timer 0 Low Register
PWM0DRL	B4 _H	R/W	00 _H	PWM 0 Duty Register Low
CDR0L	B4 _H	R	00 _H	Timer 0 Capture Data Register Low
T0H	B5 _H	R	00 _H	Timer 0 Register High
PWM0DRH	B5 _H	R/W	00 _H	PWM 0 Duty Register High
CDR0H	B5 _H	R	00 _H	Timer 0 Capture Data Register High
T0DRL	B6 _H	W	FF _H	Timer 0 Data Register Low
PWM0PRL	B6 _H	W	FF _H	PWM 0 Period Register Low
T0DRH	B7 _H	W	FF _H	Timer 0 Data Register High
PWM0PRH	B7 _H	W	FF _H	PWM 0 Period Register High
T1CR	BA _H	R/W	00 _H	Timer 1 Mode Control Register
T1CR1	BB _H	R/W	00 _H	Timer 1 Mode Control Register 1
T1L	BC _H	R	00 _H	Timer 1 Register Low
PWM1DRL	BC _H	R/W	00 _H	PWM 1 Duty Register Low
CDR1L	BC _H	R	00 _H	Timer 1 Capture Data Register Low
T1H	BD _H	R	00 _H	Timer 1 Register High
PWM1DRH	BD _H	R/W	00 _H	PWM 1 Duty Register High
CDR1H	BD _H	R	00 _H	Timer 1 Capture Data Register High
T1DRL	BE _H	W	FF _H	Timer 1 Data Register Low
PWM1PRL	BE _H	W	FF _H	PWM 1 Period Register Low
T1DRH	BF _H	W	FF _H	Timer 1 Data Register High
PWM1PRH	BF _H	W	FF _H	PWM 1 Period Register High
T2CR	C2 _H	R/W	00 _H	Timer 2 Mode Control Register
T2CR1	C3 _H	R/W	00 _H	Timer 2 Mode Control Register 1
T2L	C4 _H	R	00 _H	Timer 2 Low Register
PWM2DRL	C4 _H	R/W	00 _H	PWM 2 Duty Register Low
CDR2L	C4 _H	R	00 _H	Timer 2 Capture Data Register Low
T2H	C5 _H	R	00 _H	Timer 2 Register High
PWM2DRH	C5 _H	R/W	00 _H	PWM 2 Duty Register High
CDR2H	C5 _H	R	00 _H	Timer 2 Capture Data Register High
T2DRL	C6 _H	W	FF _H	Timer 2 Data Register Low
PWM2PRL	C6 _H	W	FF _H	PWM 2 Period Register Low
T2DRH	C7 _H	W	FF _H	Timer 2 Data Register High
PWM2PRH	C7 _H	W	FF _H	PWM 2 Period Register High

11.6.1.6 Timer/Counter x Register Description

The Timer 0~x Register consists of Timer 0~x Mode Control Register (T0CR), (T1CR), Timer 0~x Mode Control Register 1 (T0CR1), (T1CR1), Timer 0~x Low Register (T0L), (T1L), Timer 0~x Data Register Low (T0DRL), (T1DRL), Timer 0~x High Register (T0H), (T1H) Timer 0~x Data Register High (T0DRH), (T1DRH), Timer 0~x Capture Data Low Register (CDR0L), (CDR1L), Timer 0~x Capture Data High Register (CDR0H), (CDR1H), PWM0~x Low Duty Register (PWM0DRL), (PWM1DRL), PWM0~x High Duty Register (PWM0DRH), (PWM1DRH), PWM0~x Low Period Register (PWM0PRL), (PWM1PRL), PWM0~x High Period Register (PWM0PRH), (PWM1PRH).

11.6.1.7 Register Description for Timer/Counter x

T0CR, T1CR, T2CR (Timer 0~2 Mode Control Register): B2H, BAH, C2H

7	6	5	4	3	2	1	0
TxEN	PWMxE	CAPx	TxCK2	TxCK1	TxCK0	TxCN	TxST
R/W	R/W	R/W	R/W	R/W	R/W	R/W	R/W

Initial value : 00H

TxEN	Control Timer X			
	0	0		
	1	Timer X enable		
PWMxE	Control PWM X enable			
	0	PWM X disable		
	1	PWM X enable		
CAPx	Control Timer X capture mode.			
	0	Timer mode		
	1	Capture mode		
TxCK[2:0]	Select clock source of Timer X. Fx is the frequency of main system			
	TxCK2	TxCK1	TxCK0	description
	0	0	0	f _x
	0	0	1	f _x /4
	0	1	0	f _x /8
	0	1	1	f _x /16
	1	0	0	f _x /64
	1	0	1	f _x /256
	1	1	0	f _x /1024
	1	1	1	f _x /2048
TxCN	Control Timer X Count pause/continue.			
	0	Temporary count stop		
	1	Continue count		
TxST	Control Timer x start/stop			
	0	Counter stop		
	1	Clear counter and start		

Note) set TxST bit after write to Tx, PWMx, CDRx registers.

T0CR1, T1CR1, T2CR1 (Timer 0~2 Mode Control Register 1) : B3H, , BBH, C3H

7	6	5	4	3	2	1	0
-	-	-	-	-	-	Tx_PE	POL
-	-	-	-	-	-	RW	RW

Initial value : 00_H

T0_PE Control Timer X Output port
 0 Timer X Output disable
 1 Timer X Output enable

POL Configure PWM polarity
 0 Negative (Duty Match: Set)
 1 Positive (Duty Match: Clear)

T0L, T1L, T2L (Timer 0~2 Register Low, Read Case) : B4H, BCH, C4H

7	6	5	4	3	2	1	0
TxL7	TxL6	TxL5	TxL4	TxL3	TxL2	TxL1	TxL0
R	R	R	R	R	R	R	R

Initial value : 00_H

TxL[7:0] TxL Counter Period Low data.

CDR0L, CDR1L, CDR2L (Capture 0~2 Data Register Low, Read Case) : B4H, BCH, C4H

7	6	5	4	3	2	1	0
CDRxL07	CDRxL06	CDRxL05	CDRxL04	CDRxL03	CDRxL02	CDRxL01	CDRxL00
R	R	R	R	R	R	R	R

Initial value : 00_H

CDRxL[7:0] Tx Capture Low data.

PWM0DRL, PWM1DRL (PWM 0~2 Duty Register Low, Write Case) : B4H, BCH, C4H

7	6	5	4	3	2	1	0
PWMxLD7	PWMxLD6	PWMxLD5	PWMxLD4	PWMxLD3	PWMxLD2	PWMxLD1	PWMxLD0
W	W	W	W	W	W	W	W

Initial value : 00_H

PWMxLD[7:0] Tx PWM Duty Low data
 Note) Writing is effective only when PWMxE = 1 and TOST = 0

T0H, T1H, T2H (Timer 0~2 Register High, Read Case) : B5H, BDH, C5H

7	6	5	4	3	2	1	0
TxH7	TxH6	TxH5	TxH4	TxH3	TxH2	TxH1	TxH0
R	R	R	R	R	R	R	R

Initial value : 00_H

TxH[7:0] TxH Counter Period High data.

CDR0H, CDR1H, CDR2H (Capture 0~2 Data High Register, Read Case) : B5H, BDH, C5H

7	6	5	4	3	2	1	0
CDRxH07	CDRxH06	CDRxH05	CDRxH04	CDRxH03	CDRxH02	CDRxH01	CDRxH00
R	R	R	R	R	R	R	R

Initial value : 00_H

CDRxH[7:0] Tx Capture High data

PWM0DRH, PWM1DRH, PWM2DRH (PWM 0~2 Duty Register High, Write Case) : B5H, BDH, C5H

7	6	5	4	3	2	1	0
PWMxHD7	PWMxHD6	PWMxHD5	PWMxHD4	PWMxHD3	PWMxHD2	PWMxHD1	PWMxHD0
W	W	W	W	W	W	W	W

Initial value : 00_H

PWMxHD[7:0] Tx PWM Duty High data

Note) Writing is effective only when PWMxE = 1 and T0ST = 0

T0DRL, T1DRL, T2DRL (Timer 0~2 Data Register Low, Write Case) : B6H, BEH, C6H

7	6	5	4	3	2	1	0
TxLD7	TxLD6	TxLD5	TxLD4	TxLD3	TxLD2	TxLD1	TxLD0
W	W	W	W	W	W	W	W

Initial value : FF_H

TxLD[7:0] TxL Compare Low data

Note) Be sure to clear PWMxE before loading this register.

PWM0PRL, PWM1PRL, PWM2PRL (PWM 0~2 Period Register Low, Write Case) : B6H, BEH, C6H

7	6	5	4	3	2	1	0
PWM0LP7	PWM0LP6	PWM0LP5	PWM0LP4	PWM0LP3	PWM0LP2	PWM0LP1	PWM0LP0
W	W	W	W	W	W	W	W

Initial value : FF_H

PWM0LP[7:0] T0 PWM Duty Low data

Note) Writing is effective only when PWM0E = 1 and T0ST = 0

T0DRH, T1DRH, T2DRH (Timer 0~2 Data Register High, Write Case) : B7H, BFH, C7H

7	6	5	4	3	2	1	0
TxHD7	TxHD6	TxHD5	TxHD4	TxHD3	TxHD2	TxHD1	TxHD0
W	W	W	W	W	W	W	W

Initial value : FF_H

TxHD[7:0] TxH Compare High data

Note) Be sure to clear PWMxE before loading this register.

PWM0PRH, PWM1PRH, PWM2PRH (PWM 0~2 Period Register High, Write Case) : B7H, BFH, C7H

7	6	5	4	3	2	1	0
PWMxHP7	PWMxHP6	PWMxHP5	PWMxHP4	PWMxHP3	PWMxHP2	PWMxHP1	PWMxHP0
R/W	W	W	W	W	W	W	W

Initial value : FF_H**PWMxHP[7:0]** Tx PWM Duty High data

Note) Writing is effective only when PWMxE = 1 and TOST = 0

11.7 USART

11.7.1 Overview

The Universal Synchronous and Asynchronous serial Receiver and Transmitter (USART) is a highly flexible serial communication device. The main features are listed below.

- Full Duplex Operation (Independent Serial Receive and Transmit Registers)
- Asynchronous or Synchronous Operation
- Master or Slave Clocked Synchronous and SPI Operation
- Supports all four SPI Modes of Operation (Mode 0, 1, 2, 3)
- LSB First or MSB First Data Transfer @SPI mode
- High Resolution Baud Rate Generator
- Supports Serial Frames with 5,6,7,8, or 9 Data Bits and 1 or 2 Stop Bits
- Odd or Even Parity Generation and Parity Check Supported by Hardware
- Data OverRun Detection
- Framing Error Detection
- Digital Low Pass Filter
- Three Separate Interrupts on TX Complete, TX Data Register Empty and RX Complete
- Double Speed Asynchronous Communication Mode

USART has three main parts of Clock Generator, Transmitter and Receiver. The Clock Generation logic consists of synchronization logic for external clock input used by synchronous or SPI slave operation, and the baud rate generator for asynchronous or master (synchronous or SPI) operation. The Transmitter consists of a single write buffer, a serial shift register, parity generator and control logic for handling different serial frame formats. The write buffer allows a continuous transfer of data without any delay between frames. The receiver is the most complex part of the USART module due to its clock and data recovery units. The recovery unit is used for asynchronous data reception. In addition to the recovery unit, the Receiver includes a parity checker, a shift register, a two level receive FIFO(UDATA) and control logic. The Receiver supports the same frame formats as the Transmitter and can detect Frame Error, Data OverRun and Parity Errors.

11.7.2 Block Diagram

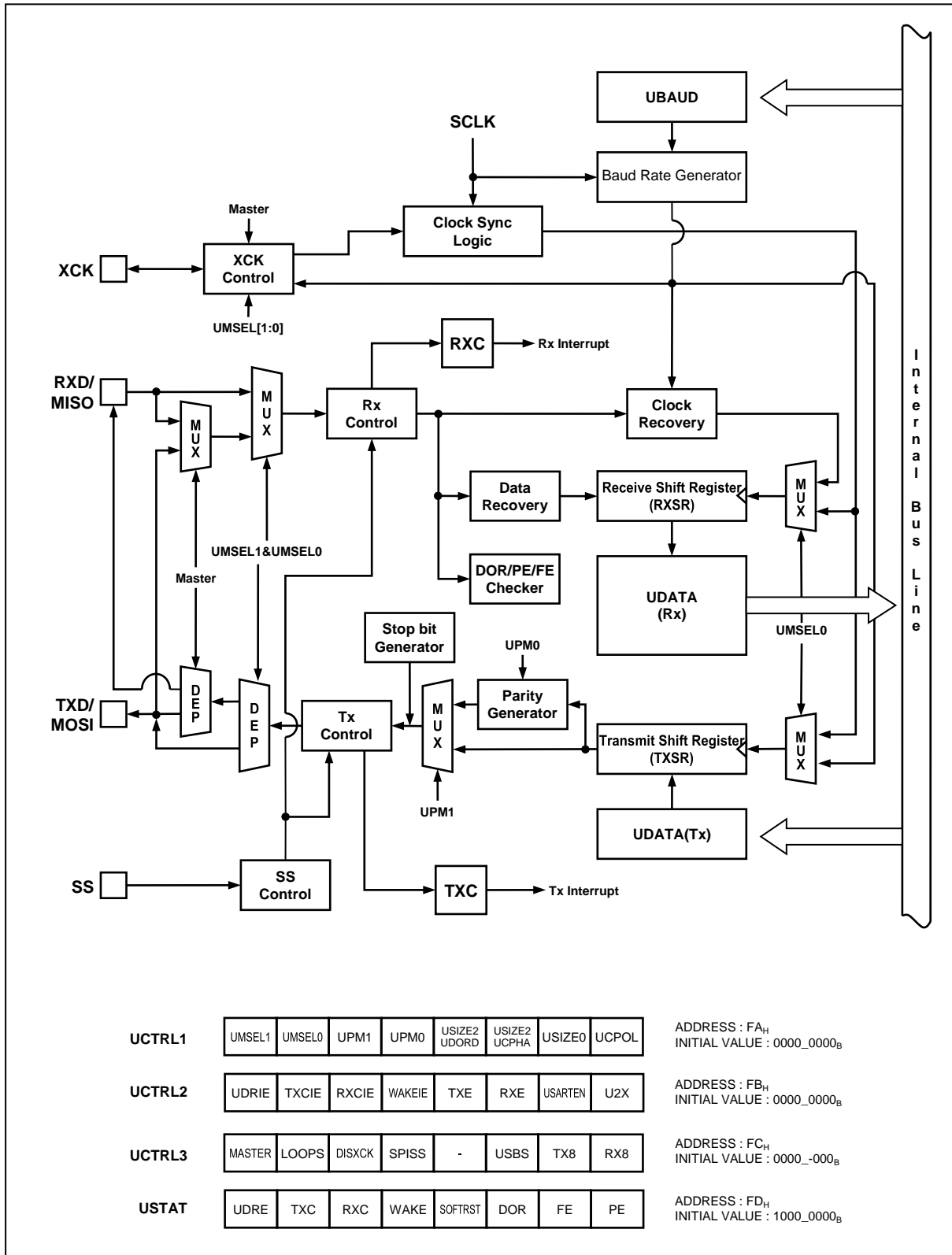

Figure 11-16 USART Block Diagram

11.7.3 Clock Generation

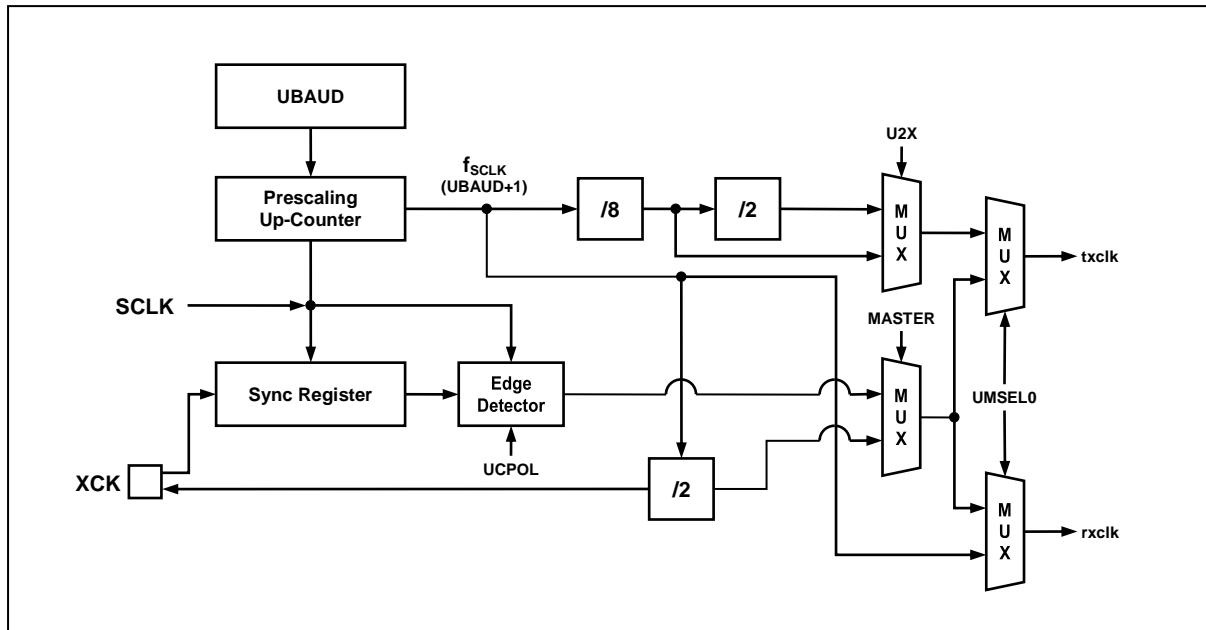

Figure 11-17 Clock Generation Block Diagram

The Clock generation logic generates the base clock for the Transmitter and Receiver. The USART supports four modes of clock operation and those are Normal Asynchronous, Double Speed Asynchronous, Master Synchronous and Slave Synchronous. The clock generation scheme for Master SPI and Slave SPI mode is the same as Master Synchronous and Slave Synchronous operation mode. The UMSELn bit in UCTRL1 register selects between asynchronous and synchronous operation. Asynchronous Double Speed mode is controlled by the U2X bit in the UCTRL2 register. The MASTER bit in UCTRL2 register controls whether the clock source is internal (Master mode, output port) or external (Slave mode, input port). The XCK pin is only active when the USART operates in Synchronous or SPI mode.

Table below contains equations for calculating the baud rate (in bps).

Table 11-9 Equations for Calculating Baud Rate Register Setting

Operating Mode	Equation for Calculating Baud Rate
Asynchronous Normal Mode (U2X=0)	$\text{Baud Rate} = \frac{f_{\text{SCLK}}}{16(\text{UBAUD}_x + 1)}$
Asynchronous Double Speed Mode (U2X=1)	$\text{Baud Rate} = \frac{f_{\text{SCLK}}}{8(\text{UBAUD}_x + 1)}$
Synchronous or SPI Master Mode	$\text{Baud Rate} = \frac{f_{\text{SCLK}}}{2(\text{UBAUD}_x + 1)}$

11.7.4 External Clock (XCK)

External clocking is used by the synchronous or SPI slave modes of operation.

External clock input from the XCK pin is sampled by a synchronization logic to remove meta-stability. The output from the synchronization logic must then pass through an edge detector before it can be used by the Transmitter and Receiver. This process introduces a two CPU clock period delay and therefore the maximum frequency of the external XCK pin is limited by the following equation.

$$f_{XCK} = \frac{f_{SCLK}}{4}$$

where f_{XCK} is the frequency of XCK and f_{SCLK} is the frequency of main system clock (SCLK).

11.7.5 Synchronous Mode Operation

When synchronous or spi mode is used, the XCK pin will be used as either clock input (slave) or clock output (master). The dependency between the clock edges and data sampling or data change is the same. The basic principle is that data input on RXD (MISO in spi mode) pin is sampled at the opposite XCK clock edge of the edge in the data output on TXD (MOSI in spi mode) pin is changed.

The UC POL bit in UCTRL1 register selects which XCK clock edge is used for data sampling and which is used for data change. As shown in the figure below, when UC POL is zero the data will be changed at rising XCK edge and sampled at falling XCK edge.

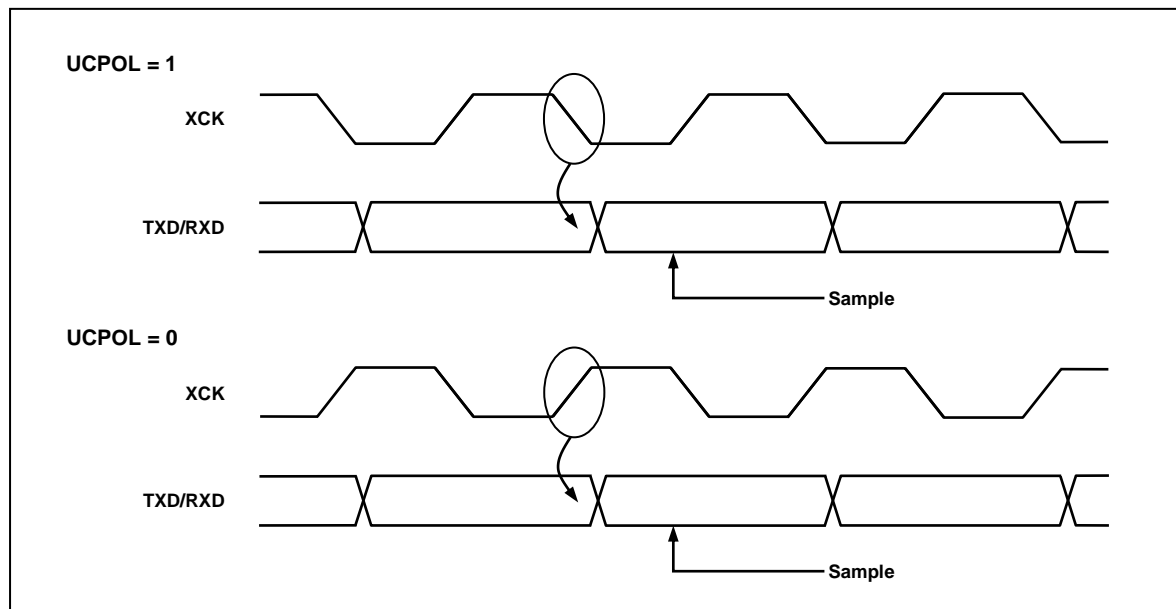

Figure 11-18 Synchronous Mode XCKn Timing

11.7.6 Data Format

A serial frame is defined to be one character of data bits with synchronization bits (start and stop bits), and optionally a parity bit for error checking.

The USART supports all 30 combinations of the following as valid frame formats.

- 1 start bit
- 5, 6, 7, 8 or 9 data bits
- no, even or odd parity bit
- 1 or 2 stop bits

A frame starts with the start bit followed by the least significant data bit (LSB). Then the next data bits, up to a total of nine, are succeeding, ending with the most significant bit (MSB). If enabled the parity bit is inserted after the data bits, before the stop bits. A high to low transition on data pin is considered as start bit. When a complete frame is transmitted, it can be directly followed by a new frame, or the communication line can be set to an idle state. The idle means high state of data pin. The next figure shows the possible combinations of the frame formats. Bits inside brackets are optional.

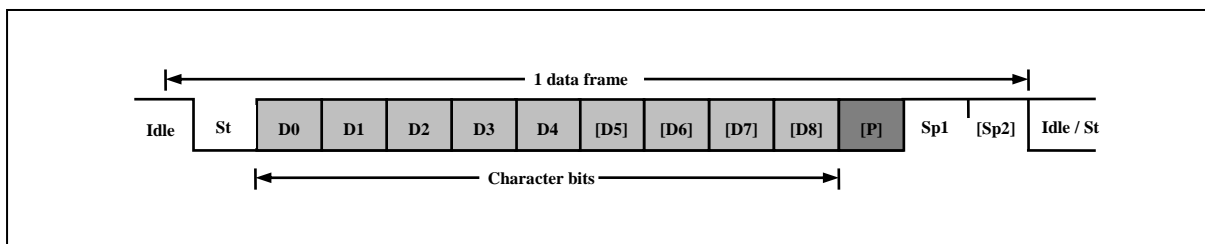

Figure 11-19 Frame Format

1 data frame consists of the following bits

- Idle No communication on communication line (TxD/RxD)
- St Start bit (Low)
- Dn Data bits (0~8)
- Parity bit ----- Even parity, Odd parity, No parity
- Stop bit(s) ----- 1 bit or 2 bits

The frame format used by the USART is set by the USIZE[2:0], UPM[1:0] and USBS bits in UCTRL1 register. The Transmitter and Receiver use the same setting.

11.7.7 Parity Bit

The parity bit is calculated by doing an exclusive-or of all the data bits. If odd parity is used, the result of the exclusive-or is inverted. The parity bit is located between the MSB and first stop bit of a serial frame.

$$P_{\text{even}} = D_{n-1} \wedge \dots \wedge D_3 \wedge D_2 \wedge D_1 \wedge D_0 \wedge 0$$

$$P_{\text{odd}} = D_{n-1} \wedge \dots \wedge D_3 \wedge D_2 \wedge D_1 \wedge D_0 \wedge 1$$

P_{even} : Parity bit using even parity

P_{odd} : Parity bit using odd parity

D_n : Data bit n of the character

11.7.8 USART Transmitter

The USART Transmitter is enabled by setting the TXE bit in UCTRL2 register. When the Transmitter is enabled, the normal port operation of the TXD pin is overridden by the serial output pin of USART. The baud-rate, operation mode and frame format must be setup once before doing any transmissions. If synchronous or spi operation is used, the clock on the XCK pin will be overridden and used as transmission clock. If USART operates in spi mode, SS pin is used as SS input pin in slave mode or can be configured as SS output pin in master mode. This can be done by setting SPISS bit in UCTRL3 register.

11.7.8.1 Sending Tx data

A data transmission is initiated by loading the transmit buffer (UDATA register I/O location) with the data to be transmitted. The data written in transmit buffer is moved to the shift register when the shift register is ready to send a new frame. The shift register is loaded with the new data if it is in idle state or immediately after the last stop bit of the previous frame is transmitted. When the shift register is loaded with new data, it will transfer one complete frame at the settings of control registers. If the 9-bit characters are used in asynchronous or synchronous operation mode (USIZE[2:0]=7), the ninth bit must be written to the TX8 bit in UCTRL3 register before loading transmit buffer (UDATA register).

11.7.8.2 Transmitter flag and interrupt

The USART Transmitter has 2 flags which indicate its state. One is USART Data Register Empty (UDRE) and the other is Transmit Complete (TXC). Both flags can be interrupt sources.

UDRE flag indicates whether the transmit buffer is ready to be loaded with new data. This bit is set when the transmit buffer is empty and cleared when the transmit buffer contains data to be transmitted that has not yet been moved into the shift register. And also this flag can be cleared by writing '0' to this bit position. Writing '1' to this bit position is prevented.

When the Data Register Empty Interrupt Enable (UDRIE) bit in UCTRL2 register is set and the Global Interrupt is enabled, USART Data Register Empty Interrupt is generated while UDRE flag is set.

The Transmit Complete (TXC) flag bit is set when the entire frame in the transmit shift register has been shifted out and there are no more data in the transmit buffer. The TXC flag is automatically

cleared when the Transmit Complete Interrupt service routine is executed, or it can be cleared by writing '0' to TXC bit in USTAT register.

When the Transmit Complete Interrupt Enable (TXCIE) bit in UCTRL2 register is set and the Global Interrupt is enabled, USART Transmit Complete Interrupt is generated while TXC flag is set.

11.7.8.3 Parity Generator

The Parity Generator calculates the parity bit for the sending serial frame data. When parity bit is enabled (UPM[1]=1), the transmitter control logic inserts the parity bit between the MSB and the first stop bit of the sending frame.

11.7.8.4 Disabling Transmitter

Disabling the Transmitter by clearing the TXE bit will not become effective until ongoing transmission is completed. When the Transmitter is disabled, the TXD pin is used as normal General Purpose I/O (GPIO) or primary function pin.

11.7.9 USART Receiver

The USART Receiver is enabled by setting the RXE bit in the UCTRL1 register. When the Receiver is enabled, the normal pin operation of the RXD pin is overridden by the USART as the serial input pin of the Receiver. The baud-rate, mode of operation and frame format must be set before serial reception. If synchronous or spi operation is used, the clock on the XCK pin will be used as transfer clock. If USART operates in spi mode, SS pin is used as SS input pin in slave mode or can be configured as SS output pin in master mode. This can be done by setting SPISS bit in UCTRL3 register.

11.7.9.1 Receiving Rx data

When USART is in synchronous or asynchronous operation mode, the Receiver starts data reception when it detects a valid start bit (LOW) on RXD pin. Each bit after start bit is sampled at pre-defined baud-rate (asynchronous) or sampling edge of XCK (synchronous), and shifted into the receive shift register until the first stop bit of a frame is received. Even if there's 2nd stop bit in the frame, the 2nd stop bit is ignored by the Receiver. That is, receiving the first stop bit means that a complete serial frame is present in the receiver shift register and contents of the shift register are to be moved into the receive buffer. The receive buffer is read by reading the UDATA register.

If 9-bit characters are used (USIZE[2:0] = 7) the ninth bit is stored in the RX8 bit position in the UCTRL3 register. The 9th bit must be read from the RX8 bit before reading the low 8 bits from the UDATA register. Likewise, the error flags FE, DOR, PE must be read before reading the data from UDATA register. This is because the error flags are stored in the same FIFO position of the receive buffer.

11.7.9.2 Receiver flag and interrupt

The USART Receiver has one flag that indicates the Receiver state.

The Receive Complete (RXC) flag indicates whether there are unread data present in the receive buffer. This flag is set when there are unread data in the receive buffer and cleared when the receive buffer is empty. If the Receiver is disabled (RXE=0), the receiver buffer is flushed and the RXC flag is cleared.

When the Receive Complete Interrupt Enable (RXCIE) bit in the UCTRL2 register is set and Global Interrupt is enabled, the USART Receiver Complete Interrupt is generated while RXC flag is set.

The USART Receiver has three error flags which are Frame Error (FE), Data OverRun (DOR) and Parity Error (PE). These error flags can be read from the USTAT register. As data received are stored in the 2-level receive buffer, these error flags are also stored in the same position of receive buffer. So, before reading received data from UDATA register, read the USTAT register first which contains error flags.

The Frame Error (FE) flag indicates the state of the first stop bit. The FE flag is zero when the stop bit was correctly detected as one, and the FE flag is one when the stop bit was incorrect, ie detected as zero. This flag can be used for detecting out-of-sync conditions between data frames.

The Data OverRun (DOR) flag indicates data loss due to a receive buffer full condition. A DOR occurs when the receive buffer is full, and another new data is present in the receive shift register which are to be stored into the receive buffer. After the DOR flag is set, all the incoming data are lost. To prevent data loss or clear this flag, read the receive buffer.

The Parity Error (PE) flag indicates that the frame in the receive buffer had a Parity Error when received. If Parity Check function is not enabled (UPM[1]=0), the PE bit is always read zero.

Note) The error flags related to receive operation are not used when USART is in SPI mode.

11.7.9.3 Parity Checker

If Parity Bit is enabled (UPM[1]=1), the Parity Checker calculates the parity of the data bits in incoming frame and compares the result with the parity bit from the received serial frame.

11.7.9.4 Disabling Receiver

In contrast to Transmitter, disabling the Receiver by clearing RXE bit makes the Receiver inactive immediately. When the Receiver is disabled the Receiver flushes the receive buffer and the remaining data in the buffer is all reset. The RXD pin is not overridden the function of USART, so RXD pin becomes normal GPIO or primary function pin.

11.7.9.5 Asynchronous Data Reception

To receive asynchronous data frame, the USART includes a clock and data recovery unit. The Clock Recovery logic is used for synchronizing the internally generated baud-rate clock to the incoming asynchronous serial frame on the RXD pin.

The Data recovery logic samples and low pass filters the incoming bits, and this removes the noise of RXD pin.

The next figure illustrates the sampling process of the start bit of an incoming frame. The sampling rate is 16 times the baud-rate for normal mode, and 8 times the baud rate for Double Speed mode (U2X=1). The horizontal arrows show the synchronization variation due to the asynchronous sampling process. Note that larger time variation is shown when using the Double Speed mode.

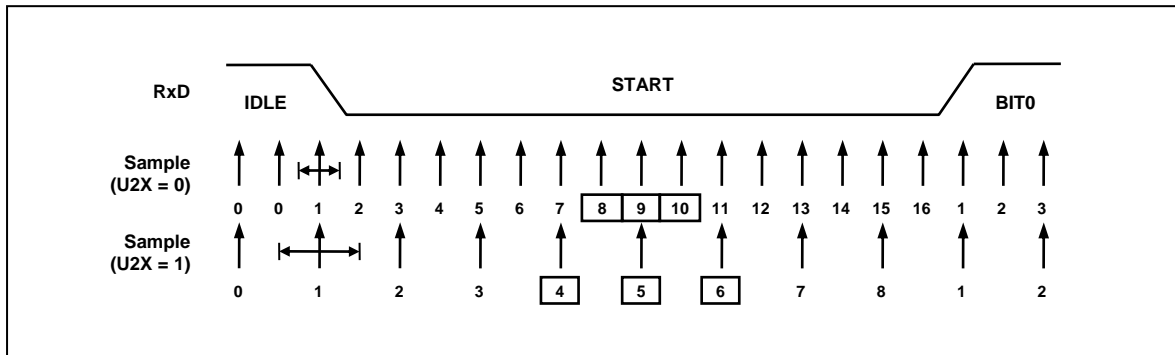

Figure 11-20 Start Bit Sampling

When the Receiver is enabled (RXE=1), the clock recovery logic tries to find a high to low transition on the RXD line, the start bit condition. After detecting high to low transition on RXD line, the clock recovery logic uses samples 8,9, and 10 for Normal mode, and samples 4, 5, and 6 for Double Speed mode to decide if a valid start bit is received. If more than 2 samples have logical low level, it is considered that a valid start bit is detected and the internally generated clock is synchronized to the incoming data frame. And the data recovery can begin. The synchronization process is repeated for each start bit.

As described above, when the Receiver clock is synchronized to the start bit, the data recovery can begin. Data recovery process is almost similar to the clock recovery process. The data recovery logic samples 16 times for each incoming bits for Normal mode and 8 times for Double Speed mode. And uses sample 8, 9, and 10 to decide data value for Normal mode, samples 4, 5, and 6 for Double Speed mode. If more than 2 samples have low levels, the received bit is considered to a logic 0 and more than 2 samples have high levels, the received bit is considered to a logic 1. The data recovery process is then repeated until a complete frame is received including the first stop bit. The decided bit value is stored in the receive shift register in order. Note that the Receiver only uses the first stop bit of a frame. Internally, after receiving the first stop bit, the Receiver is in idle state and waiting to find start bit.

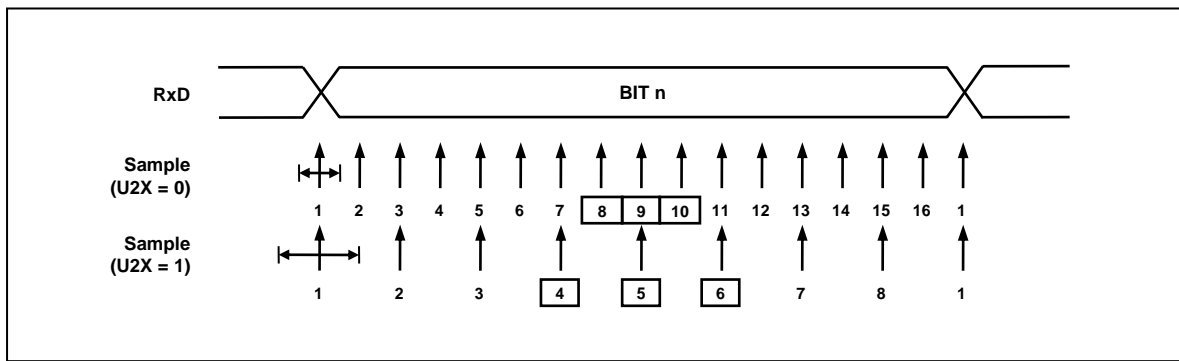

Figure 11-21 Sampling of Data and Parity Bit

The process for detecting stop bit is like clock and data recovery process. That is, if 2 or more samples of 3 center values have high level, correct stop bit is detected, else a Frame Error flag is set. After deciding first stop bit whether a valid stop bit is received or not, the Receiver goes idle state and monitors the RXD line to check a valid high to low transition is detected (start bit detection).

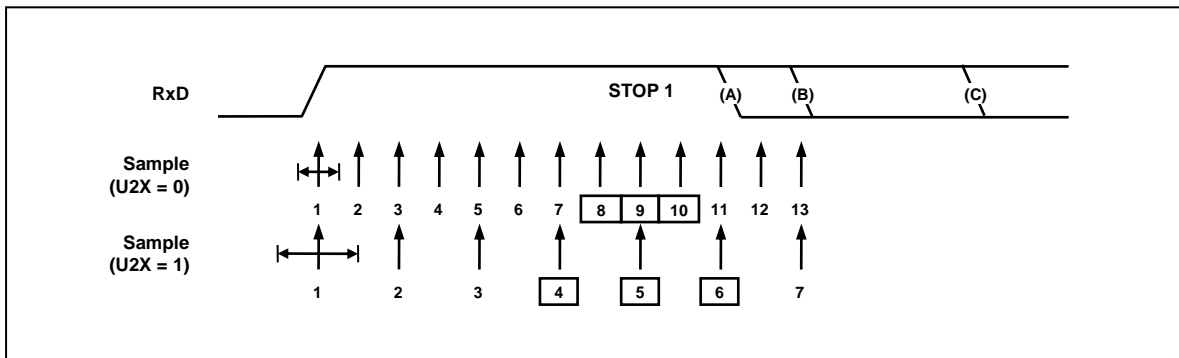

Figure 11-22 Stop Bit Sampling and Next Start Bit Sampling

11.7.10 SPI Mode

The USART can be set to operate in industrial standard SPI compliant mode. The SPI mode has the following features.

- Full duplex, three-wire synchronous data transfer
- Master or Slave operation
- Supports all four SPI modes of operation (mode0, 1, 2, and 3)
- Selectable LSB first or MSB first data transfer
- Double buffered transmit and receive
- Programmable transmit bit rate

When SPI mode is enabled (UMSEL[1:0]=3), the Slave Select (SS) pin becomes active low input in slave mode operation, or can be output in master mode operation if SPISS bit is set.

Note that during SPI mode of operation, the pin RXD is renamed as MISO and TXD is renamed as MOSI for compatibility to other SPI devices.

11.7.10.1 SPI Clock formats and timing

To accommodate a wide variety of synchronous serial peripherals from different manufacturers, the USART has a clock polarity bit (UCPOL) and a clock phase control bit (UCPHA) to select one of four clock formats for data transfers. UCPOL selectively insert an inverter in series with the clock. UCPHA chooses between two different clock phase relationships between the clock and data. Note that UCPHA and UCPOL bits in UCTRL1 register have different meanings according to the UMSEL[1:0] bits which decides the operating mode of USART.

Table below shows four combinations of UCPOL and UCPHA for SPI mode 0, 1, 2, and 3.

Table 11-10 CPOL Funtionality

SPI Mode	UCPOL	UCPHA	Leading Edge	Trailing Edge
0	0	0	Sample (Rising)	Setup (Falling)
1	0	1	Setup (Rising)	Sample (Falling)
2	1	0	Sample (Falling)	Setup (Rising)
3	1	1	Setup (Falling)	Sample (Rising)

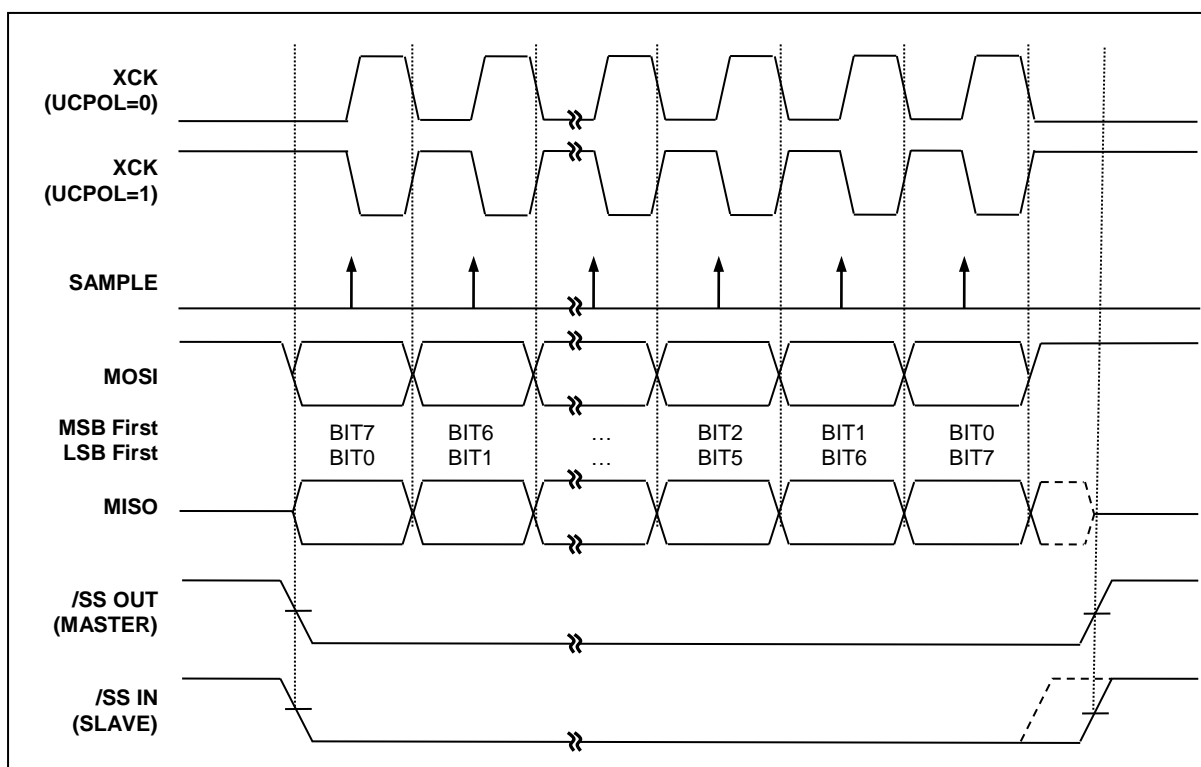

Figure 11-23 SPI Clock Formats when UCPHA=0

When UCPHA=0, the slave begins to drive its MISO output with the first data bit value when SS goes to active low. The first XCK edge causes both the master and the slave to sample the data bit value on their MISO and MOSI inputs, respectively. At the second XCK edge, the USART shifts the second data bit value out to the MOSI and MISO outputs of the master and slave, respectively. Unlike the case of UCPHA=1, when UCPHA=0, the slave's SS input must go to its inactive high level between

transfers. This is because the slave can prepare the first data bit when it detects falling edge of SS input.

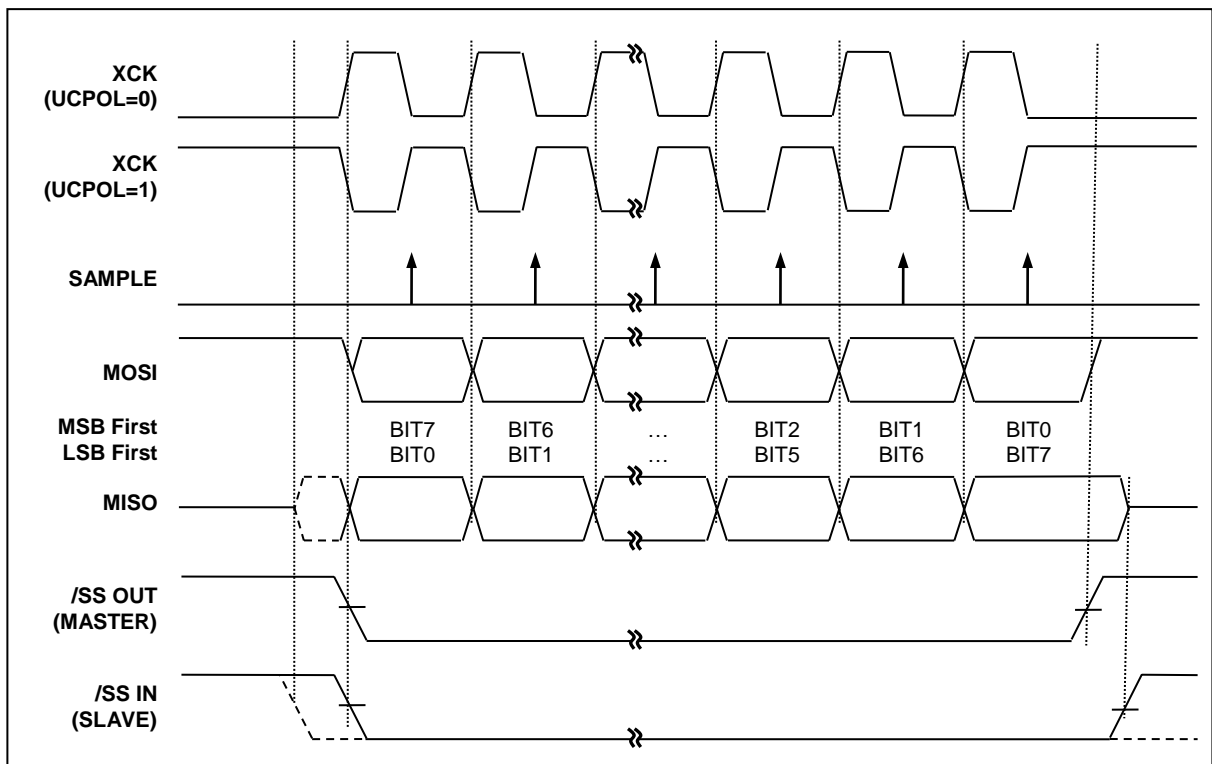

Figure 11-24 SPI Clock Formats when UCPHA=1

When UCPHA=1, the slave begins to drive its MISO output when SS goes active low, but the data is not defined until the first XCK edge. The first XCK edge shifts the first bit of data from the shifter onto the MOSI output of the master and the MISO output of the slave. The next XCK edge causes both the master and slave to sample the data bit value on their MISO and MOSI inputs, respectively. At the third XCK edge, the USART shifts the second data bit value out to the MOSI and MISO output of the master and slave respectively. When UCPHA=1, the slave's SS input is not required to go to its inactive high level between transfers.

Because the SPI logic reuses the USART resources, SPI mode of operation is similar to that of synchronous or asynchronous operation. An SPI transfer is initiated by checking for the USART Data Register Empty flag (UDRE=1) and then writing a byte of data to the UDATA Register. In master mode of operation, even if transmission is not enabled (TXE=0), writing data to the UDATA register is necessary because the clock XCK is generated from transmitter block.

11.7.11 Register Map

Table 11-11 Register Map

Name	Address	Dir	Default	Description
UCTRL1	FAH	R/W	00H	USART Control 1 Register
UCTRL2	FBH	R/W	00H	USART Control 2 Register
UCTRL3	FCH	R/W	00H	USART Control 3 Register
USTAT	FDH	R	80H	USART Status Register
UBAUD	FEH	R/W	FFH	USART Baud Rate Generation Register
UDATA	FFH	R/W	FFH	USART Data Register

11.7.12 USART Register Description

USART module consists of USART Control 1 Register (UCTRL1), USART Control 2 Register (UCTRL2), USART Control 3 Register (UCTRL3), USART Status Register (USTAT), USART Data Register (UDATA), and USART Baud Rate Generation Register (UBAUD).

11.7.13 Register Description for USART

UCTRL1 (USART Control 1 Register) : FAH

7	6	5	4	3	2	1	0
UMSEL1	UMSELO	UPM1	UPM0	USIZE2	USIZE1 UDORD	USIZE0 UCPHA	UCPOL
R/W	R/W	R/W	R/W	R/W	R/W	R/W	R/W

Initial value : 00_H

UMSEL[1:0]	Selects operation mode of USART		
UMSEL1	UMSELO	Operating Mode	
0	0	Asynchronous Mode (Normal Uart)	
0	1	Synchronous Mode (Synchronous Uart)	
1	0	Reserved	
1	1	SPI Mode	
UPM[1:0]	Selects Parity Generation and Check methods		
UPM1	UPM0	Parity mode	
0	0	No Parity	
0	1	Reserved	
1	0	Even Parity	
1	1	Odd Parity	
USIZE[2:0]	When in asynchronous or synchronous mode of operation, selects the length of data bits in frame.		
USIZE2	USIZE1	USIZE0	Data length
0	0	0	5 bit
0	0	1	6 bit
0	1	0	7 bit
0	1	1	8 bit
1	0	0	Reserved

	1	0	1	Reserved
	1	1	0	Reserved
	1	1	1	9 bit
UDORD	This bit is in the same bit position with USIZE1. In SPI mode, when set to one the MSB of the data byte is transmitted first. When set to zero the LSB of the data byte is transmitted first.			
	0	LSB First		
	1	MSB First		
UCPOL	Selects polarity of XCK in synchronous or spi mode			
	0	TXD change @Rising Edge, RXD change @Falling Edge		
	1	TXD change @ Falling Edge, RXD change @ Rising Edge		
UCPHA	This bit is in the same bit position with USIZE0. In SPI mode, along with UCPOL bit, selects one of two clock formats for different kinds of synchronous serial peripherals. Leading edge means first XCK edge and trailing edge means 2 nd or last clock edge of XCK in one XCK pulse. And Sample means detecting of incoming receive bit, Setup means preparing transmit data.			
	UCPOL	UCPHA	Leading Edge	Trailing Edge
	0	0	Sample (Rising)	Setup (Falling)
	0	1	Setup (Rising)	Sample (Falling)
	1	0	Sample (Falling)	Setup (Rising)
	1	1	Setup (Falling)	Sample (Rising)

UCTRL2 (USART Control 2 Register) : FBH

7	6	5	4	3	2	1	0
UDRIE	TXCIE	RXCIE	WAKEIE	TXE	RXE	USARTEN	U2X
RW	RW	RW	RW	RW	RW	RW	RW

Initial value : 00_H

UDRIE	Interrupt enable bit for USART Data Register Empty.
0	Interrupt from UDRE is inhibited (use polling)
1	When UDRE is set, request an interrupt
TXCIE	Interrupt enable bit for Transmit Complete.
0	Interrupt from TXC is inhibited (use polling)
1	When TXC is set, request an interrupt
RXCIE	Interrupt enable bit for Receive Complete
0	Interrupt from RXC is inhibited (use polling)
1	When RXC is set, request an interrupt
WAKEIE	Interrupt enable bit for Asynchronous Wake in STOP mode. When device is in stop mode, if RXD goes to LOW level an interrupt can be requested to wake-up system.
0	Interrupt from Wake is inhibited
1	When WAKE is set, request an interrupt
TXE	Enables the transmitter unit.
0	Transmitter is disabled
1	Transmitter is enabled
RXE	Enables the receiver unit.
0	Receiver is disabled
1	Receiver is enabled
USARTEN	Activate USART module by supplying clock.
0	USART is disabled (clock is halted)

- 1 USART is enabled
- U2X** This bit only has effect for the asynchronous operation and selects receiver sampling rate.
- 0 Normal asynchronous operation
- 1 Double Speed asynchronous operation

UCTRL3 (USART Control 3 Register) : FCH

7	6	5	4	3	2	1	0
MASTER	LOOPS	DISXCK	SPISS	-	USBS	TX8	RX8
RW	RW	RW	RW	-	RW	RW	RW

Initial value : 00H

- MASTER** Selects master or slave in SPI or Synchronous mode operation and controls the direction of XCK pin.
- 0 Slave mode operation and XCK is input pin.
- 1 Master mode operation and XCK is output pin
- LOOPS** Controls the Loop Back mode of USART, for test mode
- 0 Normal operation
- 1 Loop Back mode
- DISXCK** In Synchronous mode of operation, selects the waveform of XCK output.
- 0 XCK is free-running while USART is enabled in synchronous master mode.
- 1 XCK is active while any frame is on transferring.
- SPISS** Controls the functionality of SS pin in master SPI mode.
- 0 SS pin is normal GPIO or other primary function
- 1 SS output to other slave device
- USBS** Selects the length of stop bit in Asynchronous or Synchronous mode of operation.
- 0 1 Stop Bit
- 1 2 Stop Bit
- TX8** The ninth bit of data frame in Asynchronous or Synchronous mode of operation. Write this bit first before loading the UDATA register.
- 0 MSB (9th bit) to be transmitted is '0'
- 1 MSB (9th bit) to be transmitted is '1'
- RX8** The ninth bit of data frame in Asynchronous or Synchronous mode of operation. Read this bit first before reading the receive buffer.
- 0 MSB (9th bit) received is '0'
- 1 MSB (9th bit) received is '1'

USTAT (USART Status Register) : FDH

7	6	5	4	3	2	1	0
UDRE	TXC	RXC	WAKE	SOFTRST	DOR	FE	PE
RW	RW	RW	RW	RW	R	R	R

Initial value : 80H

- UDRE** The UDRE flag indicates if the transmit buffer (UDATA) is ready to be loaded with new data. If UDRE is '1', it means the transmit buffer is empty and can hold one or two new data. This flag can generate an UDRE interrupt. Writing '0' to this bit position will clear UDRE flag.

	0	Transmit buffer is not empty.
	1	Transmit buffer is empty.
TXC		This flag is set when the entire frame in the transmit shift register has been shifted out and there is no new data currently present in the transmit buffer. This flag is automatically cleared when the interrupt service routine of a TXC interrupt is executed. It is also cleared by writing '0' to this bit position. This flag can generate a TXC interrupt.
	0	Transmission is ongoing.
	1	Transmit buffer is empty and the data in transmit shift register are shifted out completely.
RXC		This flag is set when there are unread data in the receive buffer and cleared when all the data in the receive buffer are read. The RXC flag can be used to generate a RXC interrupt.
	0	There is no data unread in the receive buffer
	1	There are more than 1 data in the receive buffer
WAKE		This flag is set when the RX pin is detected low while the CPU is in stop mode. This flag can be used to generate a WAKE interrupt. This bit is set only when in asynchronous mode of operation. ^{NOTE}
	0	No WAKE interrupt is generated.
	1	WAKE interrupt is generated.
SOFTRST		This is an internal reset and only has effect on USART. Writing '1' to this bit initializes the internal logic of USART and is auto cleared.
	0	No operation
	1	Reset USART
DOR		This bit is set if a Data OverRun occurs. While this bit is set, the incoming data frame is ignored. This flag is valid until the receive buffer is read.
	0	No Data OverRun
	1	Data OverRun detected
FE		This bit is set if the first stop bit of next character in the receive buffer is detected as '0'. This bit is valid until the receive buffer is read.
	0	No Frame Error
	1	Frame Error detected
PE		This bit is set if the next character in the receive buffer has a Parity Error when received while Parity Checking is enabled. This bit is valid until the receive buffer is read.
	0	No Parity Error
	1	Parity Error detected

^{NOTE} When the WAKE function of USART is used as a release source from STOP mode, it is required to clear this bit in the RX interrupt service routine. Else the device will not wake-up from STOP mode again by the change of RX pin.

UBAUD (USART Baud-Rate Generation Register) : FEH

7	6	5	4	3	2	1	0
UBAUD7	UBAUD6	UBAUD5	UBAUD4	UBAUD3	UBAUD2	UBAUD1	UBAUD0
R/W	R/W	R/W	R/W	R/W	R/W	R/W	R/W

Initial value : FF_H

UBAUD [7:0] The value in this register is used to generate internal baud rate in asynchronous mode or to generate XCK clock in synchronous or spi mode. To prevent malfunction, do not write '0' in asynchronous mode, and do not write '0' or '1' in synchronous or spi mode.

UDATA (USART Data Register) : FFH

7	6	5	4	3	2	1	0
UDATA7	UDATA6	UDATA5	UDATA4	UDATA3	UDATA2	UDATA1	UDATA0
R/W	R/W	R/W	R/W	R/W	R/W	R/W	R/W

Initial value : FF_H

UDATA [7:0] The USART Transmit Buffer and Receive Buffer share the same I/O address with this DATA register. The Transmit Data Buffer is the destination for data written to the UDATA register. Reading the UDATA register returns the contents of the Receive Buffer.
Write this register only when the UDRE flag is set. In spi or synchronous master mode, write this register even if TX is not enabled to generate clock, XCK.

11.7.14 Baud Rate Setting (example)

Table 11-12 Examples of UBAUD Settings for Commonly Used Oscillator Frequencies

(a) fOSC = Multiples of 1MHz

Baud Rate	fOSC =1.00MHz				fOSC =2.00MHz				fOSC =4.00MHz			
	U2X=0		U2X=1		U2X=0		U2X=1		U2X=0		U2X=1	
	UBAUD	ERROR	UBAUD	ERROR	UBAUD	ERROR	UBAUD	ERROR	UBAUD	ERROR	UBAUD	ERROR
2400	25	0.2%	51	0.2%	51	0.2%	103	0.2%	103	0.2%	207	0.2%
4800	12	0.2%	25	0.2%	25	0.2%	51	0.2%	51	0.2%	103	0.2%
9600	6	-7.0%	12	0.2%	12	0.2%	25	0.2%	25	0.2%	51	0.2%
14.4K	3	8.5%	8	-3.5%	8	-3.5%	16	2.1%	16	2.1%	34	-0.8%
19.2K	2	8.5%	6	-7.0%	6	-7.0%	12	0.2%	12	0.2%	25	0.2%
28.8K	1	8.5%	3	8.5%	3	8.5%	8	-3.5%	8	-3.5%	16	2.1%
38.4K	1	-18.6%	2	8.5%	2	8.5%	6	-7.0%	6	-7.0%	12	0.2%
57.6K	-	-	1	8.5%	1	8.5%	3	8.5%	3	8.5%	8	-3.5%
76.8K	-	-	1	-18.6%	1	-18.6%	2	8.5%	2	8.5%	6	-7.0%
115.2K	-	-	-	-	-	-	1	8.5%	1	8.5%	3	8.5%
230.4K	-	-	-	-	-	-	-	-	-	-	1	8.5%
250K	-	-	-	-	-	-	-	-	-	-	1	0.0%
0.5M	-	-	-	-	-	-	-	-	-	-	-	-
Baud Rate	fOSC =8.00MHz				fOSC =16.00MHz							
	U2X=0		U2X=1		U2X=0		U2X=1					
	UBAUD	ERROR	UBAUD	ERROR	UBAUD	ERROR	UBAUD	ERROR				
2400	207	0.2%	-	-	-	-	-	-				
4800	103	0.2%	207	0.2%	207	0.2%	-	-				
9600	51	0.2%	103	0.2%	103	0.2%	207	0.2%				
14.4K	34	-0.8%	68	0.6%	68	0.6%	138	-0.1%				
19.2K	25	0.2%	51	0.2%	51	0.2%	103	0.2%				
28.8K	16	2.1%	34	-0.8%	34	-0.8%	68	0.6%				
38.4K	12	0.2%	25	0.2%	25	0.2%	51	0.2%				
57.6K	8	-3.5%	16	2.1%	16	2.1%	34	-0.8%				
76.8K	6	-7.0%	12	0.2%	12	0.2%	25	0.2%				
115.2K	3	8.5%	8	-3.5%	8	-3.5%	16	2.1%				
230.4K	1	8.5%	3	8.5%	3	8.5%	8	-3.5%				
250K	1	0.0%	3	0.0%	3	0.0%	7	0.0%				
0.5M	-	-	1	0.0%	1	0.0%	3	0.0%				

(b) fOSC = Multiples of 1.8432MHz

Baud Rate	fOSC =1.8432MHz (x1)				fOSC =3.6864MHz (x2)				fOSC =7.3728MHz (x4)			
	U2X=0		U2X=1		U2X=0		U2X=1		U2X=0		U2X=1	
	UBAUD	ERROR	UBAUD	ERROR	UBAUD	ERROR	UBAUD	ERROR	UBAUD	ERROR	UBAUD	ERROR
2400	47	0.0%	95	0.0%	95	0.0%	191	0.0%	191	0.0%	-	-
4800	23	0.0%	47	0.0%	47	0.0%	95	0.0%	95	0.0%	191	0.0%
9600	11	0.0%	23	0.0%	23	0.0%	47	0.0%	47	0.0%	95	0.0%
14.4K	7	0.0%	15	0.0%	15	0.0%	31	0.0%	31	0.0%	63	0.0%
19.2K	5	0.0%	11	0.0%	11	0.0%	23	0.0%	23	0.0%	47	0.0%
28.8K	3	0.0%	7	0.0%	7	0.0%	15	0.0%	15	0.0%	31	0.0%
38.4K	2	0.0%	5	0.0%	5	0.0%	11	0.0%	11	0.0%	23	0.0%
57.6K	1	-25.0%	3	0.0%	3	0.0%	7	0.0%	7	0.0%	15	0.0%
76.8K	1	0.0%	2	0.0%	2	0.0%	5	0.0%	5	0.0%	11	0.0%
115.2K	-	-	1	0.0%	1	0.0%	3	0.0%	3	0.0%	7	0.0%
230.4K	-	-	-	-	-	-	1	0.0%	1	0.0%	3	0.0%
250K	-	-	-	-	-	-	1	-7.8%	1	-7.8%	3	-7.8%
0.5M	-	-	-	-	-	-	-	-	-	-	1	-7.8%
Baud Rate	fOSC =11.0592MHz (x6)				fOSC =14.7456MHz (x8)							
	U2X=0		U2X=1		U2X=0		U2X=1					
	UBAUD	ERROR	UBAUD	ERROR	UBAUD	ERROR	UBAUD	ERROR				
2400	-	-	-	-	-	-	-	-				
4800	143	0.0%	-	-	191	0.0%	-	-				
9600	71	0.0%	143	0.0%	95	0.0%	191	0.0%				
14.4K	47	0.0%	95	0.0%	63	0.0%	127	0.0%				
19.2K	35	0.0%	71	0.0%	47	0.0%	95	0.0%				
28.8K	23	0.0%	47	0.0%	31	0.0%	63	0.0%				
38.4K	17	0.0%	35	0.0%	23	0.0%	47	0.0%				
57.6K	11	0.0%	23	0.0%	15	0.0%	31	0.0%				
76.8K	8	0.0%	17	0.0%	11	0.0%	23	0.0%				
115.2K	5	0.0%	11	0.0%	7	0.0%	15	0.0%				
230.4K	2	0.0%	5	0.0%	3	0.0%	7	0.0%				
250K	2	-7.8%	5	-7.8%	3	-7.8%	6	5.3%				
0.5M	-	-	2	-7.8%	1	-7.8%	3	-7.8%				

11.8 I²C

11.8.1 Overview

The I²C is one of industrial standard serial communication protocols, and which uses 2 bus lines Serial Data Line (SDA) and Serial Clock Line (SCL) to exchange data. Because both SDA and SCL lines are open-drain output, each line needs pull-up resistor. The features are as shown below.

- Compatible with I²C bus standard
- Multi-master operation
- Up to 400 KHz data transfer speed
- 7 bit address
- Support 2 slave addresses
- Both master and slave operation
- Bus busy detection

11.8.2 Block Diagram

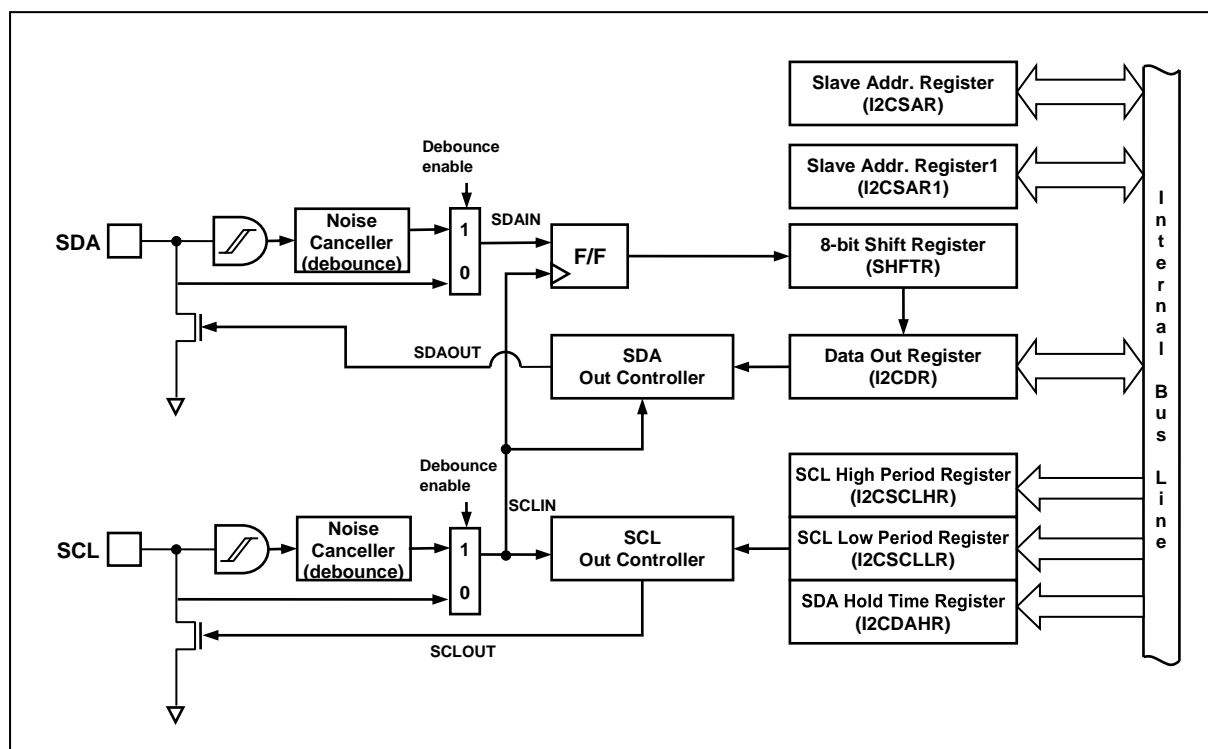

Figure 11-25 I²C Block Diagram

11.8.3 I²C Bit Transfer

The data on the SDA line must be stable during HIGH period of the clock, SCL. The HIGH or LOW state of the data line can only change when the clock signal on the SCL line is LOW. The exceptions are START(S), repeated START(Sr) and STOP(P) condition where data line changes when clock line is high.

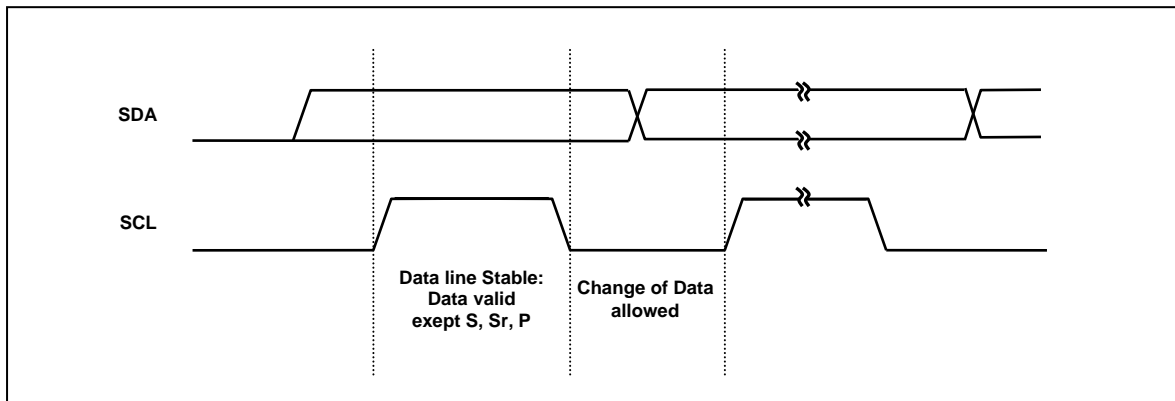

Figure 11-26 Bit Transfer on the I²C-Bus

11.8.4 Start / Repeated Start / Stop

One master can issue a START (S) condition to notice other devices connected to the SCL, SDA lines that it will use the bus. A STOP (P) condition is generated by the master to release the bus lines so that other devices can use it.

A high to low transition on the SDA line while SCL is high defines a START (S) condition.

A low to high transition on the SDA line while SCL is high defines a STOP (P) condition.

START and STOP conditions are always generated by the master. The bus is considered to be busy after START condition. The bus is considered to be free again after STOP condition, ie, the bus is busy between START and STOP condition. If a repeated START condition (Sr) is generated instead of STOP condition, the bus stays busy. So, the START and repeated START conditions are functionally identical.

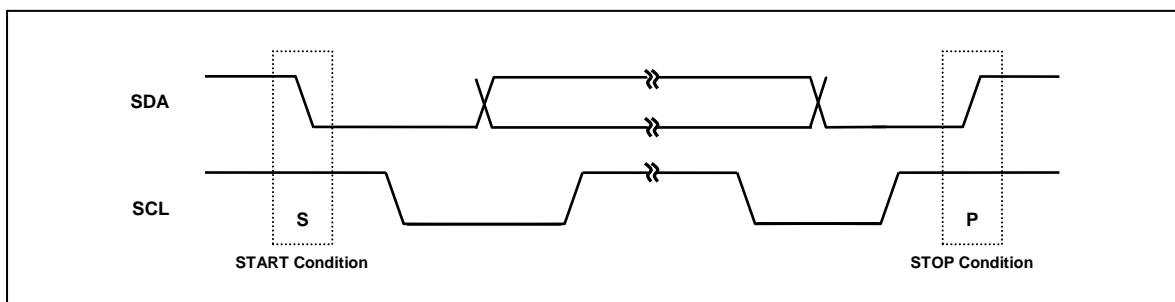

Figure 11-27 START and STOP Condition

11.8.5 Data Transfer

Every byte put on the SDA line must be 8-bits long. The number of bytes that can be transmitted per transfer is unlimited. Each byte has to be followed by an acknowledge bit. Data is transferred with the most significant bit (MSB) first. If a slave can't receive or transmit another complete byte of data until it has performed some other function, it can hold the clock line SCL LOW to force the master into a wait state. Data transfer then continues when the slave is ready for another byte of data and releases clock line SCL.

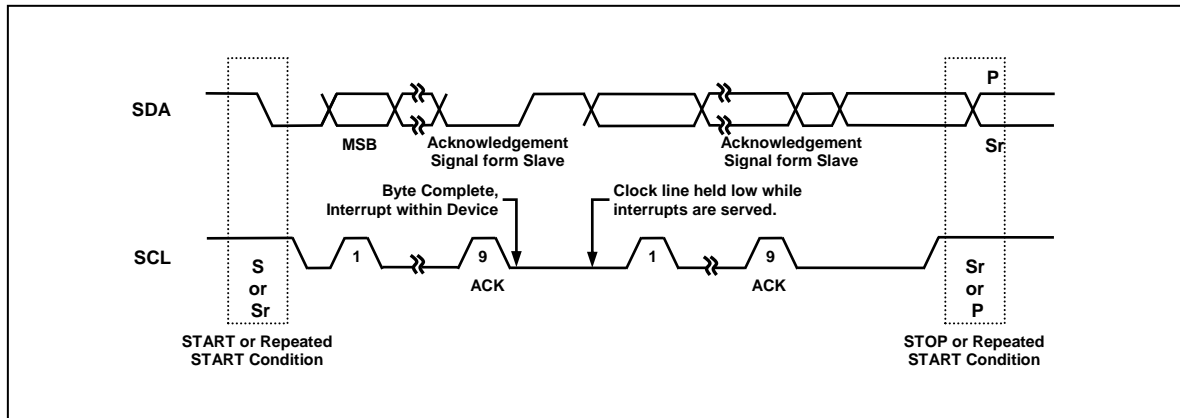

Figure 11-28 Data Transfer on the I²C-Bus

11.8.6 Acknowledge

The acknowledge related clock pulse is generated by the master. The transmitter releases the SDA line (HIGH) during the acknowledge clock pulse. The receiver must pull down the SDA line during the acknowledge clock pulse so that it remains stable LOW during the HIGH period of this clock pulse. When a slave is addressed by a master (Address Packet), and if it is unable to receive or transmit because it's performing some real time function, the data line must be left HIGH by the slave. And also, when a slave addressed by a master is unable to receive more data bits, the slave receiver must release the SDA line (Data Packet). The master can then generate either a STOP condition to abort the transfer, or a repeated START condition to start a new transfer.

If a master receiver is involved in a transfer, it must signal the end of data to the slave transmitter by not generating an acknowledge on the last byte that was clocked out of the slave. The slave transmitter must release the data line to allow the master to generate a STOP or repeated START condition.

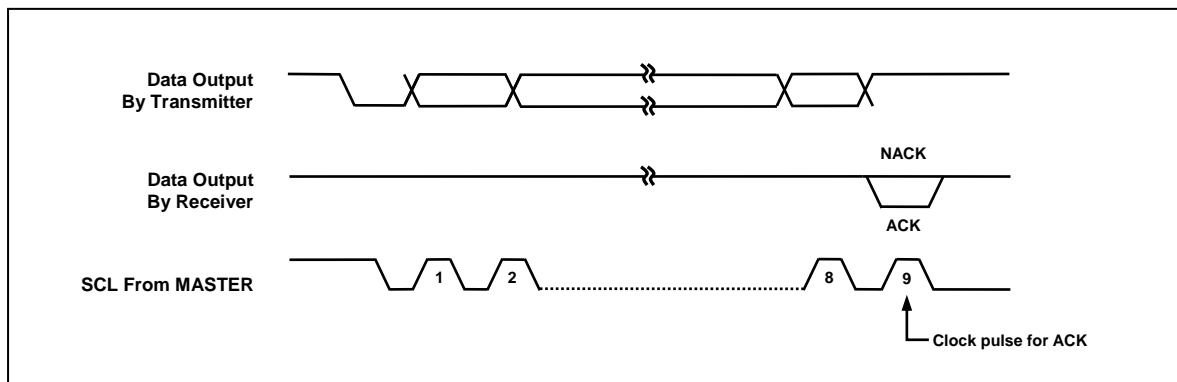

Figure 11-29 Acknowledge on the I²C-Bus

11.8.7 Synchronization / Arbitration

Clock synchronization is performed using the wired-AND connection of I²C interfaces to the SCL line. This means that a HIGH to LOW transition on the SCL line will cause the devices concerned to start counting off their LOW period and it will hold the SCL line in that state until the clock HIGH state is reached. However the LOW to HIGH transition of this clock may not change the state of the SCL

line if another clock is still within its LOW period. In this way, a synchronized SCL clock is generated with its LOW period determined by the device with the longest clock LOW period, and its HIGH period determined by the one with the shortest clock HIGH period.

A master may start a transfer only if the bus is free. Two or more masters may generate a START condition. Arbitration takes place on the SDA line, while the SCL line is at the HIGH level, in such a way that the master which transmits a HIGH level, while another master is transmitting a LOW level will switch off its DATA output state because the level on the bus doesn't correspond to its own level. Arbitration continues for many bits until a winning master gets the ownership of I²C bus. Its first stage is comparison of the address bits.

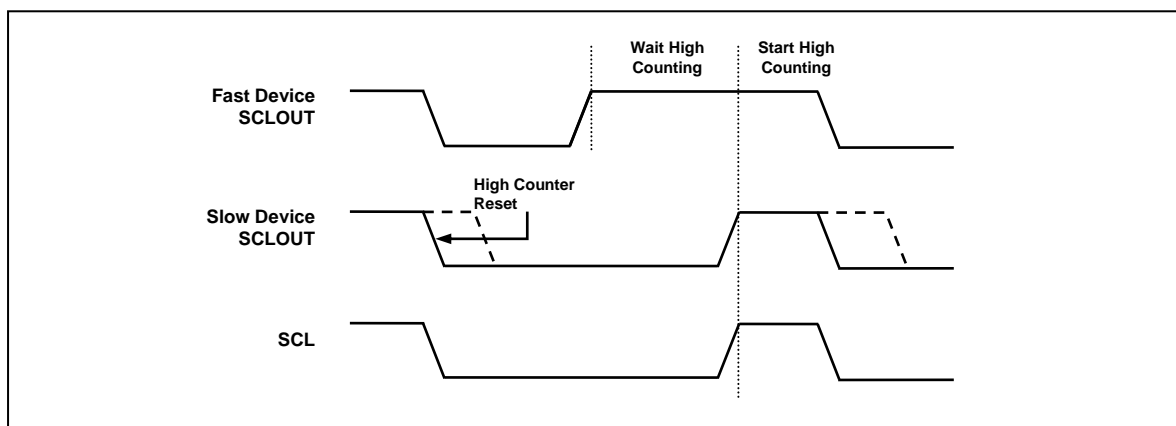

Figure 11-30 Clock Synchronization during Arbitration Procedure

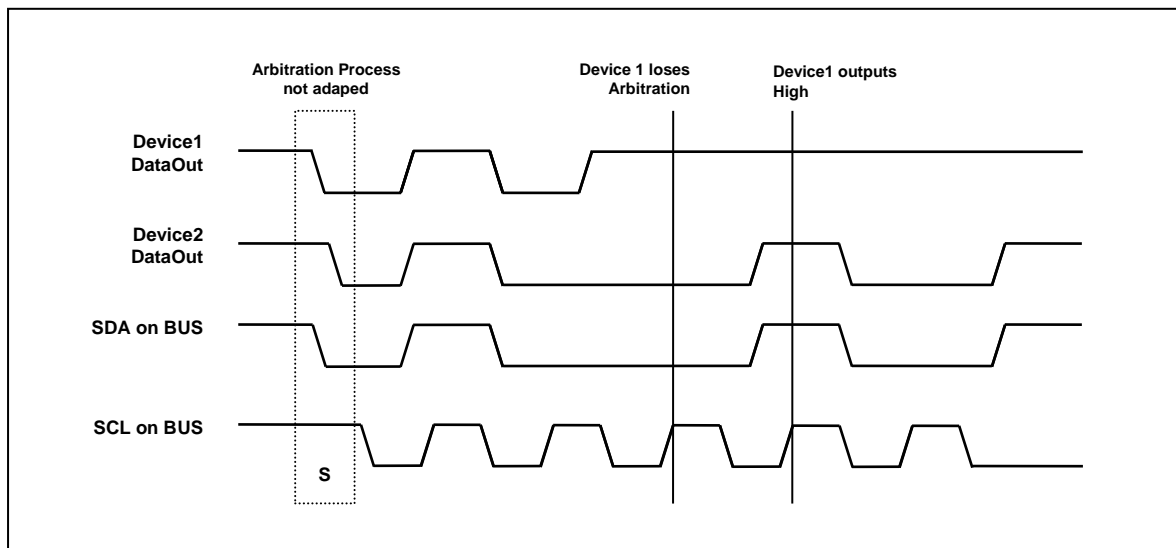

Figure 11-31 Arbitration Procedure of Two Masters

11.8.8 I2C Block Operation

The I2C block as peripheral design is independently operating with main CPU operation. The operation of I2C block does a byte unit of I2C frame. After finishing a byte operation (transmit/receive data and clock) on I2C bus system, I2C block generate I2C interrupt for next byte operation. The I2C Interrupt service manage I2C block with the SFR registers, data load/read register (I2CDR) from/to

I2C bus system, block control register (I2CMR), the state register (I2CSR) contained operation result. An operation unit of I2C H/W block generates/ receive 9 SCL clock that are for 8 bits data and an ACK. I2C block send / receive ACK signal at 9th clock of SCL according to I2C specification.

The I2C application software initialize I2C block condition depended on clock system, I2C devices condition after system power on.

An application S/W prepares I2C bus communication resource on RAM buffers. If it is to set the start flag in I2CMR register. I2C block start to generate start signal and send a Slave address to slave device. All steps of I2C communication service except start signal and slave address is done by H/W block and I2C Interrupt service. Therefore main application software can reduce time resource while I2C Data write/read operation.

I2C block design supports both functions of master/ Slave on the same block. In case of Master device it generate SCL clock to slave device and the case of slave mode receive SCL clock from master device.

I2C block decide SDA data direction with the data direction bit (R/W) of device address in both cases of master and slave mode(TMODE bit 0-> Receive, 1-> Transmit)

Note) When an I²C interrupt is generated by I2C block, IIF flag in I2CMR register is set and it is cleared by writing any value to I2CSR. When I²C interrupt occurs, the SCL line is hold LOW for reading/writing I2CDR register and control I2CMR until writing any value to I2CSR. When the IIF flag is set, the I2CSR contains a value for the state of the I2C bus. According to the value in I2CSR, software can decide what to do next.

I²C can operate in 4 modes by configuring master/slave, transmitter/receiver.

I2C block initialization process

After power ON, it is necessary to have to initialize I2C block for that I2C Block provide I2C Slave device service

- ① I2C block will start operation (operation clock active) by setting IICEN bit on I2CMR register.
I2CMR = IICEN; // I2C block enable
- ② Reset I2C block by setting RESET bit on I2CMR register.
I2CMR = RESET; // Reset I2C block by S/W
- ③ Depended on I2C devices, it shall define I2C SCL max clock and write the value of SCL Low /high time and SDA hold time on I2CSCLLR, I2CSCLHR, I2CSDAHR as following diagram

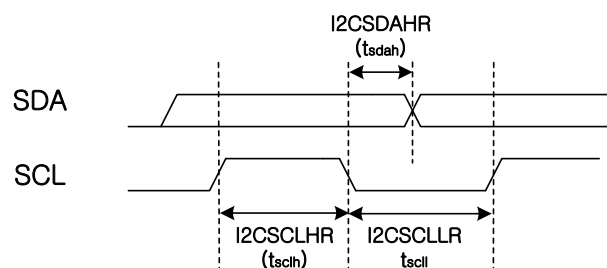

The timing values are calculated as the follow formula

$$tscll = tsysclk (4 \times I2CSCLLR + 1) \rightarrow \text{SCL clock low time}$$

$t_{sclh} = t_{sysclk} (4 \times I2CSCLHR + 3) \rightarrow$ SCL clock High time

$t_{sdah} = t_{sysclk} (I2CSDAHR + 1) \rightarrow$ SDA data hold time after falling edge of SCL

* t_{sysclk} = system clock timing

Ex) In case of I2C clock (100KHz) and system clock(4MHz), each of t_{scll} , t_{sclh} times is 5uSec and t_{sdah} is 2.5 uSec.

$I2CSCLLR = 5; I2CSCLHR = 4; I2CSDAHR = 9;$

- ④ It is to decide I2C Slave device address and write the address to I2CSAR

$I2CSAR = SELF_ADDRESS;$

- ⑤ Finally be ready to get I2C data from I2C bus system as slave device by setting I2C interrupt enable, I2C block enable, ACK enable bits on I2CMR register

$I2CMR = IICEN+INTEN+ACKEN; //$ I2C interrupt enable

I2C interrupt Service

I2C Interrupt service will use for next management action and data load/read from I2C block after I2C H/W block operation (as I2C Master/ Slave device). Because I2C block acts I2C data receiving/writing as a byte unit, I2C block make I2C interrupt for next action of I2C block. While the interrupt happen, I2C block serve the state of I2C bus condition and operation result to I2CSR register. Interrupt service look both registers of I2CMR and I2CSR and do next steps (Save a data from I2CDR, load a data to I2CDR, make STOP condition or Re-start so on).

I2C Interrupt occur at after the following cases

1) As I2C Master Device

- sending a byte on I2CDR register after setting Start bit. (GCALL interrupt)
- sending a byte on I2CDR register after write to I2CSR.(TEND interrupt)
- receiving a byte on I2CDR after write to I2CSR (TEND interrupt)
- Occurring an arbitration loss (MLOST interrupt)
- detecting Stop condition (STOP interrupt)

2) As I2C Slave device

- getting start condition and same device address from a Master (SSEL interrupt)
- sending a byte on I2CDR register after write to I2CSR.(TEND interrupt)
- receiving a byte on I2CDR after write to I2CSR (TEND interrupt)
- detecting Stop condition (STOP interrupt)

Depended on above results I2C service provide services to read/write data from/to I2CDR, generate STOP condition, make next I2C Block action by writing a data to I2CSR register.

Bus arbitration of I2C block processes from I2C bus start condition to last data of I2C data frame. If getting an arbitration loss (MLOST interrupt), I2C interrupt service make I2C block Reset for bus free.

Master transmitter

Main software is to have write/read data to/from slave I2C device. The software has to be ready to get number of data with internal RAM or sending data on internal RAM according to I2C bus protocol type of Slave device. It writes Slave Address to I2CDR register in I2C Block and then if it set START bit on I2CMR register I2C block send slave address with SCL clock to slave device. I2C Block takes master mode (MASTER bit -> 1) and take the read/write state (TMODE bit , read(0), write(1)) according to the data direction bit (R/W) of device address.

The following is examples software for the case of master mode

Master write

```
I2CMR = IICEN+INTEN;           // set I2C block( enable IIC block, I2C interrupt)
I2CDR = Slave Address + Write mode; // load target Salve Address
I2CMR |= SRT;                   // generate start condition and send slave address
```

I2C Interrupt Service

```
If(Master Mode) and (TMODE)
  If( ACK and GCALL or ACK and TEND )
    If ( Not End of Data )
      I2CDR = NEXT DATA;      // load target Salve Address
      I2CSR = 0xFF;            // Byte transmit start
    ELSE
      I2CMR = IICEN+INTEN+STP; // STOP generation
    ELSE
      Initialize I2C block      // if have ACK error, any error
End of I2C interrupt service
```

Master Read (without sub address of Slave device)

```
I2CMR = IICEN+INTEN;           // start generate
I2CDR = Slave Address + Read mode; // load target Salve Address
I2CMR |= SRT;                   // generate start condition
```

I2C Interrupt Service

```
If (Master mode) and ( /TMODE)
  If( ACK and GCALL )
    I2CMR |= ACKEN              // After receive data, generate ACK
    I2CSR = 0xFF;              // Byte transmit start
  ELSE
    if ACK and TEND )
      If ( Not End of Data )
        If(LAST Data)
          I2CMR &= ~ACKEN      // After receive data, generate ACK
          I2C_buffer = I2CDR    // read
          I2CSR = 0xFF;        // Byte transmit start
        ELSE
          If( ~ACK and TEND)
            I2CMR = IICEN+INTEN+STP; // STOP generation
            I2CSR = 0xFF;        // Byte transmit start
          ELSE
            Initialize I2C block // if have ACK error, any error
End of I2C interrupt service
```

Slave Receiver

I2C Block that is under IIC enable and INTEN enable on I2CMR is monitoring I2C bus lines for being a start condition and self-address with I2CSAD. To have both signals of start signal and getting self-address, I2C block generate I2C interrupt with the status bits (SSEL, BUSY RXACK, SLAVE mode ..) after sending ACK signal. At the time **I2C block control SCL line to low state** for ready to get/handle next i2c data. If I2C block by I2C interrupt service is ready for next step, it is to release the SCL line to high state for getting next SCL clock from the master. I2C Block decide bus direction (data receive/transmission) by data direction (R/W) bit in Slave address from master. The state of bus direction is on TMOD bit on I2CSR register. If the master generate Stop condition I2C block receive

STOP condition and generate I2C interrupt. I2C interrupt service write any data to I2CSR and finish Slave operation. I2C interrupt service and state register condition is diagrammed in Figure xxxx.

I2C Interrupt service

I2C Slave service

```
    if((Getting SSEL and send ACK) // received Self-address form master
```

```
        if(TMODE) // data direction (R/W)
```

```
            I2CDR=I2C_TXData // Transmission mode, Load data
```

```
        else
```

```
    I2C_RXData =I2CDR
```

```
    else
```

```
        if (Get STOP condition)
```

```
        else
```

```
            if (TMODE) // data direction (R/W)
```

```
                I2CDR= I2C_TXData // Transmission mode, Load data
```

```
            else
```

```
                I2C_RXData =I2CDR // Save received Data
```

```
    I2CSR=0xff;
```

11.8.9 Register Map

Name	Address	Dir	Default	Description
I2CMR	DAH	R/W	00H	I ² C Mode Control Register
I2CSR	DBH	R	00H	I ² C Status Register
I2CSCLLR	DCH	R/W	3FH	SCL Low Period Register
I2CSCLHR	DDH	R/W	3FH	SCL High Period Register
I2CSDAHR	DEH	R/W	01H	SDA Hold Time Register
I2CDR	DFH	R/W	FFH	I ² C Data Register
I2CSAR	D7H	R/W	00H	I ² C Slave Address Register
I2CSAR1	D6H	R/W	00H	I ² C Slave Address Register 1

11.8.10 I²C Register Description

I²C Registers are composed of I²C Mode Control Register (I2CMR), I²C Status Register (I2CSR), SCL Low Period Register (I2CSCLLR), SCL High Period Register (I2CSCLHR), SDA Hold Time Register (I2CSDAHR), I²C Data Register (I2CDR), and I²C Slave Address Register (I2CSAR).

11.8.11 Register Description for I²C

I2CMR (I²C Mode Control Register) : DAH

7	6	5	4	3	2	1	0
IIF	IICEN	RESET	INTEN	ACKEN	MASTER	STOP	START
RW	RW	RW	RW	RW	R	RW	RW

Initial value : 00H

IIF	This is interrupt flag bit. 0 No interrupt is generated or interrupt is cleared 1 An interrupt is generated
IICEN	Enable I ² C Function Block (by providing clock) 0 I ² C is inactive 1 I ² C is active
RESET	Initialize internal registers of I ² C. 0 No operation 1 Initialize I ² C, auto cleared
INTEN	Enable interrupt generation of I ² C. 0 Disable interrupt, operates in polling mode 1 Enable interrupt
ACKEN	Controls ACK signal generation at ninth SCL period. Note) ACK signal is output (SDA=0) for the following 3 cases. When received address packet equals to SLA bits in I2CSAR When received address packet equals to value 0x00 with GCALL enabled When I ² C operates as a receiver (master or slave) 0 No ACK signal is generated (SDA=1) 1 ACK signal is generated (SDA=0)
MASTER	Represent operating mode of I ² C

- 0 I²C is in slave mode
- 1 I²C is in master mode
- STOP** When I²C is master, generates STOP condition.
- 0 No operation
- 1 STOP condition is to be generated
- START** When I²C is master, generates START condition.
- 0 No operation
- 1 START or repeated START condition is to be generated

I2CSR (I²C Status Register) : DBH

7	6	5	4	3	2	1	0
GCALL	TEND	STOP	SSEL	MLOST	BUSY	TMODE	RXACK
R	R	R	R	R	R	R	R

Initial value : 00H

- GCALL** This bit has different meaning depending on whether I²C is master or slave. Note 1)
When I²C is a master, this bit represents whether it received AACK (Address ACK) from slave.
When I²C is a slave, this bit is used to indicate general call.
 - 0 No AACK is received (Master mode)
 - 1 AACK is received (Master mode)
 - 0 Received address is not general call address (Slave mode)
 - 1 General call address is detected (Slave mode)
- TEND** This bit is set when 1-Byte of data is transferred completely. Note 1)
 - 0 1 byte of data is not completely transferred
 - 1 1 byte of data is completely transferred
- STOP** This bit is set when STOP condition is detected. Note 1)
 - 0 No STOP condition is detected
 - 1 STOP condition is detected
- SSEL** This bit is set when I²C is addressed by other master. Note 1)
 - 0 I²C is not selected as slave
 - 1 I²C is addressed by other master and acts as a slave
- MLOST** This bit represents the result of bus arbitration in master mode. Note 1)
 - 0 I²C maintains bus mastership
 - 1 I²C has lost bus mastership during arbitration process
- BUSY** This bit reflects bus status.
 - 0 I²C bus is idle, so any master can issue a START condition
 - 1 I²C bus is busy
- TMODE** This bit is used to indicate whether I²C is transmitter or receiver.
 - 0 I²C is a receiver
 - 1 I²C is a transmitter
- RXACK** This bit shows the state of ACK signal.
 - 0 No ACK is received
 - 1 ACK is generated at ninth SCL period

Note 1) These bits can be source of interrupt.

When an I²C interrupt occurs except for STOP interrupt, the SCL line is hold LOW. To release SCL, write arbitrary value to I2CSR. When I2CSR is written, the TEND, STOP, SSEL, LOST, RXACK bits are cleared.

I2CSCLR (SCL Low Period Register) : DCH

7	6	5	4	3	2	1	0
SCLL7	SCLL6	SCLL5	SCLL4	SCLL3	SCLL2	SCLL1	SCLL0
RW	RW	RW	RW	RW	RW	RW	RW

Initial value : 3FH

SCLL[7:0] This register defines the LOW period of SCL when I²C operates in master mode. The base clock is SCLK, the system clock, and the period is calculated by the formula : $t_{SCLK} \times (4 \times SCLL + 1)$ where t_{SCLK} is the period of SCLK.

I2CSCLR (SCL High Period Register) : DDH

7	6	5	4	3	2	1	0
SCLH7	SCLH6	SCLH5	SCLH4	SCLH3	SCLH2	SCLH1	SCLH0
RW	RW	RW	RW	RW	RW	RW	RW

Initial value : 3FH

SCLH[7:0] This register defines the HIGH period of SCL when I²C operates in master mode. The base clock is SCLK, the system clock, and the period is calculated by the formula : $t_{SCLK} \times (4 \times SCLH + 3)$ where t_{SCLK} is the period of SCLK.

So, the operating frequency of I²C in master mode (fI2C) is calculated by the following equation.

$$fI2C = \frac{1}{t_{SCLK} \times (4 (SCLL + SCLH) + 4)}$$

I2CSDAHR (SDA Hold Time Register) : DEH

7	6	5	4	3	2	1	0
SDAH7	SDAH6	SDAH5	SDAH4	SDAH3	SDAH2	SDAH1	SDAH0
RW	RW	RW	RW	RW	RW	RW	RW

Initial value : 01H

SDAH[7:0] This register is used to control SDA output timing from the falling edge of SCL. Note that SDA is changed after $t_{SCLK} \times SDAH$. In master mode, load half the value of SCLL to this register to make SDA change in the middle of SCL. In slave mode, configure this register regarding the frequency of SCL from master. The SDA is changed after $t_{SCLK} \times (SDAH + 1)$. So, to insure normal operation in slave mode, the value $t_{SCLK} \times (SDAH + 1)$ must be smaller than the period of SCL.

I2CDR (I²C Data Register) : DFH

7	6	5	4	3	2	1	0
ICD7	ICD6	ICD5	ICD4	ICD3	ICD2	ICD1	ICD0
RW	RW	RW	RW	RW	RW	RW	RW

Initial value : FFH

ICD[7:0] When I²C is configured as a transmitter, load this register with data to be transmitted. When I²C is a receiver, the received data is

stored into this register.

I2CSAR (I²C Slave Address Register) : D7H

7	6	5	4	3	2	1	0
SLA7	SLA6	SLA5	SLA4	SLA3	SLA2	SLA1	GCALLEN
RW	RW	RW	RW	RW	RW	RW	RW

Initial value : 00H

SLA[7:1] These bits configure the slave address of this I²C module when I²C operates in slave mode.

GCALLEN This bit decides whether I²C allows general call address or not when I²C operates in slave mode.

0 Ignore general call address

1 Allow general call address

I2CSAR1 (I²C Slave Address Register 1) : D6H

7	6	5	4	3	2	1	0
SLA7	SLA6	SLA5	SLA4	SLA3	SLA2	SLA1	GCALLEN
RW	RW	RW	RW	RW	RW	RW	RW

Initial value : 00H

SLA[7:1] These bits configure the slave address of this I²C module when I²C operates in slave mode.

GCALLEN This bit decides whether I²C allows general call address or not when I²C operates in slave mode.

0 Ignore general call address

1 Allow general call address

11.9 12-Bit A/D Converter

11.9.1 Overview

The analog-to-digital converter (A/D) allows conversion of an analog input signal to a corresponding 12-bit digital value. The A/D module has 8 analog inputs. The output of the multiplexer is the input into the converter, which generates the result via successive approximation. The A/D module has four registers which are the control register ADCM (A/D Converter Mode Register), ADCM2 (A/D Converter Mode Register 2) and A/D result register ADCHR (A/D Converter Result High Register) and ADCLR (A/D Converter Result Low Register). It is selected for the corresponding channel to be converted by setting ADSEL[3:0]. To executing A/D conversion, ADST bit sets to '1'. The register ADCHR and ADCLR contains the results of the A/D conversion. When the conversion is completed, the result is loaded into the ADCHR and ADCLR, the A/D conversion status bit AFLAG is set to '1', and the A/D interrupt is set. For processing A/D conversion, AFLAG bit is read as '0'. If using STBY (power down) bit, the ADC is disabled. Also internal timer, external generating event, comparator, the trigger of timer1pwm and etc. can start ADC regardless of interrupt occurrence.

$$\text{ADC Conversion Time} = \text{ADCLK} * 60 \text{ cycles}$$

After STBY bit is reset (ADC power enable) and it is restarted, during some cycle, ADC conversion value may have an inaccurate value.

11.9.2 Block Diagram

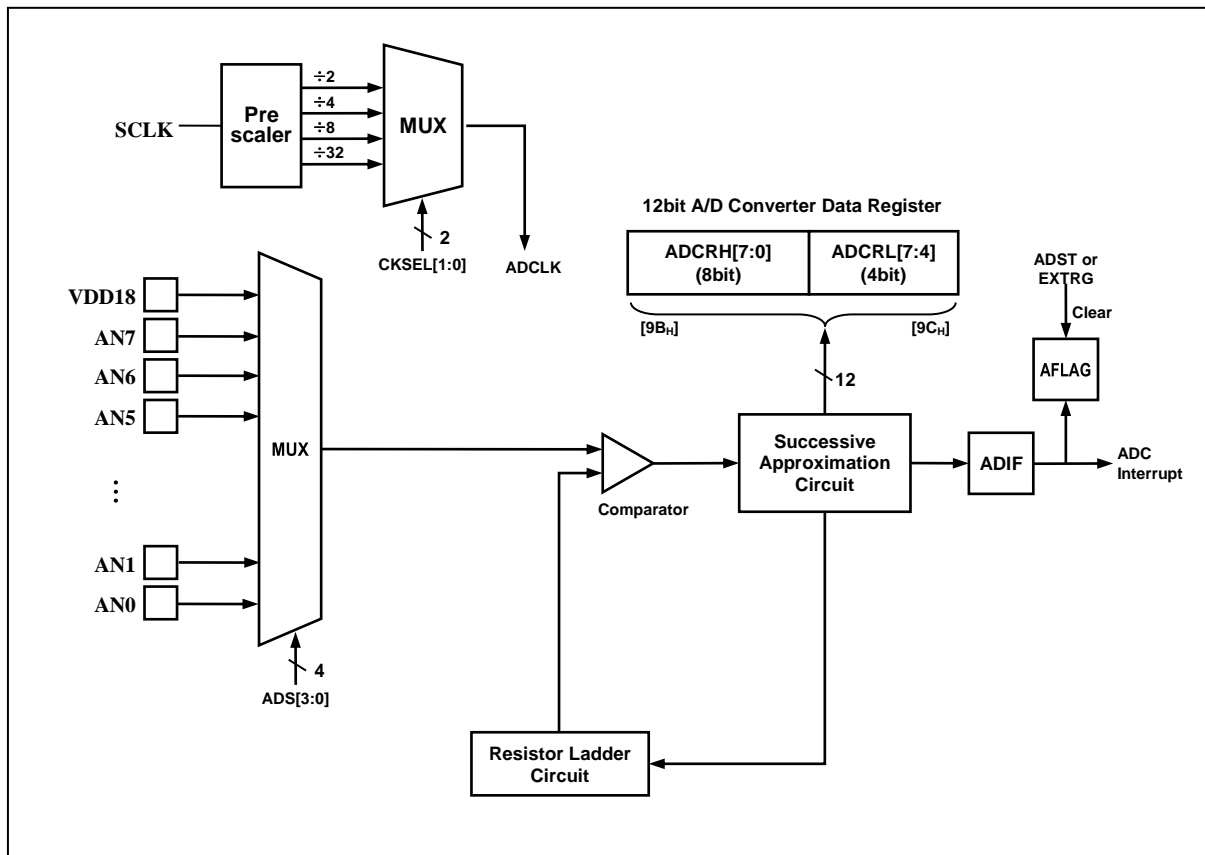

Figure 11-32 ADC Block Diagram

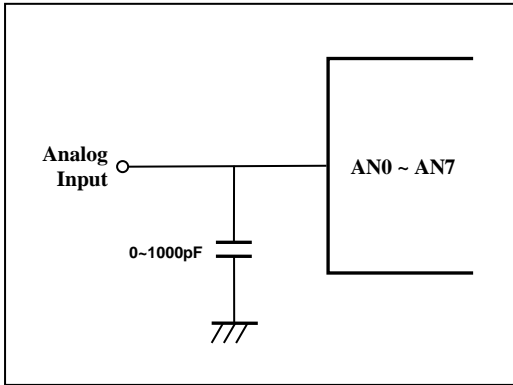

Figure 11-33 A/D Analog Input Pin Connecting Capacitor

11.9.3 ADC Operation

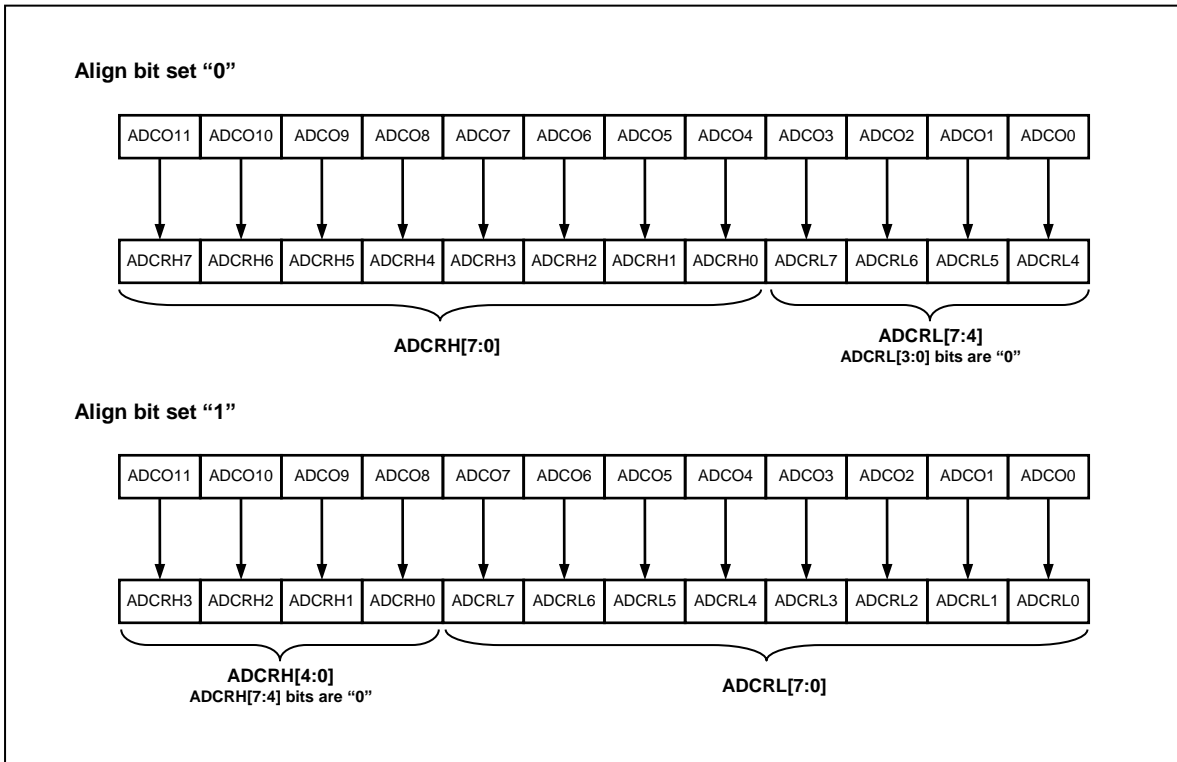

Figure 11-34 ADC Operation for Align Bit

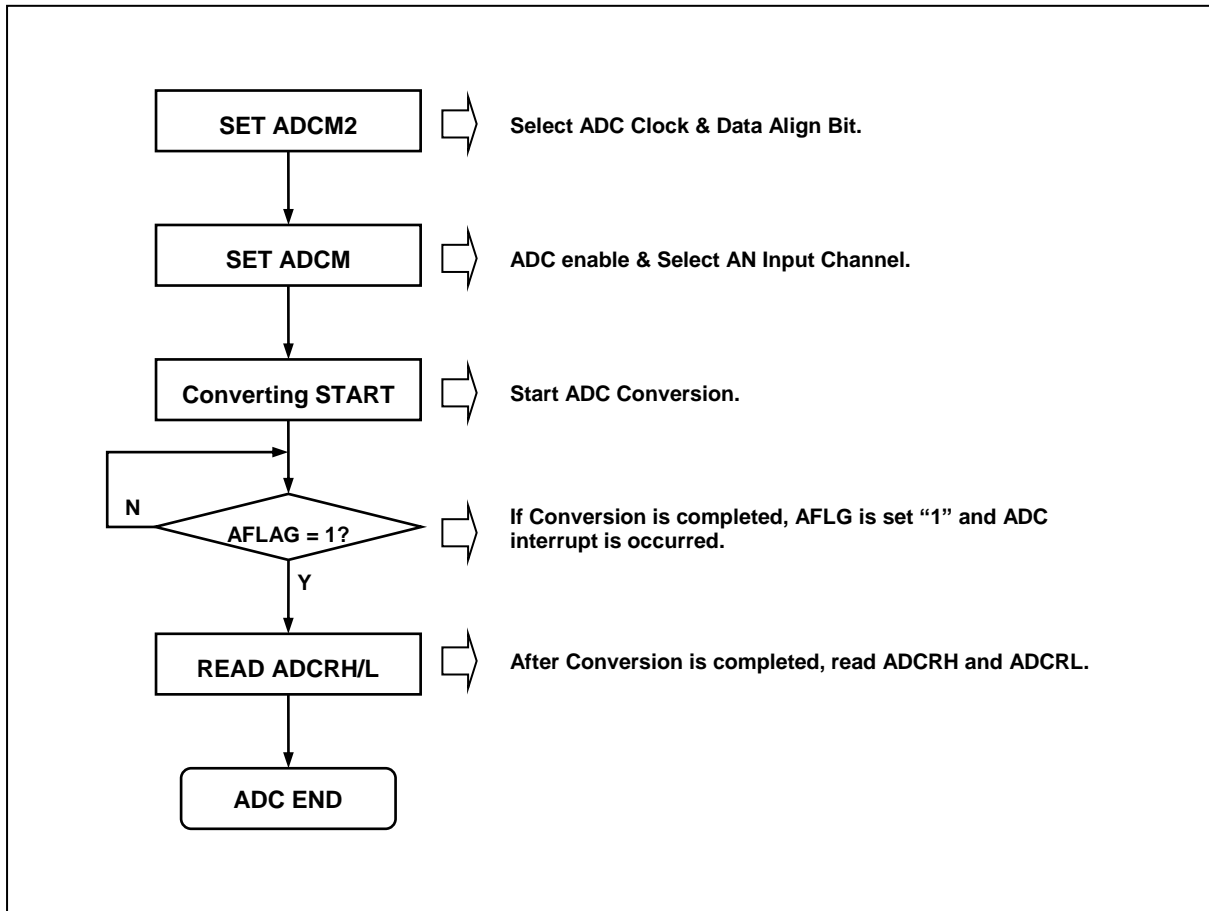

Figure 11-35 Converter Operation Flow

11.9.4 Register Map

Name	Address	Dir	Default	Description
ADCM	D1H	R/W	8FH	A/D Converter Mode Register
ADCM2	D2H	R/W	02H	A/D Converter Mode 2 Register
ADCRL	D3H	R	-	A/D Converter Result Low Register
ADCRH	D4H	R	-	A/D Converter Result High Register

11.9.5 ADC Register Description

The ADC Register consists of A/D Converter Mode Register (ADCM), A/D Converter Result High Register (ADCRH), A/D Converter Result Low Register (ADCRL), A/D Converter Mode 2 Register (ADCM2).

11.9.6 Register Description for ADC

ADCM (A/D Converter Mode Register) : D1H

7	6	5	4	3	2	1	0
STBY	ADST	REFSEL	AFLAG	ADSEL3	ADSEL2	ADSEL1	ADSEL0
R/W	R/W	R/W	R	R/W	R/W	R/W	R/W

Initial value : 8FH

STBY	Control operation of A/D standby (power down)				
0	ADC module enable				
1	ADC module disable (power down)				
ADST	Control A/D Conversion stop/start.				
0	ADC Conversion Stop				
1	ADC Conversion Start				
REFSEL	A/D Converter reference selection				
0	Internal Reference (Vref=VDD)				
1	Reserved (Test Only)				
AFLAG	A/D Converter operation state				
0	During A/D Conversion				
1	A/D Conversion finished				
ADSEL[3:0]	A/D Converter input selection				
	ADSEL3	ADSEL2	ADSEL1	ADSEL0	Description
		0	1	0	
0	0	0	0	0	Channel0(AN0)
0	0	0	0	1	Channel1(AN1)
0	0	0	1	0	Channel2(AN2)
0	0	0	1	1	Channel3(AN3)
0	1	0	0	0	Channel4(AN4)
0	1	0	0	1	Channel5(AN5)
0	1	1	0	0	Channel6(AN6)
0	1	1	1	0	Channel7(AN7)
1	0	0	0	0	Reserved
1	0	0	0	1	Reserved
1	0	1	0	0	Reserved
1	0	1	1	0	Reserved
1	1	0	0	0	Reserved
1	1	0	1	0	Reserved
1	1	1	0	0	Reserved
1	1	1	1	0	Reserved
1	1	1	1	1	VDD18 (Test Only)

ADCM2 (A/D Converter Mode 2 Register) : D2H

7	6	5	4	3	2	1	0
EXTRG	TSEL2	TSEL1	TSEL0	ALIGN	CKSEL2	CKSEL1	CKSEL0
R/W	R/W	R/W	R/W	R/W	R/W	R/W	R/W

Initial value : 02H

EXTRG	A/D External Trigger				
	A/D conversion Start by external Trigger, and Stop by clearing this bit				
0	A/D conversion Stop and External Trigger disable (default)				
1	External Trigger enable				
TSEL[2:0]	A/D Trigger Source selection				
	TSEL2	TSEL1	TSEL0	Description	
	0	0	0	PCI0 interrupt	
	0	0	1	PCI1 interrupt	
	0	1	0	I2C interrupt	
	0	1	1	USART RX interrupt	
	1	0	0	TIMER0 interrupt	
	1	0	1	TIMER1 interrupt	
	1	1	0	WDT interrupt	
	1	1	1	TOUCH interrupt	
ALIGN	A/D Converter data align selection.				
0	MSB align (ADCRH[7:0], ADCRL[7:4])				
1	LSB align (ADCRH[3:0], ADCRL[7:0])				
CKSEL[2:0]	A/D Converter Clock selection				
	CKSEL2	CKSEL1	CKSEL0	ADC Clock	ADC VDD
	0	0	0	fx/2	Test Only
	0	0	1	fx/4	3V~5V
	0	1	0	fx/8 (default)	3V~5V
	0	1	1	fx/16	3V~5V
	1	0	0	fx/32	2.7V~3V
	1	0	1	fx/64	2.4V~2.7V
	1	1	0	fx/64	2.4V~2.7V
	1	1	1	fx/64	2.4V~2.7V

- Note) 1. fx : system clock
 2. ADC clock must be used **Max. 3MHz greater than 4V.**
 3. ADC clock must be used **Max. 2MHz less than 4V.**

ADCRL (A/D Converter Result Low Register) : D3H

7	6	5	4	3	2	1	0
ADDM3 ADDL7	ADDM2 ADDL6	ADDM1 ADDL5	ADDM0 ADDL4	ADDL3	ADDL2	ADDL1	ADDL0
R	R	R	R	R	R	R	R

Initial value : xxH

ADDM[3:0] MSB align, A/D Converter Low result (4-bit)

ADDL[7:0] LSB align, A/D Converter Low result (8-bit)

ADCRH (A/D Converter Result High Register) : D4H

7	6	5	4	3	2	1	0
ADDM11	ADDM10	ADDM9	ADDM8	ADDM7 ADDL11	ADDM6 ADDL10	ADDM5 ADDL9	ADDM4 ADDL8
R	R	R	R	R	R	R	R

Initial value : xxH

ADDM[11:4] MSB align, A/D Converter High result (8-bit)

ADDL[11:8] LSB align, A/D Converter High result (4-bit)

11.10 24-Channel Touch Switch

11.10.1 Features

- . Self Capacitive Touch Key Sensor.
- . Total 24-channel Touch Key Support.
- . 16-bits Sensing Resolutions.
- . Fast Initial Self Calibration.
- . Key Detection Mode : Single/Multi-Mode.
- . Clock Frequency during Sensing Operation : 16MHz.
- . The Improvement of the SNR by Bias-Calibration in Analog Sensing Block..
- . VDD Operating Voltage : 2.7V ~ 5.5V.
- . Current Consumption@STOPmode : < 1uA.
- . Operation Temperature : -40°C ~ 85°C.

11.10.2 Block Diagram

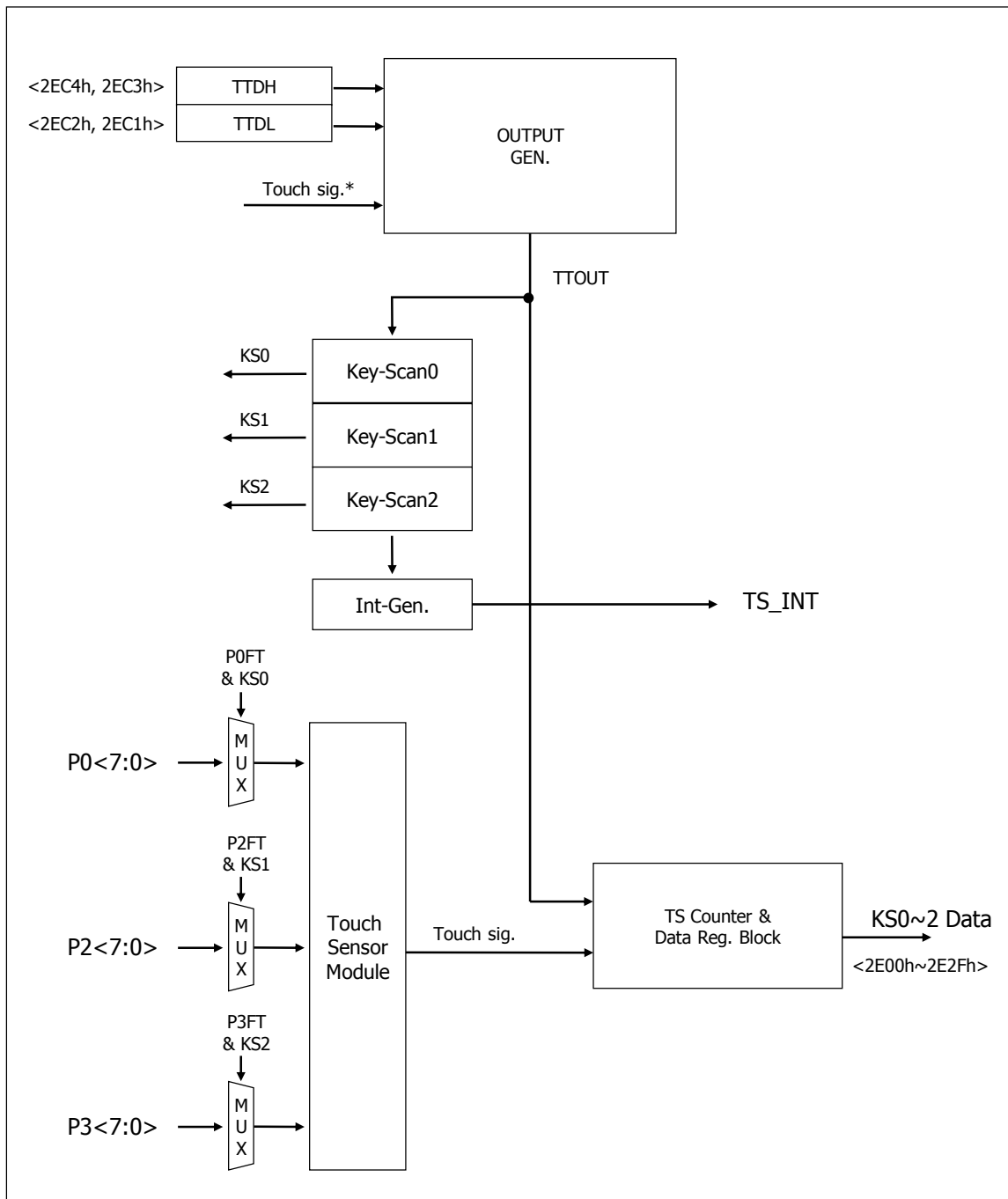

Figure 11-36 24 Channels Touch Switch Block Diagram

11.10.3 Register Map

Name	Address	Dir	Default	Description
TSCR	E2H	R/W	00H	Touch Sensing Interrupt Flag Register
TSTR	E3H	R/W	00H	Touch Sensing Test Register
KS00H	2E00H	R		Touch Sensing Data High Register
KS00L	2E01H	R		Touch Sensing Data Low Register
...				
KS27H	2E2EH	R		Touch Sensing Data High Register
KS27L	2E2FH	R		Touch Sensing Data Low Register
RSD00	2E40H	W	-	Resistor Selection Data Register
RSD01	2E41H	W	-	Resistor Selection Data Register
...				
RSD26	2E5EH	W	-	Resistor Selection Data Register
RSD27	2E5FH	W	-	Resistor Selection Data Register
TTMR	2EC0H	R/W	00H	Touch-Timer Mode Register
TTDLL	2EC1H	W	-	Touch Timer Data Low Register Low-Byte
TTDLH	2EC2H	W	-	Touch Timer Data Low Register High-Byte
TTDHL	2EC3H	W	-	Touch Timer Data High Register Low-Byte
TTDHH	2EC4H	W	-	Touch Timer Data High Register High-Byte
KENR	2EC5H	R/W	00H	Touch Key Enable Register
KSMR	2EC6H	R/W	00H	Touch Key Scan Register
FPCAL	2EC8H	R/W	00H	Functional Power Calibration Register
VCAL	2EC9H	R/W	00H	Voltage Calibration Register
CCAL	2ECAH	R/W	00H	Current Calibration Register for Frequency Control
TSCTL0	2ECBH	R/W	00H	Touch Sensor Control Register 0
TSCTL1	2ECCH	R/W	00H	Touch Sensor Control Register 1
P0FT	2ECDH	R/W	00H	P0 Port Touch Function Register
P2FT	2ECEH	R/W	00H	P2 Port Touch Function Register
P3FT	2ECFH	R/W	00H	P3 Port Touch Function Register

11.10.4 Register Description for Touch Sensing

TSCR (Touch Sensing Interrupt Flag Register) : E2H

7	6	5	4	3	2	1	0
TSIFE-	-	-	-	-	-	-	TSIFR
R/W	-	-	-	-	-	-	R/W

Initial value : 00H

- TSIFE** Touch Sensor Interrupt Enable
 0 Touch Sensor INT Disable (Default)
 1 Touch Sensor INT Enable
- TSIFR** Touch Sensor Interrupt Flag
 0 Not ready for RAW data (Default)
 1 Ready for RAW data. Can read the RAW data.

TSTR (Touch Sensing Test Register) : E3H (TEST only)

7	6	5	4	3	2	1	0
TESTEN1	TESTEN0	NCEN1	NCEN0	-	-	-	-
R/W	R/W	R/W	R/W	-	-	-	-

Initial value : 00H

- TESTEN1** Touch Sensor digital test enable
 0 Test output disable (Default)
 1 Test output enable at P1[1:0]
- TESTEN0** Touch Sensor analog test enable
 0 Test output disable (Default)
 1 TEST_TSV signal output enable at P1[5]
- NCEN[1:0]** Select time of noise canceller
 11 Cancel under 25 ns
 10 Cancel under 20 ns
 01 Cancel under 15 ns
 00 Cancel under 10 ns (default)

RSD00 (Resistor Selection Data Register 0) : 2E40H

7	6	5	4	3	2	1	0
RSD7	RSD6	RSD5	RSD4	RSD3	RSD2	RSD1	RSD0
W	W	W	W	W	W	W	W
6K	5K	4.5K	4K	3.5K	3K	2.5K	2K

Initial value : xxH

The initial value for the all RSDxx registers (RSD00 ~ RSD27) is **unknowned**.
User must define the initial value for the all RSD registers except of zero value (00H).
 If user doesn't define all RSD registers but some RSD registers or zero value for RSD, the touch sensing operation will be unstable.

- RSD7** Resistor 7 of Touch Signal
 0 Resistor 7 Disable (Default)
 1 Resistor 7 Enable
- RSD6** Resistor 6 of Touch Signal
 0 Resistor 6 Disable (Default)

	1	Resistor 6 Enable
RSD5		Resistor 5 of Touch Signal
	0	Resistor 5 Disable (Default)
	1	Resistor 5 Enable
RSD4		Resistor 4 of Touch Signal
	0	Resistor 4 Disable (Default)
	1	Resistor 4 Enable
RSD3		Resistor 3 of Touch Signal
	0	Resistor 3 Disable (Default)
	1	Resistor 3 Enable
RSD2		Resistor 2 of Touch Signal
	0	Resistor 2 Disable (Default)
	1	Resistor 2 Enable
RSD1		Resistor 1 of Touch Signal
	0	Resistor 1 Disable (Default)
	1	Resistor 1 Enable
RSD0		Resistor 0 of Touch Signal
	0	Resistor 0 Disable (Default)
	1	Resistor 0 Enable

RSD01 (Resistor Selection Data Register 1) : 2E41H

RSD02 (Resistor Selection Data Register 2) : 2E42H

RSD03 (Resistor Selection Data Register 3) : 2E43H

RSD04 (Resistor Selection Data Register 4) : 2E44H

RSD05 (Resistor Selection Data Register 5) : 2E45H

RSD06 (Resistor Selection Data Register 6) : 2E46H

RSD07 (Resistor Selection Data Register 7) : 2E47H

RSD10 (Resistor Selection Data Register 10) : 2E48H

RSD11 (Resistor Selection Data Register 11) : 2E49H

RSD12 (Resistor Selection Data Register 12) : 2E4AH

RSD13 (Resistor Selection Data Register 13) : 2E4BH

RSD14 (Resistor Selection Data Register 14) : 2E4CH

RSD15 (Resistor Selection Data Register 15) : 2E4DH

RSD16 (Resistor Selection Data Register 16) : 2E4EH

RSD17 (Resistor Selection Data Register 17) : 2E4FH

RSD20 (Resistor Selection Data Register 20) : 2E50H

RSD21 (Resistor Selection Data Register 21) : 2E51H

RSD22 (Resistor Selection Data Register 22) : 2E52H

RSD23 (Resistor Selection Data Register 23) : 2E53H

RSD24 (Resistor Selection Data Register 24) : 2E54H

RSD25 (Resistor Selection Data Register 25) : 2E55H

RSD26 (Resistor Selection Data Register 26) : 2E56H

RSD27 (Resistor Selection Data Register 27) : 2E57H

TTMR (Touch-Timer Mode Register) : 2EC0H

7	6	5	4	3	2	1	0
TTCS	CCKS	0	0	0	0	TTCK1	TTCK0
RW	RW		-	-	-	RW	RW

Initial value : 00H

- TTCS** Touch Timer Clear and Start
 0 Touch-Timer Stop (Default)
 1 Touch-Timer Clear and Start
- CCKS** Counter CK Selection
 0 Counter CK = Touch Signal (Default)
 1 Counter CK = SCK
 * Remarks : with VCAL.6
- TTCK[1:0]** Reference Clock Selection
 00 SCK (Default)
 01 TSIG0
 10 -
 11 SCK or IRC16M
 * Remarks : with VCAL.6

TTDLL (Touch timer Data Low Register Low-Byte) : 2EC1H

7	6	5	4	3	2	1	0
TTDLL							
W	W	W	W	W	W	W	W

Initial value : -

TTDLH (Touch timer Data Low Register High-Byte) : 2EC2H

7	6	5	4	3	2	1	0
TTDLH							
W	W	W	W	W	W	W	W

Initial value : -

TTDHL (Touch timer Data High Register Low-Byte) : 2EC3H

7	6	5	4	3	2	1	0
TTDLL							
W	W	W	W	W	W	W	W

Initial value : -

TTDHH (Touch timer Data High Register High-Byte) : 2EC4H

7	6	5	4	3	2	1	0
TTDLH							
W	W	W	W	W	W	W	W

Initial value : -

KENR (Touch Key Enable Register) : 2EC5H

7	6	5	4	3	2	1	0
KEN7	KEN6	KEN5	KEN4	KEN3	KEN2	KEN1	KEN0
RW	RW	RW	RW	RW	RW	RW	RW

Initial value : 00H

KEN7	Key-7 Enable
0	Disable (Default)
1	Enable Touch Key by P0FT7/P2FT7/P3FT7
KEN6	Key-6 Enable
0	Disable (Default)
1	Enable Touch Key by P0FT6/P2FT6/P3FT6
KEN5	Key-5 Enable
0	Disable (Default)
1	Enable Touch Key by P0FT5/P2FT5/P3FT5
KEN4	Key-4 Enable
0	Disable (Default)
1	Enable Touch Key by P0FT4/P2FT4/P3FT4
KEN3	Key-3 Enable
0	Disable (Default)
1	Enable Touch Key by P0FT3/P2FT3/P3FT3
KEN2	Key-2 Enable
0	Disable (Default)
1	Enable Touch Key by P0FT2/P2FT2/P3FT2
KEN1	Key-1 Enable
0	Disable (Default)
1	Enable Touch Key by P0FT1/P2FT1/P3FT1
KEN0	Key-0 Enable
0	Disable (Default)
1	Enable Touch Key by P0FT0/P2FT0/P3FT0

KSMR (Touch Key Scan Mode Register) : 2EC6H

7	6	5	4	3	2	1	0
CBSH	CBS2	CBS1	CBS0	MSCAN	KSEN2	KSEN1	KSEN0
RW	RW	RW	RW	RW	RW	RW	RW

Initial value : 00H

CBSH	Internal Resistor Off
0	Resistor On(Default)
1	Resistor Off
CBS2	Comparator Bias2 Control
0	Disable (Default)
1	Enable
CBS1	Comparator Bias1 Control
0	Disable (Default)
1	Enable
CBS0	Comparator Bias0 Control

0 Disable (Default)
 1 Enable

MSCAN Manual Key Scan Enable
 0 Auto key Scan Mode (Default)
 1 Manual Key Scan Mode

KSEN2 Key-Scan Module 2 Enable
 0 Disable TSCOUNT2, Key-Scan Module 2 (Default)
 1 Enable TSCOUNT2, Key-Scan Module 2
 * Remarks : P3 (CS16 ~ 23)

KSEN1 Key-Scan Module 1 Enable
 0 Disable TSCOUNT1, Key-Scan Module1 (Default)
 1 Enable TSCOUNT1, Key-Scan Module1
 * Remarks : P2 (CS8 ~ 15)

KSEN0 Key-Scan Module 0 Enable
 0 Disable TSCOUNT0, Key-Scan Module0 (Default)
 1 Enable TSCOUNT0, Key-Scan Module0
 * Remarks : P0 (CS0 ~ 7)

FPCAL (Functional Power Calibration Register) : 2EC8H

7	6	5	4	3	2	1	0
-	-	PCALF1	PCALF0	BCALF3	BCALF2	BCALF1	BCALF0
		RW	RW	RW	RW	RW	RW

Initial value : 00H

PCALF[1:0] Touch Sensor CBS Power Control
 00 Maximum Voltage (Default)
 01
 10
 11 Minimum Voltage

BCALF[3:0] Touch Sensor Bias Control
 1000 Maximum Voltage
 1001
 1010
 ~
 1111
 0000 (Default)
 0001
 0010
 ~
 0111 Minimum Voltage

VCAL (Voltage Calibration Register) : 2EC9H

7	6	5	4	3	2	1	0
DPEN	CCKM	VCAL5	VCAL4	VCAL3	VCAL2	VCAL1	VCAL0
RW	RW	RW	RW	RW	RW	RW	RW

Initial value : 00H

DPEN Port Direct Pull-up Enable

0 Disable Direct Pull-up (Default)
 1 Enable Direct Pull-up
 * Remarks : Main Chip Only

CCKM Counter CK MUX
 0 CCK = SCK
 1 CCK = IRC16M
 * Remarks : with TTMR.6

VCAL[5:3] Touch Sensing Signal High Voltage Control
 111 0.88 * VREF
 110 0.84 * VREF
 101 0.80 * VREF
 100 0.75 * VREF
 011 0.70 * VREF
 010 0.65 * VREF
 001 0.60 * VREF
 000 0.55 * VREF (Default)

VCAL[2:0] Touch Sensing Signal Low Voltage Control
 111 0.84 * VREF
 110 0.80 * VREF
 101 0.75 * VREF
 100 0.70 * VREF
 011 0.65 * VREF
 010 0.60 * VREF
 001 0.55 * VREF
 000 0.40 * VREF (Default)

CCAL (Current Calibration Register for Frequency Control) : 2ECAH

7	6	5	4	3	2	1	0
CNV	CPV	CCAL5	CCAL4	CCAL3	CCAL2	CCAL1	CCAL0
R/W	R/W	R/W	R/W	R/W	R/W	R/W	R/W

Initial value : 00H

CNV N_Cal Fix
 0 Enable (Default)
 1 Disable

CPV P_Cal Fix
 0 Enable (Default)
 1 Disable

CCAL[5:4] Touch Sensing Signal Current Control (Freq.)
 11 Maximum Frequency
 10
 01
 00 Minimum Frequency (Default)

CCAL[3:0] Touch Sensing Signal Current Control(Freq.)
 1111 Maximum Frequency
 1110
 1101

~
 1000
 0000 (Default)
 0001
 0010
 ~
 0111 Minum Frequency

TSCTL0 (Touch Sensor Control Register 0) : 2ECBH

7	6	5	4	3	2	1	0
TSBS	TSEN	SPUEN	FBIASEN	NFEN	SIN2	0	SIN0
R/W	R/W	R/W	R/W	R/W	R/W		R/W

Initial value : 00H

TSBS Touch Sensor Bias Set
 0 Touch Sensor Bias OFF(Default)
 1 Touch Sensor Bias ON

TSEN Touch Sensing Enable
 0 Touch Sensing Disable (Default)
 1 Touch Sensing Enable

SPUEN Signal Pull-up Enable (Internal High Drive Control)
 0 Touch Signal Pull-up Disable (Default)
 1 Touch Signal Pull-up Enable

FBIASEN Functional BIAS Enable
 0 Config. Reg. Enable (Default)
 1 FPCAL Ref. Enable

NFEN Noise Filter Enable
 0 Noiste Filter Disable (Default)
 1 Noise Filter Enable

SIN2 Touch Sensing Port Driver2 Control
 0 Driver2 Disable (Default)
 1 Driver2 Enable

SIN0 Touch Sensing Port Driver0 Control
 0 Driver0 Disable (Default)
 1 Driver0 Enable

TSCTL1 (Touch Sensor Control Register 1) : 2ECCH

7	6	5	4	3	2	1	0
DS1	DS0	CIEN	RIEN	LSDIS	TBIAS2	TBIAS1	TBIAS0
R/W	R/W	R/W	R/W	R/W	R/W	R/W	R/W

Initial value : 00H

DS1[1:0] Delay Selection
 00 Normal (Default)
 01 Fast
 10 Slow
 11 Forbidden

CIEN	NF Capacitor Enable
0	NF Cap. Input Disable (Default)
1	NF Cap. Input Enable
RIEN	NF Resistor Enable
0	NF Resistor. Input Disable (Default)
1	NF Resistor Input Enable
LSDIS	Low Sensing Disable
0	Low Sensing Enable (Default)
1	Low Sensing Disable
TBIAS[2:0]	Touch Sensor Bias Test (* Remarks : P15)
000	Floating (Default)
001	Touch Bias Output
010	Touch Sensor Reference Power Output
011	Forbidden
100	Floating
101	Touch Signal Low-Voltage Output
110	Touch Signal High-Voltage Output
1111	Forbidden

P0FT (P0 Port Touch Function Register) : 2ECDH

7	6	5	4	3	2	1	0
P0FT7	P0FT6	P0FT5	P0FT4	P0FT3	P0FT2	P0FT1	P0FT0
RW	RW	RW	RW	RW	RW	RW	RW

Initial value : 00H

P0FT7	P07 Function Selection
0	P07 Port-Function Selection (Default)
1	P07 Touch-Key Function Selection (= CS7)
P0FT 6	P06 Function Selection
0	P06 Port-Function Selection (Default)
1	P06 Touch-Key Function Selection (= CS6)
P0FT 5	P05 Function Selection
0	P05 Port-Function Selection (Default)
1	P05 Touch-Key Function Selection (= CS5)
P0FT 4	P04 Function Selection
0	P04 Port-Function Selection (Default)
1	P04 Touch-Key Function Selection (= CS4)
P0FT 3	P03 Function Selection
0	P03 Port-Function Selection (Default)
1	P03 Touch-Key Function Selection (= CS3)
P0FT 2	P02 Function Selection
0	P02 Port-Function Selection (Default)
1	P02 Touch-Key Function Selection (= CS2)
P0FT 1	P01 Function Selection
0	P01 Port-Function Selection (Default)
1	P01 Touch-Key Function Selection (= CS1)
P0FT 0	P00 Function Selection

- 0 P00 Port-Function Selection (Default)
- 1 P00 Touch-Key Function Selection (= CS0)

P2FT (P2 Port Touch Function Register) : 2ECEH

7	6	5	4	3	2	1	0
P2FT7	P2FT6	P2FT5	P2FT4	P2FT3	P2FT2	P2FT1	P2FT0
R/W	R/W	R/W	R/W	R/W	R/W	R/W	R/W

Initial value : 00H

- P2FT7** P27 Function Selection
 - 0 P27 Port-Function Selection (Default)
 - 1 P27 Touch-Key Function Selection (= CS15)
- P2FT 6** P26 Function Selection
 - 0 P26 Port-Function Selection (Default)
 - 1 P26 Touch-Key Function Selection (= CS14)
- P2FT 5** P25 Function Selection
 - 0 P25 Port-Function Selection (Default)
 - 1 P25 Touch-Key Function Selection (= CS13)
- P2FT 4** P24 Function Selection
 - 0 P24 Port-Function Selection (Default)
 - 1 P24 Touch-Key Function Selection (= CS12)
- P2FT 3** P23 Function Selection
 - 0 P23 Port-Function Selection (Default)
 - 1 P23 Touch-Key Function Selection (= CS11)
- P2FT 2** P22 Function Selection
 - 0 P22 Port-Function Selection (Default)
 - 1 P22 Touch-Key Function Selection (= CS10)
- P2FT 1** P21 Function Selection
 - 0 P21 Port-Function Selection (Default)
 - 1 P21 Touch-Key Function Selection (= CS9)
- P2FT 0** P20 Function Selection
 - 0 P20 Port-Function Selection (Default)
 - 1 P20 Touch-Key Function Selection (= CS8)

P3FT (P3 Port Touch Function Register) : 2ECFH

7	6	5	4	3	2	1	0
P3FT7	P3FT6	P3FT5	P3FT4	P3FT3	P3FT2	P3FT1	P3FT0
R/W	R/W	R/W	R/W	R/W	R/W	R/W	R/W

Initial value : 00H

- P3FT7** P37 Function Selection
 - 0 P37 Port-Function Selection (Default)
 - 1 P37 Touch-Key Function Selection (= CS23)
- P3FT 6** P36 Function Selection
 - 0 P36 Port-Function Selection (Default)
 - 1 P36 Touch-Key Function Selection (= CS22)
- P3FT 5** P35 Function Selection

	0	P35 Port-Function Selection (Default)
	1	P35 Touch-Key Function Selection (= CS21)
P3FT 4		P34 Function Selection
	0	P34 Port-Function Selection (Default)
	1	P34 Touch-Key Function Selection (= CS20)
P3FT 3		P33 Function Selection
	0	P33 Port-Function Selection (Default)
	1	P33 Touch-Key Function Selection (= CS19)
P3FT 2		P32 Function Selection
	0	P32 Port-Function Selection (Default)
	1	P32 Touch-Key Function Selection (= CS18)
P3FT 1		P31 Function Selection
	0	P31 Port-Function Selection (Default)
	1	P31 Touch-Key Function Selection (= CS17)
P3FT 0		P30 Function Selection
	0	P30 Port-Function Selection (Default)
	1	P30 Touch-Key Function Selection (= CS16)

11.10.5 User Programming Procedure

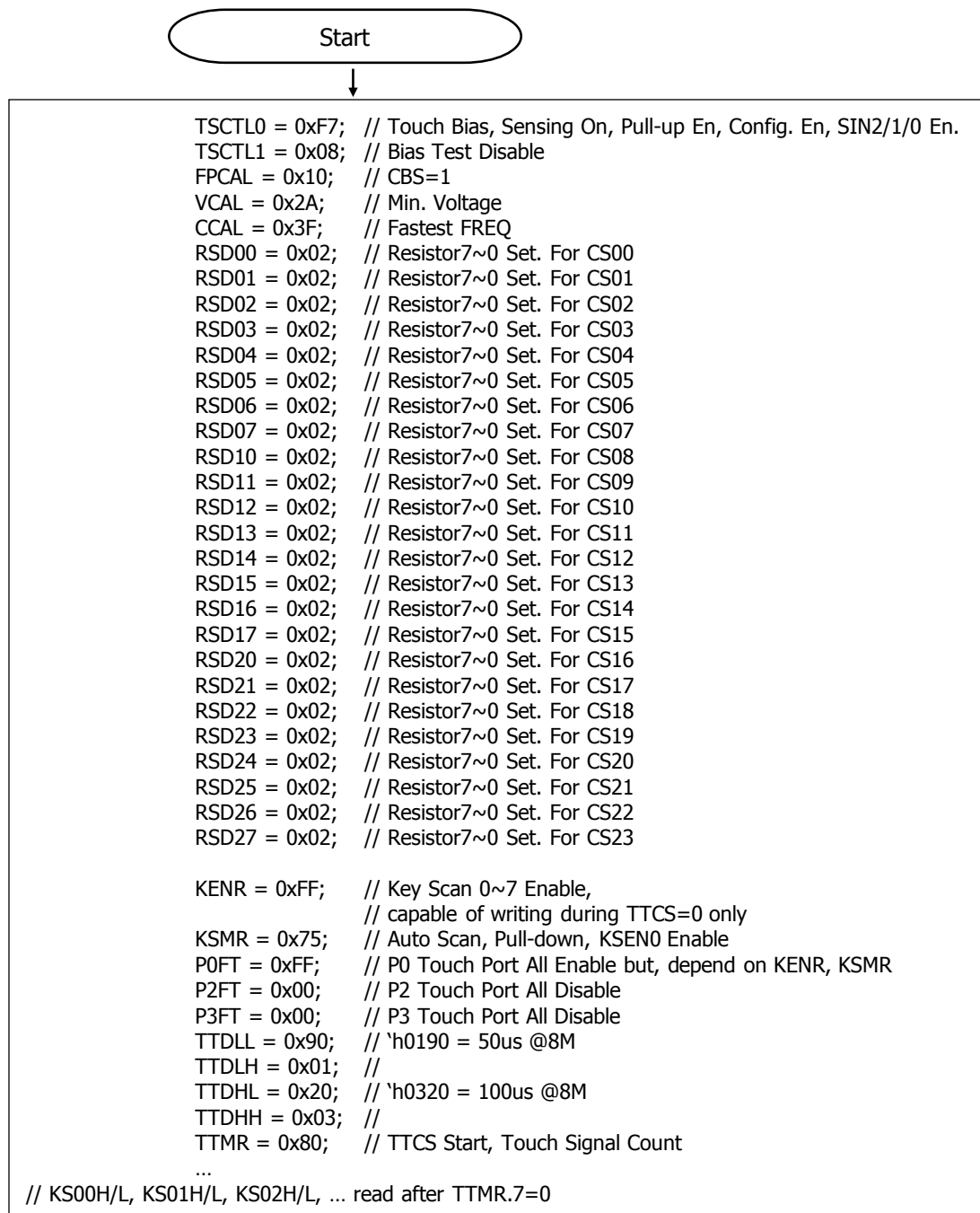

Figure 11-37 User Programming Procedure

12. Power Down Operation

12.1 Overview

The MC96FT242 has three power-down modes to minimize the power consumption of the device. In power down mode, power consumption is reduced considerably. The device provides three kinds of power saving functions, IDLE, STOP1 and STOP2 mode. In three modes, program is stopped.

12.2 Peripheral Operation in IDLE/STOP Mode

Table 12-1 Peripheral Operation during Power Down Mode.

Peripheral	IDLE Mode	STOP1 Mode	STOP2 Mode
CPU	ALL CPU Operation are Disable	ALL CPU Operation are Disable	ALL CPU Operation are Disable
RAM	Retain	Retain	Retain
Basic Interval Timer	Operates Continuously	Operates Continuously	Stop
Watch Dog Timer	Operates Continuously	Operates Continuously	Stop
Timer	Operates Continuously	Halted	Halted
I ² C	Operates Continuously	Stop	Stop
Internal OSC (16MHz)	Oscillation	Stop	Stop
Internal RC-OSC (1MHz)	Oscillation	Oscillation	Stop
I/O Port	Retain	Retain	Retain
Control Register	Retain	Retain	Retain
Address Data Bus	Retain	Retain	Retain
Release Method	By RESET, all Interrupts	By RESET, PCI, I ² C (slave mode), WDT, BIT, USART	By RESET, PCI, I ² C (slave mode), USART

12.3 IDLE mode

The power control register is set to '01h' to enter the IDLE Mode. In this mode, the internal oscillation circuits remain active. Oscillation continues and peripherals are operated normally but CPU stops. It is released by reset or interrupt. To be released by interrupt, interrupt should be enabled before IDLE mode. If using reset, because the device becomes initialized state, the registers have reset value.

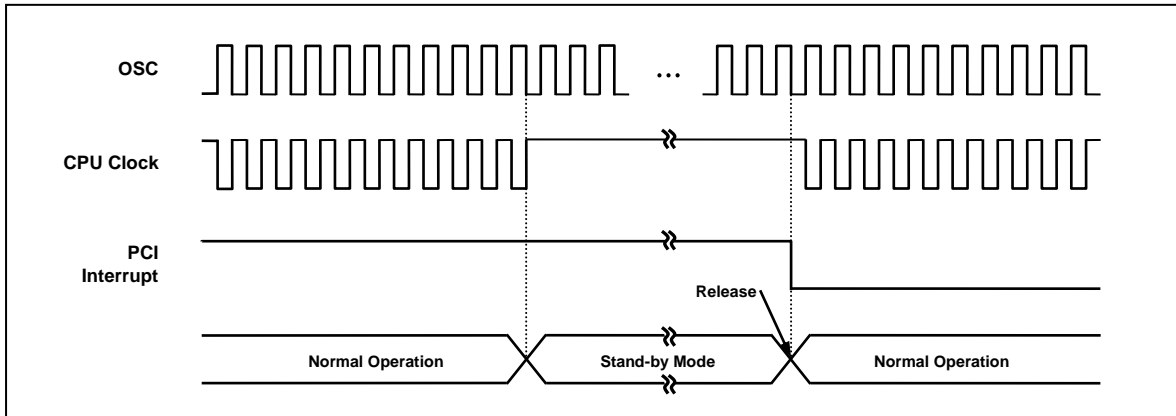

Figure 12-1 IDLE Mode Release Timing by PCI Interrupt

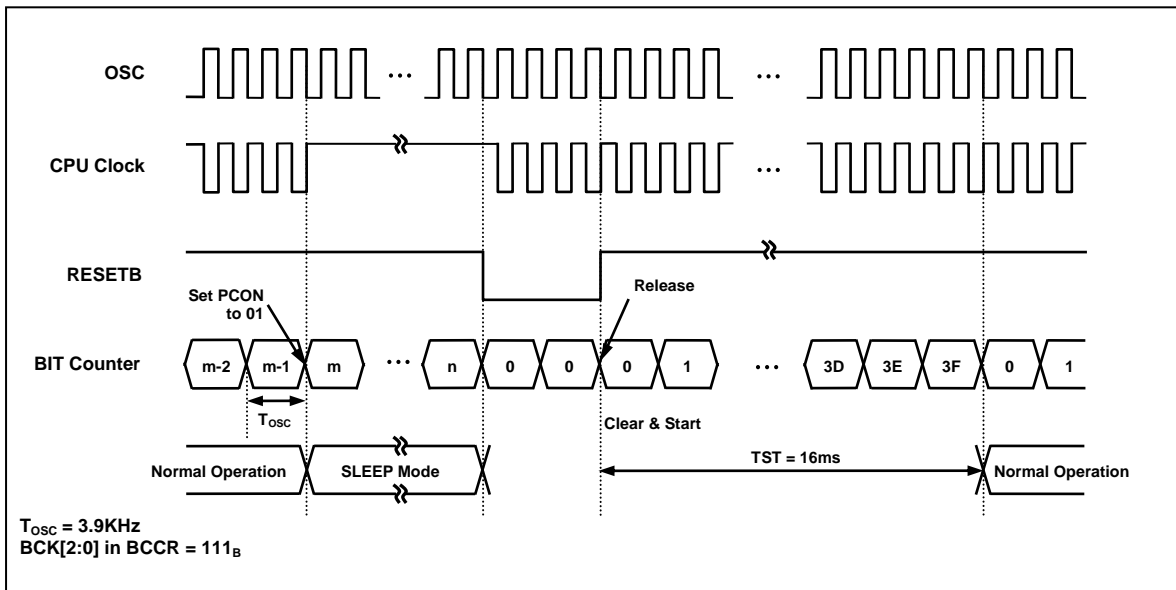

Figure 12-2 IDLE Mode Release Timing by RESETB

(Ex) MOV PCON, #0000_0001b ; setting of IDLE mode : set the bit of STOP and IDLE Control register (PCON)

12.4 STOP mode

The power control register is set to '03h' to enter the STOP Mode. In the stop mode, the main oscillator, system clock, and peripheral clock are stopped, but watch dog timer continue to operate. With the clock frozen, all functions are stopped, but the on-chip RAM and control registers are held.

The source for exit from STOP mode is hardware reset and interrupts. The reset re-defines all the control registers.

When exit from STOP mode, enough oscillation stabilization time is required to normal operation. Figure 12-3 shows the timing diagram. When released from STOP mode, the basic interval timer is activated on wake-up. Therefore, before STOP instruction, user must be set its relevant prescaler divide ratio to have long enough time (more than 1msec). this guarantees that oscillator has started and stabilized.

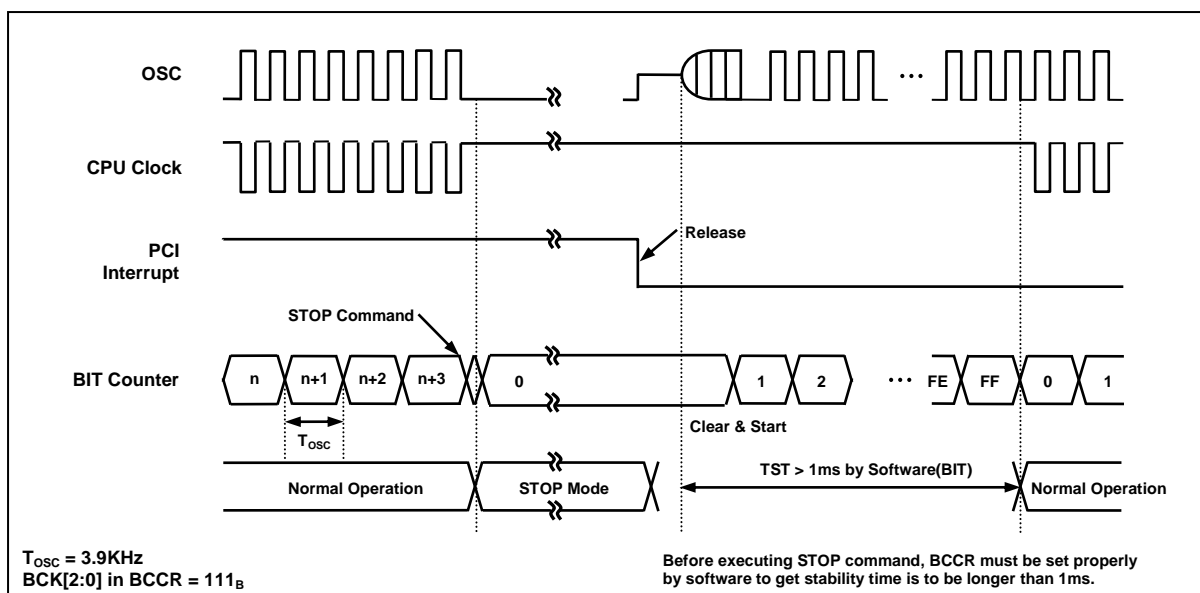

Figure 12-3 STOP Mode Release Timing by PCI Interrupt

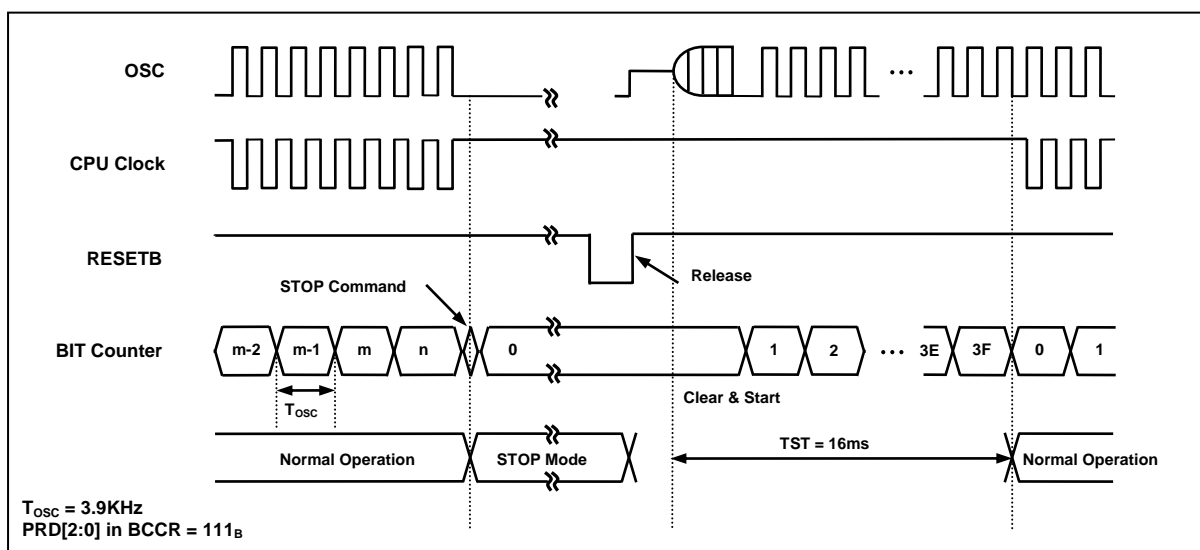

Figure 12-4 STOP Mode Release Timing by RESETB

12.5 Release Operation of STOP1, 2 Mode

After STOP1, 2 mode is released, the operation begins according to content of related interrupt register just before STOP1, 2 mode start (Figure 12-5). Interrupt Enable Flag of All (EA) of IE should be set to `1`. Released by only interrupt which each interrupt enable flag = `1`, and jump to the relevant interrupt service routine.

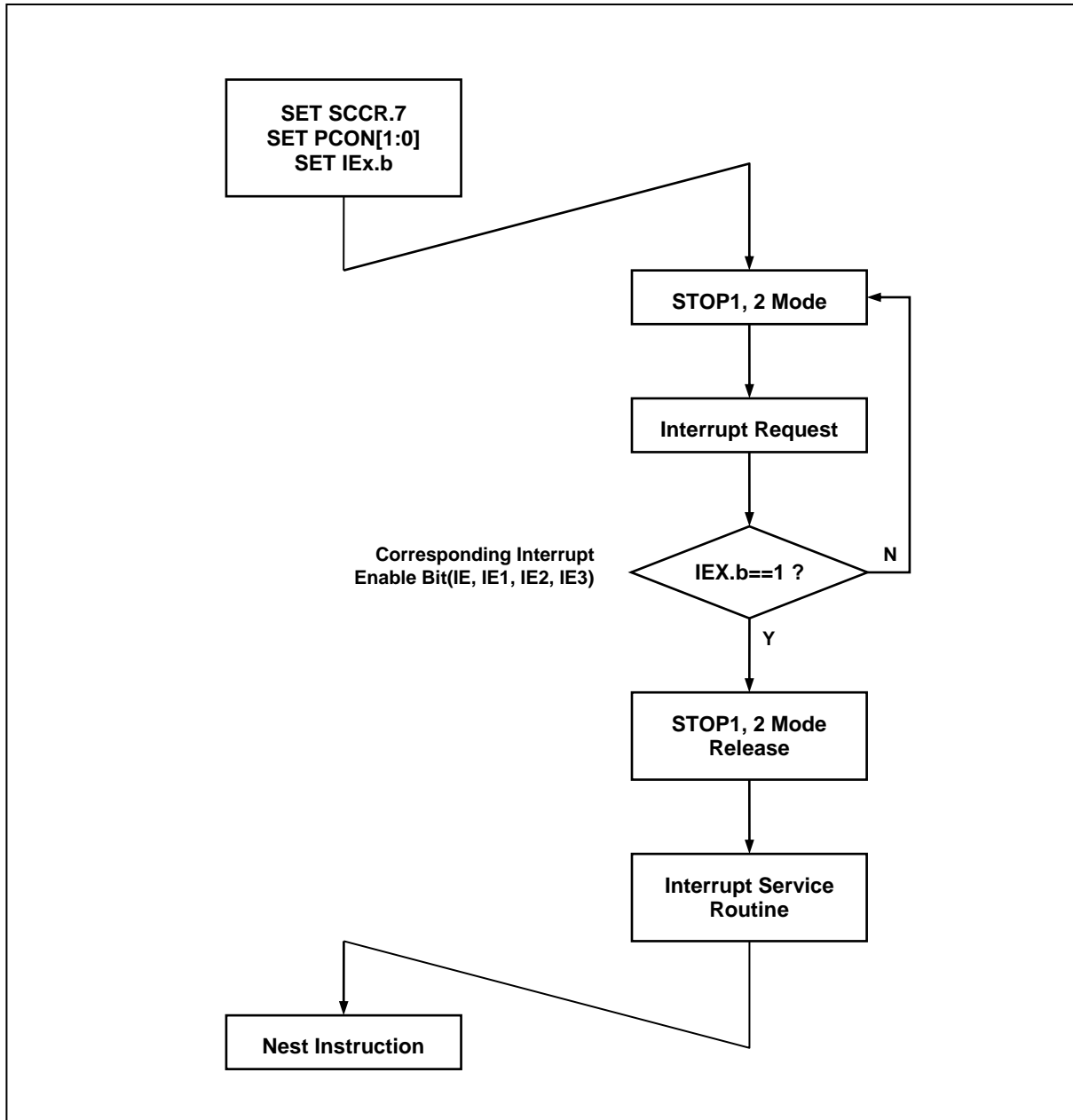

Figure 12-5 STOP1, 2 Mode Release Flow

12.5.1 Register Map

Table 12-2 Register Map

Name	Address	Dir	Default	Description
PCON	87H	R/W	00H	Power Control Register

12.5.2 Power Down Operation Register Description

The Power Down Operation Register consists of the Power Control Register (PCON).

12.5.3 Register Description for Power Down Operation

PCON (Power Control Register) : 87H

7	6	5	4	3	2	1	0
bit7	bit6	bit5	bit4	bit3	bit2	bit1	bit0
RW	RW	RW	RW	RW	RW	RW	RW

Initial value : 00H

IDLE Mode

01H IDLE mode enable

STOP1, 2 Mode

03H STOP1, 2 mode enable

Note)

1. To enter IDLE mode, PCON must be set to '01H'.
2. To STOP1,2 mode, PCON must be set to '03H'.
(In STOP1,2 mode, PCON register is cleared automatically by interrupt or reset)
3. When PCON is set to '03H', if SCCR[7] is set to '1', it enters the STOP1 mode. If SCCR[7] is cleared to '0', it enters the STOP2 mode
4. The different thing in STOP 1,2 is only clock operation of internal 125kHz-OSC during STOP mode operating.

13. RESET

13.1 Overview

The MC96FT242 has reset by external RESETB pin. The following is the hardware setting value.

Table 13-1 Reset state

On Chip Hardware	Initial Value
Program Counter (PC)	0000h
Accumulator	00h
Stack Pointer (SP)	07h
Peripheral Clock	On
Control Register	Peripheral Registers refer
Brown-Out Detector	Enable

13.2 Reset Source

The MC96FT242 has five types of reset generation procedures. The following is the reset sources.

- External RESETB
- Power ON RESET (POR)
- WDT Overflow Reset (In the case of WDTEN = `1`)
- BOD Reset (In the case of BODEN = `1`)
- OCD Reset

13.3 Block Diagram

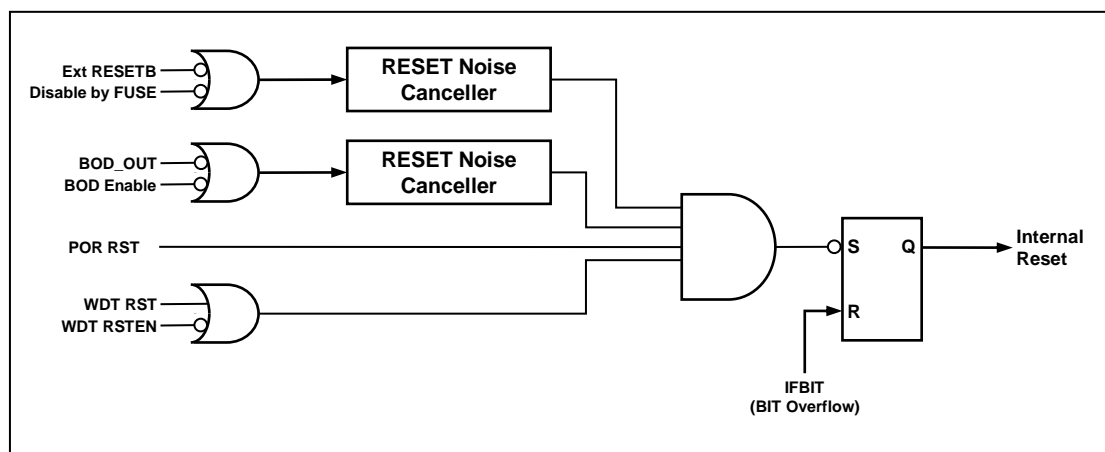

Figure 13-1 RESET Block Diagram

13.4 RESET Noise Canceller

The Figure 13-2 is the Noise canceller diagram for Noise cancel of RESET. It has the Noise cancel value of about 7us (@V_{DD}=5V) to the low input of System Reset.

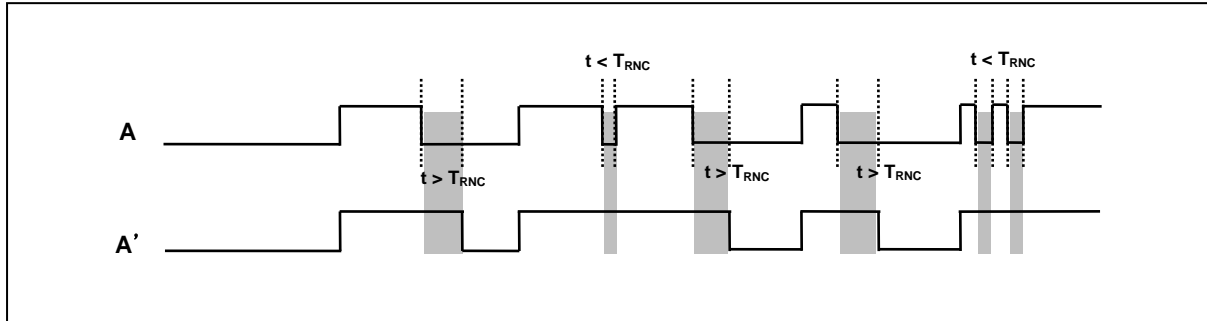

Figure 13-2 Reset noise canceller time diagram

13.5 Power ON RESET

When rising device power, the POR (Power ON Reset) have a function to reset the device. If using POR, it executes the device RESET function instead of the RESET IC or the RESET circuits. And External RESET PIN is able to use as Normal input pin.

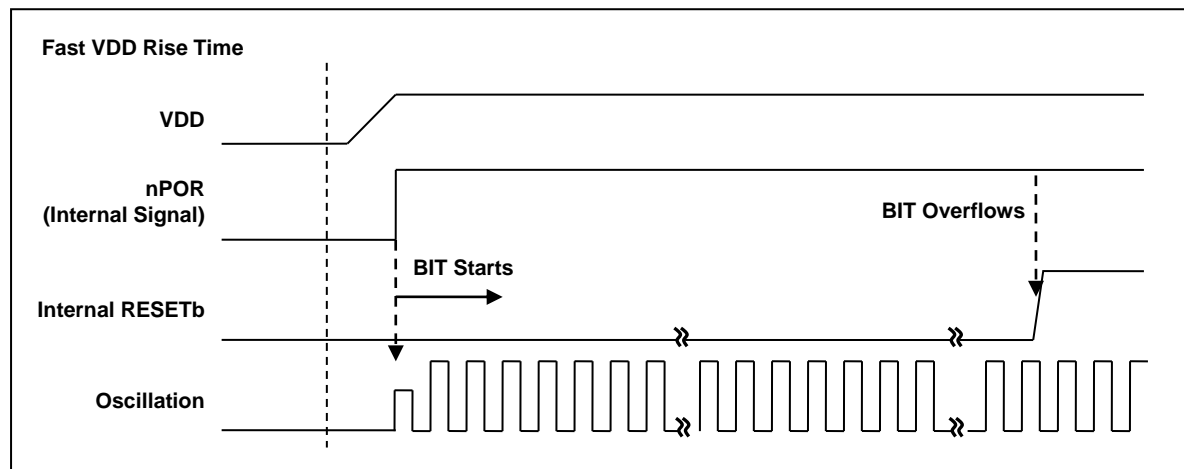

Figure 13-3 Fast VDD rising time

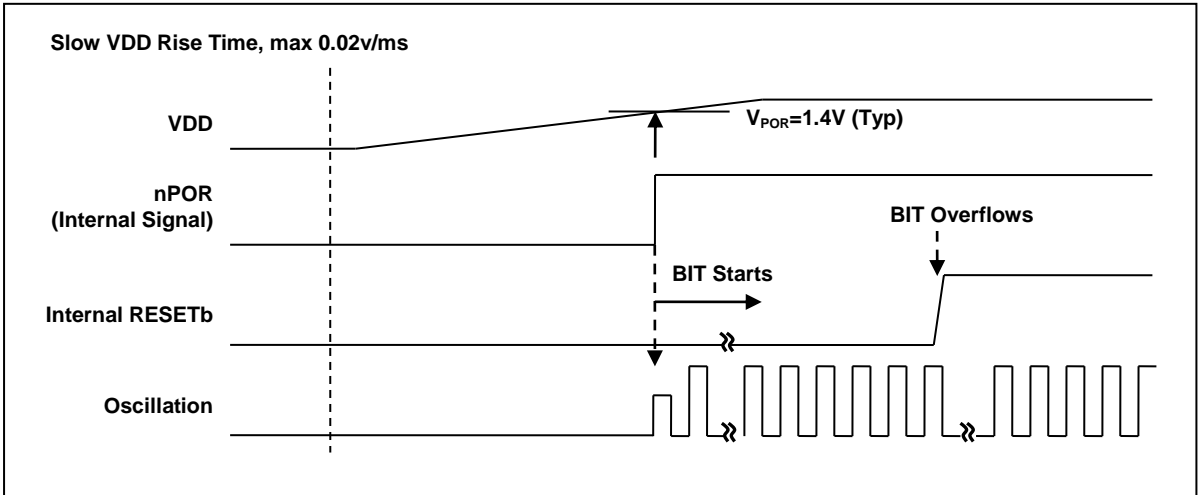

Figure 13-4 Internal RESET Release Timing On Power-Up

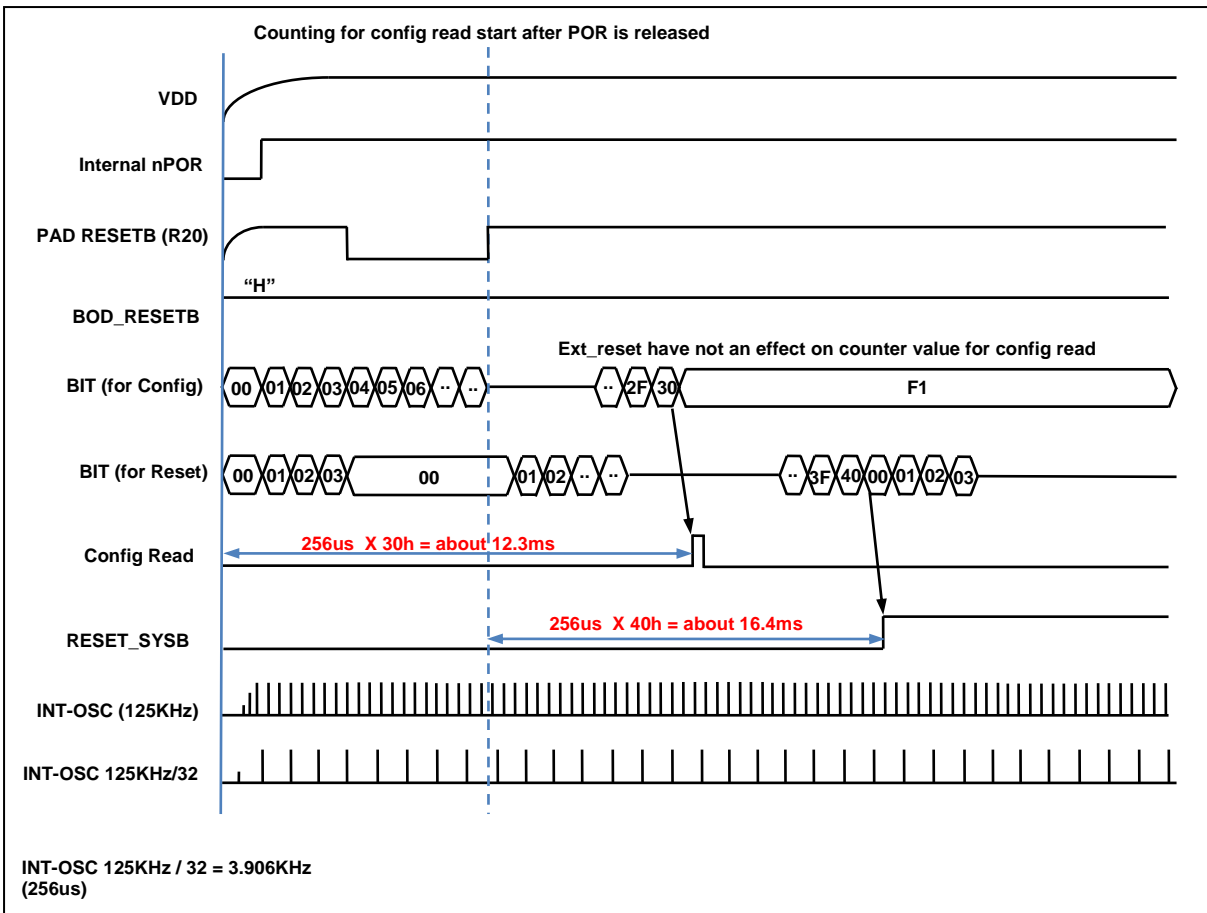

Figure 13-5 Configuration timing when Power-on

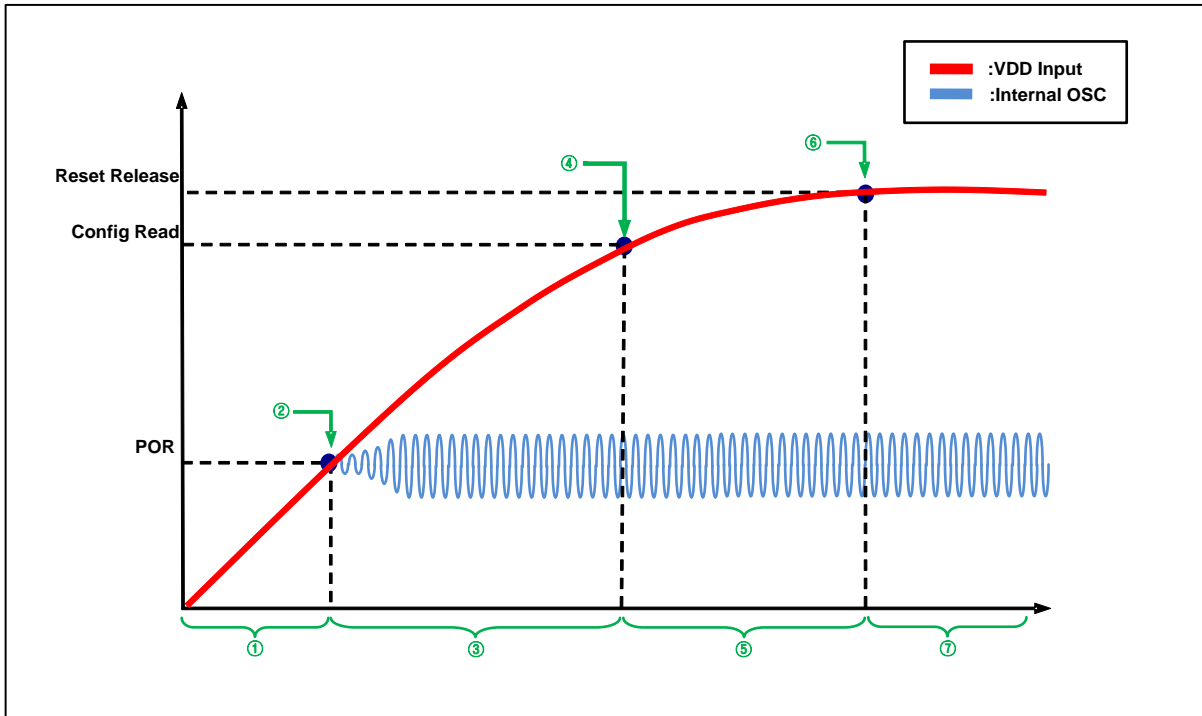

Figure 13-6 Boot Process Wave Form

Table 13-2 Boot Process Description

Process	Description	Remarks
①	-No Operation	
②	-1st POR level Detection -Internal OSC (125KHz) ON	-about 1.4V ~ 1.5V
③	- (INT-OSC125KHz/32)×30h Delay section (=12ms) -VDD input voltage must rise over than flash operating voltage for Config read	-Slew Rate \geq 0.025V/ms
④	- Config read point	-about 1.5V ~ 1.6V -Config Value is determined by Writing Option
⑤	- Rising section to Reset Release Level	-16ms point after POR or Ext_reset release
⑥	- Reset Release section (BIT overflow) i) after16ms, after External Reset Release (External reset) ii) 16ms point after POR (POR only)	- BIT is used for Peripheral stability
⑦	-Normal operation	

13.6 External RESETB Input

The External RESETB is the input to a Schmitt trigger. A reset is accomplished by holding the reset pin low for at least 7us over, within the operating voltage range and oscillation stable, it is applied, and the internal state is initialized. After reset state becomes '1', it needs the stabilization time with 16ms and after the stable state, the internal RESET becomes '1'. The Reset process step needs 5 oscillator clocks. And the program execution starts at the vector address stored at address 0000H.

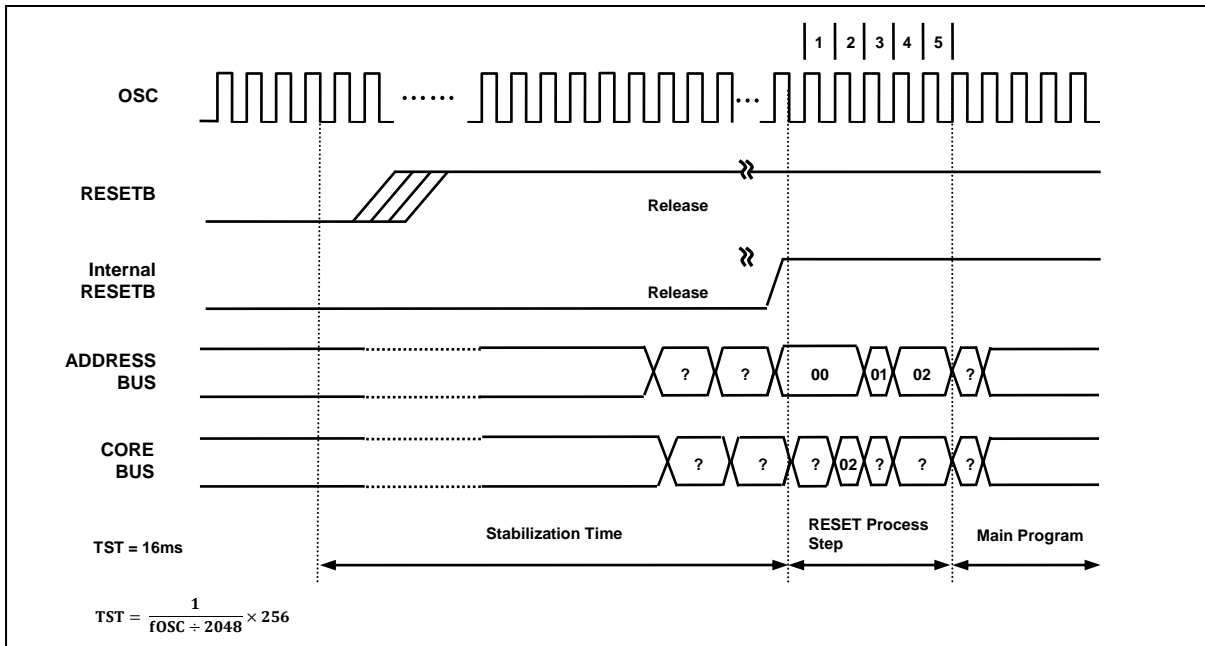

Figure 13-7 Timing Diagram after RESET

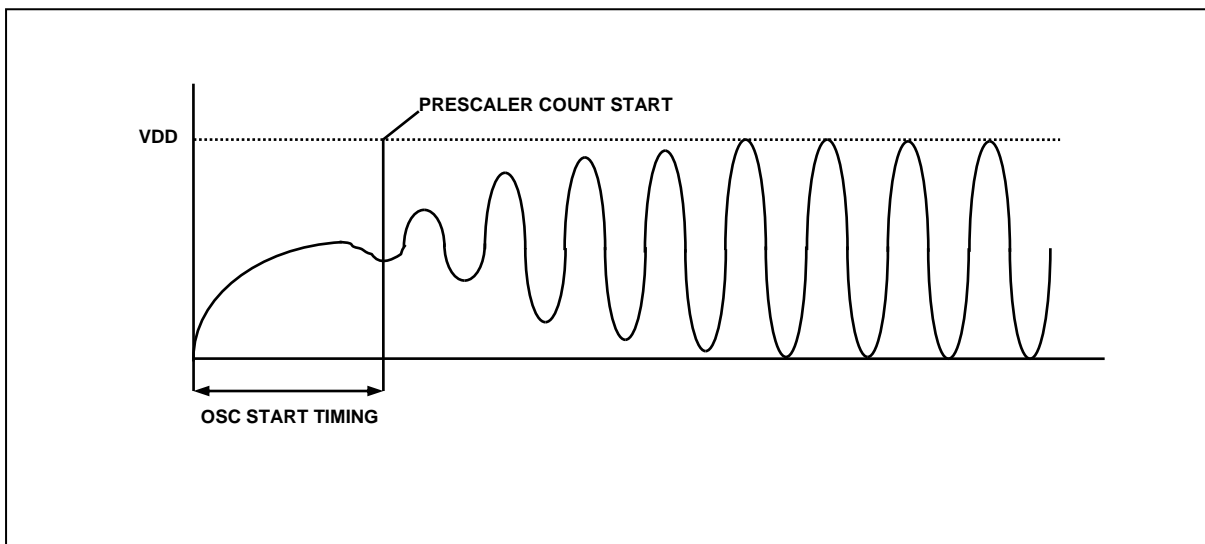

Figure 13-8 Oscillator generating waveform example

Note) as shown Figure 13-8, the stable generating time is not included in the start-up time.

13.7 Brown Out Detector Processor

The MC96FT242 has an On-chip Brown-out detection circuit for monitoring the VDD level during operation by comparing it to a fixed trigger level. The trigger level for the BOD can be selected by BODLS[1:0] bit to be 1.6V, 2.5V, 3.6V or 4.2V. In the STOP mode, this will contribute significantly to the total current consumption. So to minimize the current consumption, the BODEN bit is set to off by software.

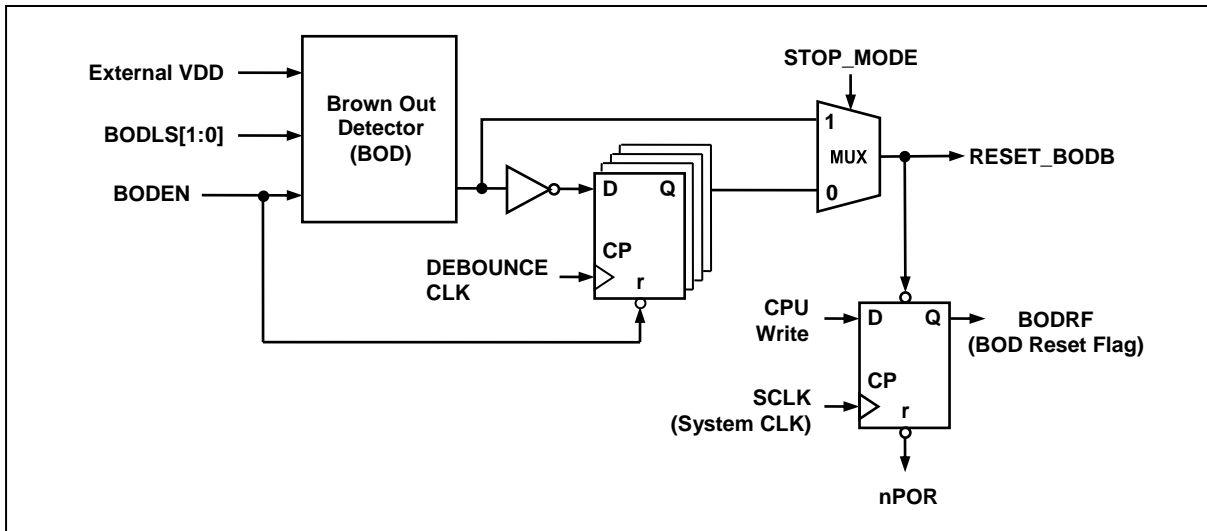

Figure 13-9 Block Diagram of BOD

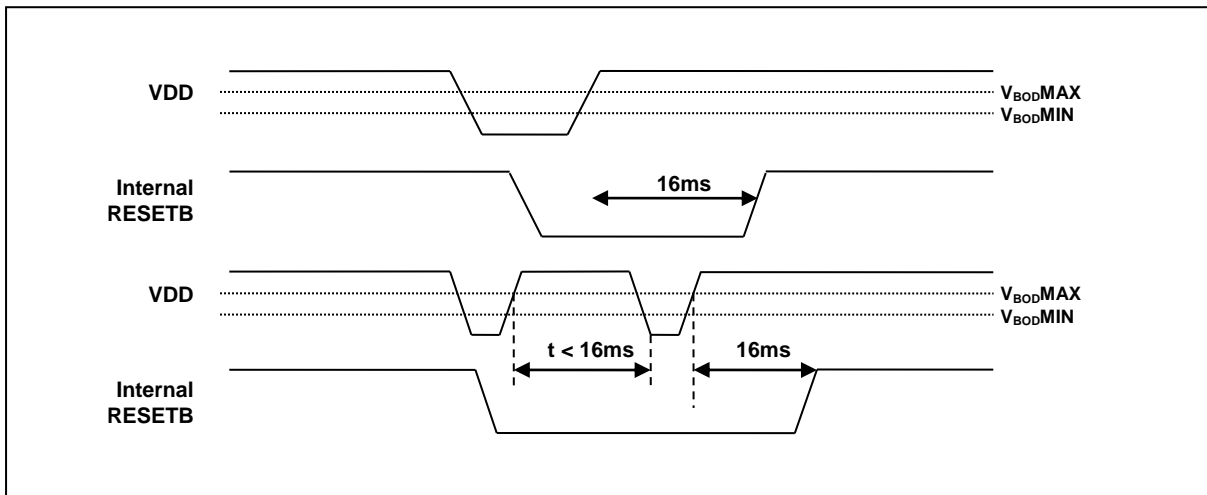

Figure 13-10 Internal Reset at the Power Fail Situation

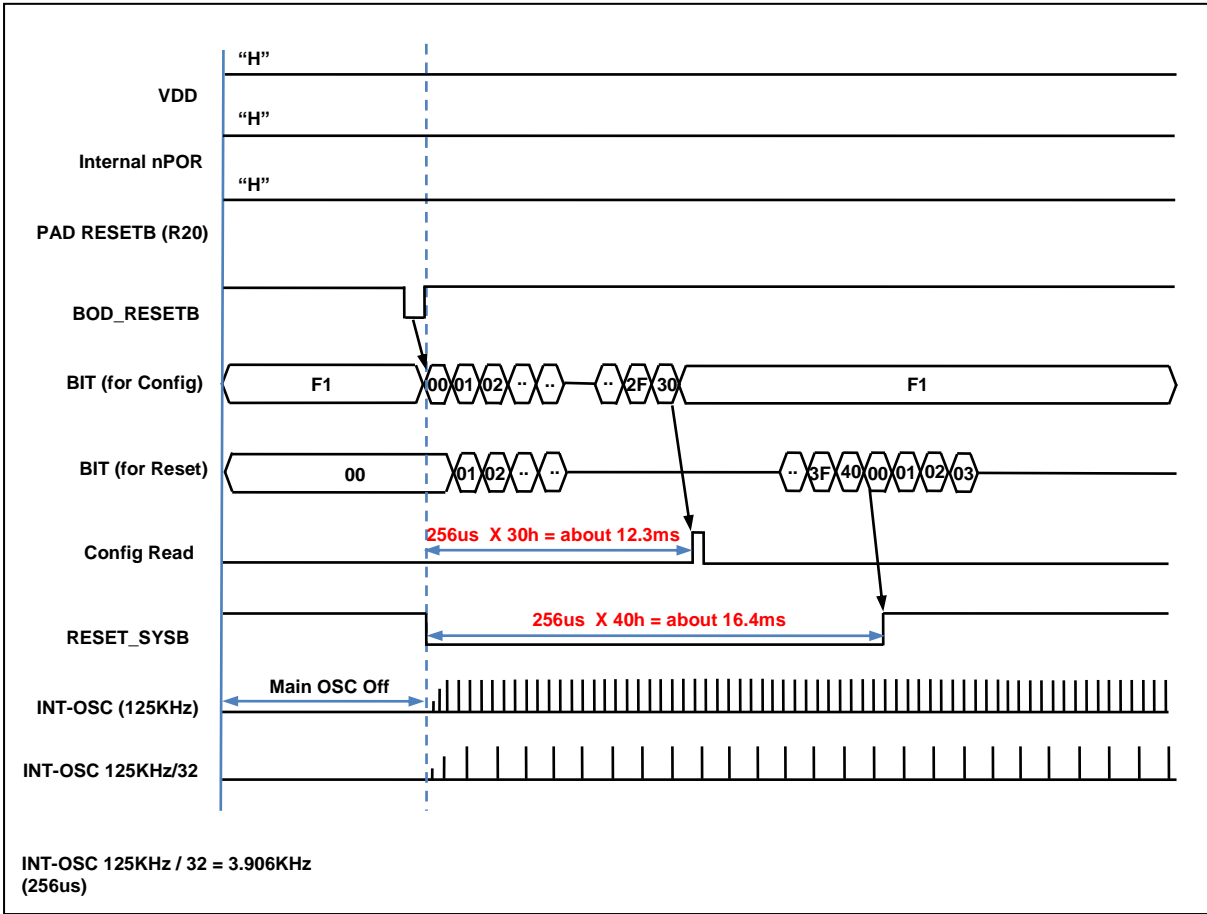

Figure 13-11 Configuration Timing when BOD Reset

13.7.1 Register Map

Table 13-3 Register Map

Name	Address	Dir	Default	Description
BODR	86H	R/W	81H	BOD Control Register
LVDR	8FH	R/W	01H	LVD Control Register

13.7.2 Reset Operation Register Description

Reset control Register consists of the BOD Control Register (BODR) and LVD Control Register (LVDR).

13.7.3 Register Description for Reset Operation

BODR (BOD Control Register) : 86H

7	6	5	4	3	2	1	0
PORF	EXTRF	WDTRF	OCDRF	BODRF	BODLS[1]	BODLS[0]	BODEN
R/W	R/W	R/W	R/W	R/W	R/W	R/W	R/W

Initial value : 81H

PORF	Power-On Reset flag bit. The bit is reset by writing '0' to this bit.		
0	No detection		
1	Detection		
EXTRF	External Reset flag bit. The bit is reset by writing '0' to this bit or by Power ON reset.		
0	No detection		
1	Detection		
WDTRF	Watch Dog Reset flag bit. The bit is reset by writing '0' to this bit or by Power ON reset.		
0	No detection		
1	Detection		
OCDRF	On-Chip Debug Reset flag bit. The bit is reset by writing '0' to this bit or by Power ON reset.		
0	No detection		
1	Detection		
BODRF	Brown-Out Reset flag bit. The bit is reset by writing '0' to this bit or by Power ON reset.		
0	No detection		
1	Detection		
BODLS[1:0]	BOD level Voltage		
	BODLS1	BODLS0	Description
	0	0	1.6V
	0	1	2.5V
	1	0	3.6V
	1	1	4.2V
BODEN	BOD operation		
0	BOD disable		
1	BOD enable		

LVDR (LVD Control Register) : 8FH

7	6	5	4	3	2	1	0
-	-	-	-	-	-	LVDRF	LVDEN
-	-	-	-	-	-	R/W	R/W

Initial value : 01H

LVDRF	LVD Reset flag bit. The bit is reset by writing '0' to this bit or by Power ON reset.		
0	No detection		
1	Detection		
LVDEN	LVD operation		
0	LVD disable		
1	LVD enable		

14. On-chip Debug System

14.1 Overview

14.1.1 Description

On-chip debug System (OCD) of MC96FT242 can be used for programming the non-volatile memories and on-chip debugging. Detailed descriptions for programming via the OCD interface can be found in the following chapter.

Figure 14-1 shows a block diagram of the OCD interface and the On-chip Debug system.

14.1.2 Feature

- Two-wire external interface: 1-wire serial clock input, 1-wire bi-directional serial data bus
- Debugger Access to:
 - All Internal Peripheral Units
 - Internal data RAM
 - Program Counter
 - Flash Memory
- Extensive On-chip Debug Support for Break Conditions, Including
 - Break Instruction
 - Single Step Break
 - Program Memory Break Points on Single Address
 - Programming of Flash, Fuses, and Lock Bits through the two-wire Interface
 - On-chip Debugging Supported by Dr.Choice[®]
- Operating frequency
 - Supports the maximum frequency of the target MCU

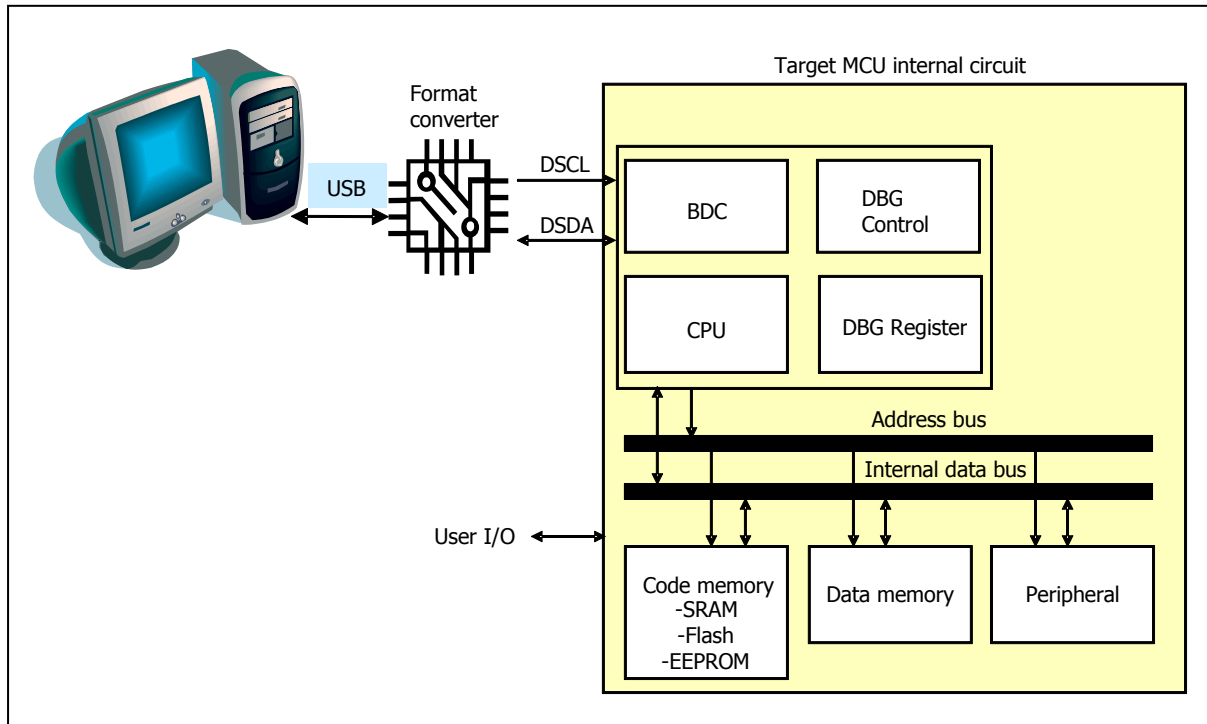

Figure 14-1 Block Diagram of On-chip Debug System

14.2 Two-pin External Interface

14.2.1 Basic Transmission Packet

- 10-bit packet transmission using two-pin interface.
- 1-packet consists of 8-bit data, 1-bit parity and 1-bit acknowledge.
- Parity is even of '1' for 8-bit data in transmitter.
- Receiver generates acknowledge bit as '0' when transmission for 8-bit data and its parity has no error.
- When transmitter has no acknowledge (Acknowledge bit is '1' at tenth clock), error process is executed in transmitter.
- When acknowledge error is generated, host PC makes stop condition and transmits command which has error again.
- Background debugger command is composed of a bundle of packet.
- Star condition and stop condition notify the start and the stop of background debugger command respectively.

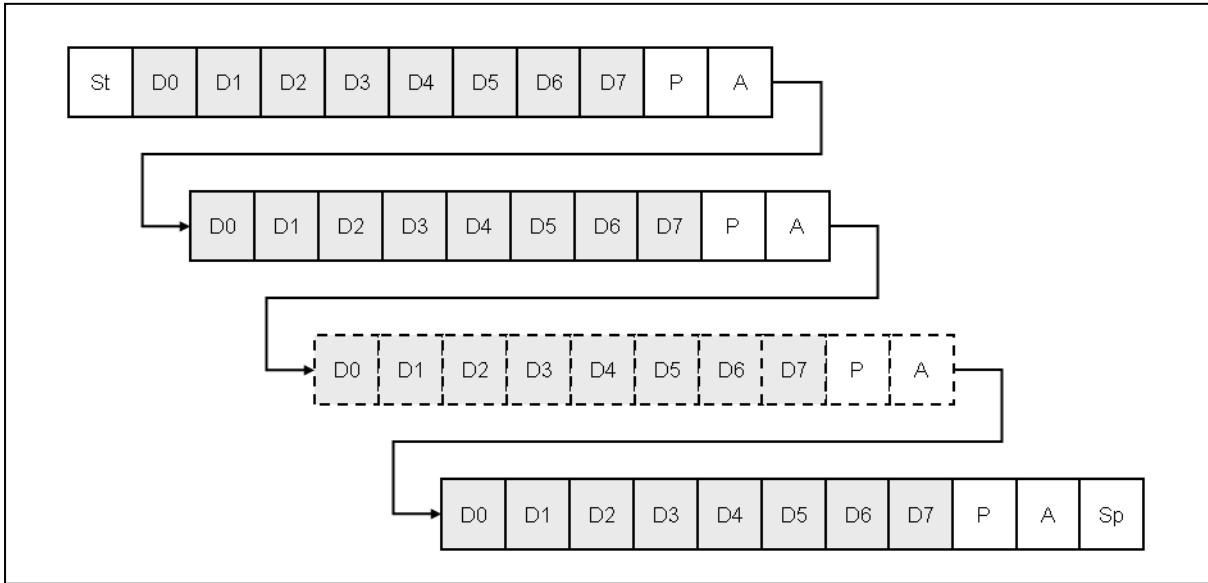

Figure 14-2 10-bit Transmission Packet

14.2.2 Packet Transmission Timing

14.2.2.1 Data transfer

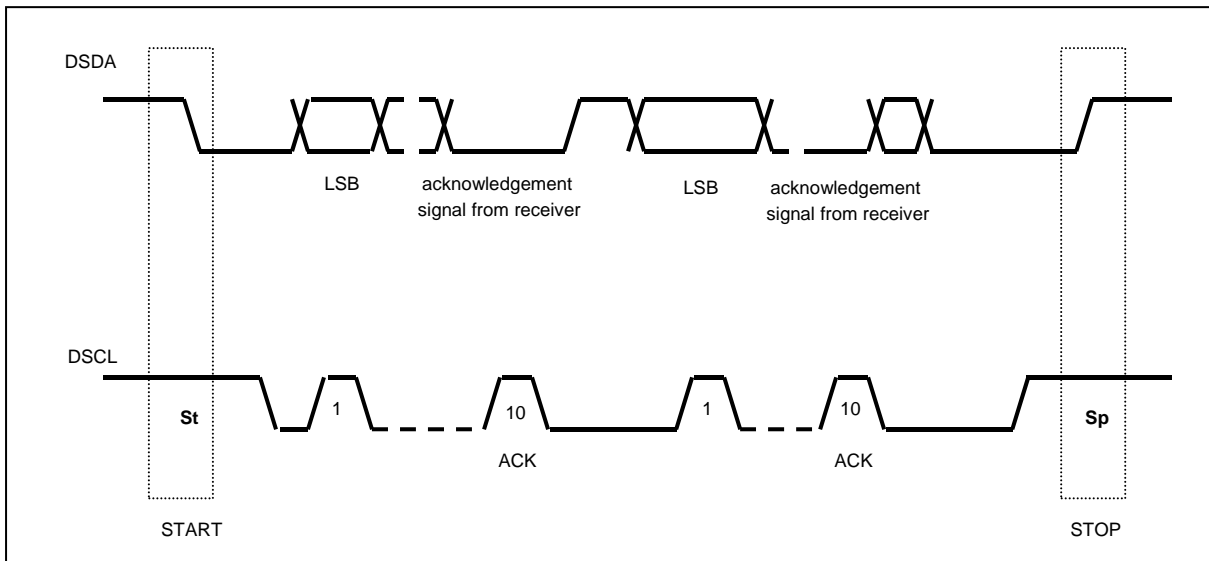

Figure 14-3 Data Transfer on the Twin Bus

14.2.2.2 Bit transfer

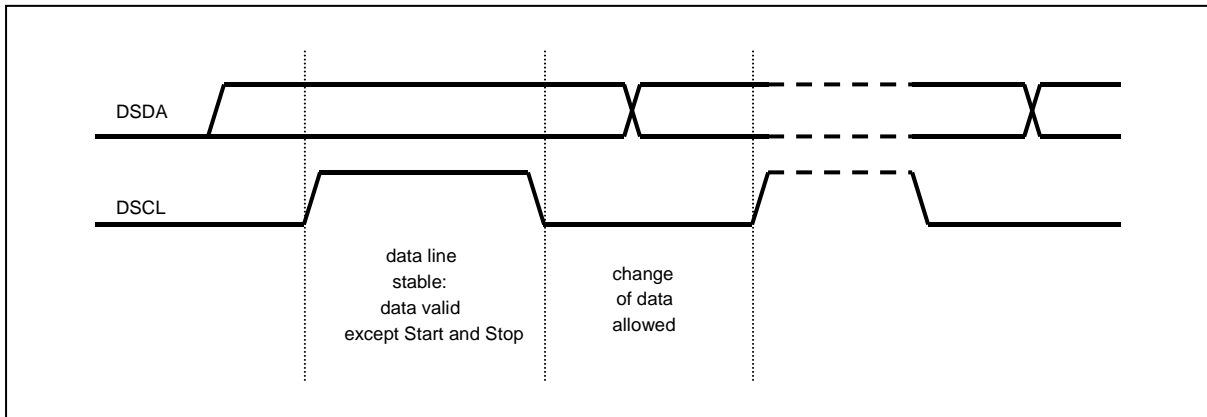

Figure 14-4 Bit Transfer on the Serial Bus

14.2.2.3 Start and stop condition

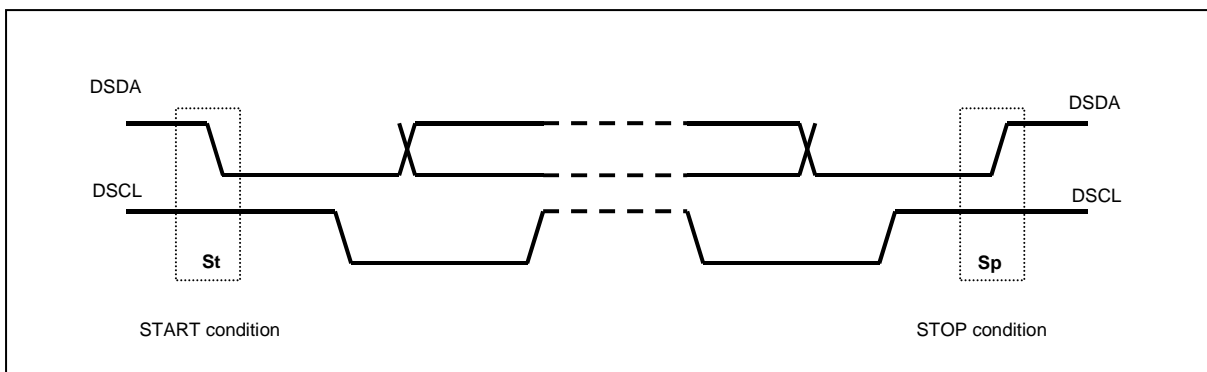

Figure 14-5 Start and Stop Condition

14.2.2.4 Acknowledge bit

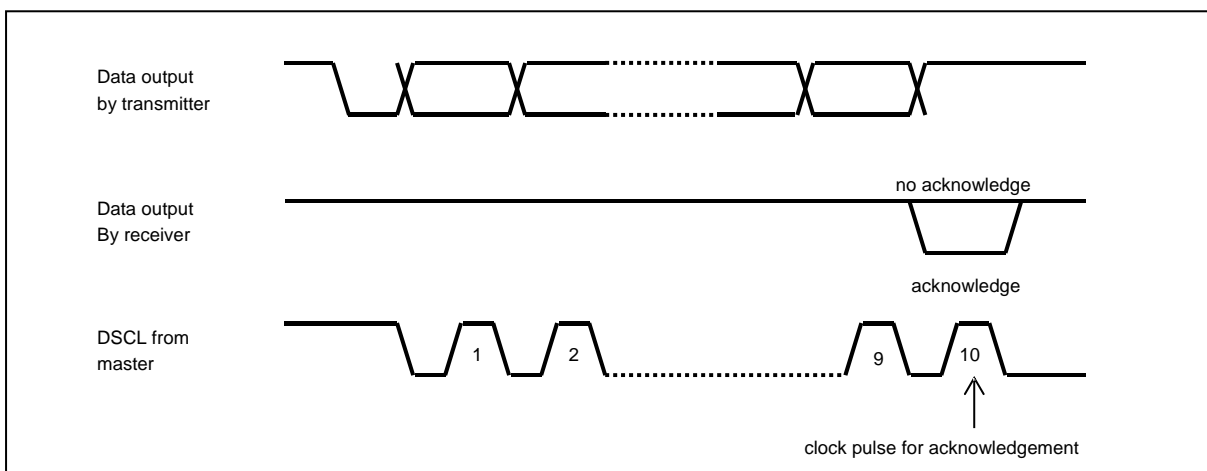

Figure 14-6 Acknowledge on the Serial Bus

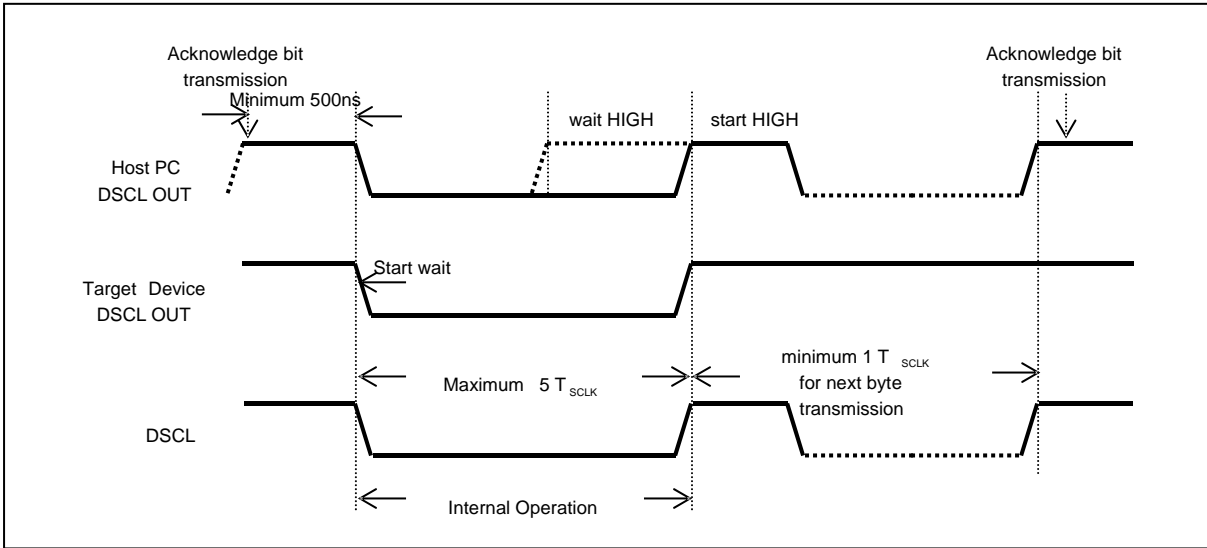

Figure 14-7 Clock Synchronization during Wait Procedure

14.2.3 Connection of Transmission

Two-pin interface connection uses open-drain (wire-AND bidirectional I/O).

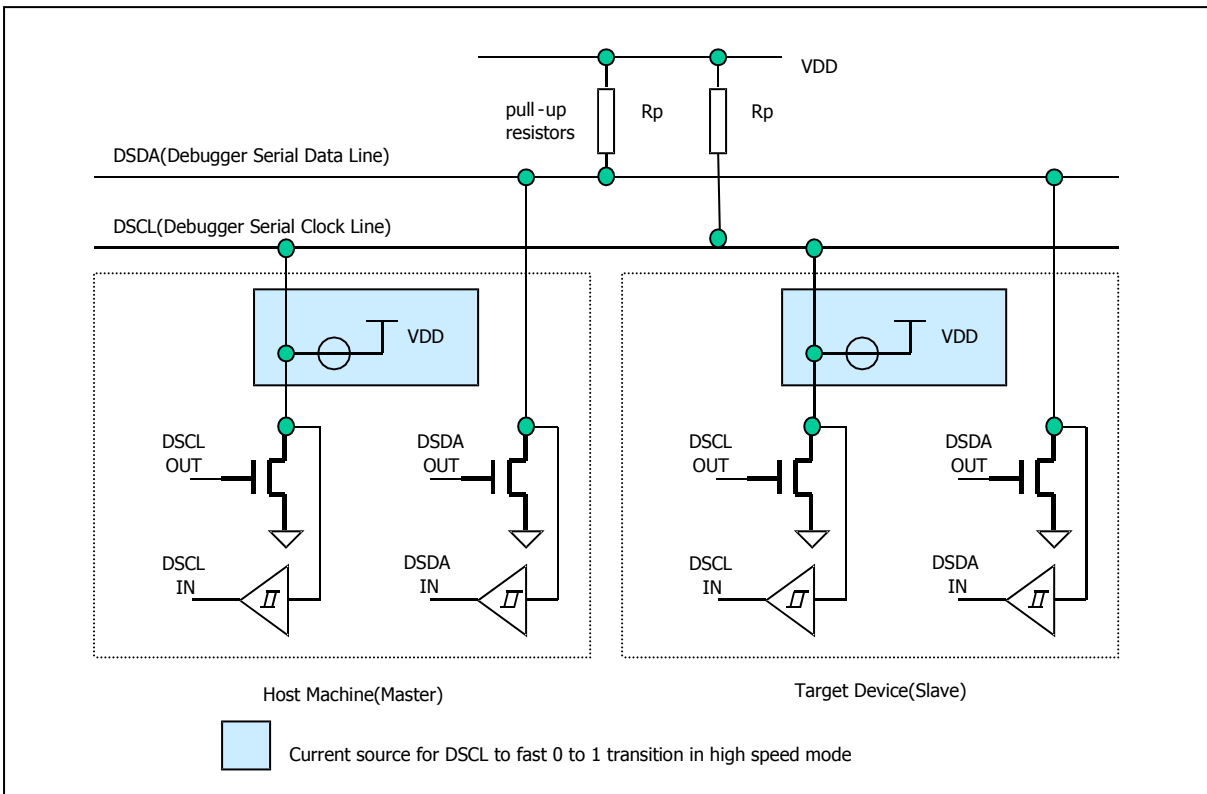

Figure 14-8 Connection of Transmission

15. Memory Programming

15.1 Overview

15.1.1 Description

MC96FT242 has flash memory to which a program can be written, erased, and overwritten while mounted on the board.

Serial ISP modes and byte-parallel ROM writer mode are supported.

15.1.2 Features

- Flash Size : 24Kbytes
- Single power supply program and erase
- Command interface for fast program and erase operation
- Up to 10,000 program/erase cycles at typical voltage and temperature for flash memory
- Security feature

15.2 Flash Control and Status Register

Registers to control Flash and Data EEPROM are Mode Register (FEMR), Control Register (FECD), Status Register (FESR), Time Control Register (FETCR), Address Low Register (FEARL), Address Middle Register (FEARM), address High Register (FEARH) and Data Register (FEDR). They are mapped to SFR area and can be accessed only in programming mode.

15.2.1 Register Map

Table 15-1 Register Map

Name	Address	Dir	Default	Description
FEMR	EAH	R/W	00H	Flash Mode Register
FECD	EBH	R/W	03H	Flash Control Register
FESR	ECH	R/W	80H	Flash Status Register
FETCR	EDH	R/W	00H	Flash Time Control Register
FEARL	F2H	R/W	00H	Flash Address Low Register
FEARM	F3H	R/W	00H	Flash Address Middle Register
FEARH	F4H	R/W	00H	Flash Address High Register
FEDR	F5H	R/W	00H	Flash Data Register

15.2.2 Register Description for Flash

FEMR (Flash Mode Register) : EAH

7	6	5	4	3	2	1	0
FSEL	-	PGM	ERASE	PBUFF	OTPE	VFY	FEEN
R/W	-	R/W	R/W	R/W	R/W	R/W	R/W

Initial value : 00H

FSEL	Select flash memory.
0	Deselect flash memory
1	Select flash memory
PGM	Enable program or program verify mode with VFY
0	Disable program or program verify mode
1	Enable program or program verify mode
ERASE	Enable erase or erase verify mode with VFY
0	Disable erase or erase verify mode
1	Enable erase or erase verify mode
PBUFF	Select page buffer
0	Deselect page buffer
1	Select page buffer
OTPE	Select OTP area instead of program memory
0	Deselect OTP area
1	Select OTP area
VFY	Set program or erase verify mode with PGM or ERASE
	Program Verify: PGM=1, VFY=1
	Erase Verify: ERASE=1, VFY=1
FEEN	Enable program and erase of Flash. When inactive, it is possible to read as normal mode
0	Disable program and erase
1	Enable program and erase

FECR (Flash Control Register) : EBH

7	6	5	4	3	2	1	0
AEF	-	EXIT1	EXIT0	WRITE	READ	nFERST	nPBRST
R/W	-	R/W	R/W	R/W	R/W	R/W	R/W

Initial value : 03H

AEF	Enable flash bulk erase mode	
0	Disable bulk erase mode of Flash memory	
1	Enable bulk erase mode of Flash memory	
EXIT[1:0]	Exit from program mode. It is cleared automatically after 1 clock	
EXIT1	EXIT0	Description
0	0	Don't exit from program mode
0	1	Don't exit from program mode
1	0	Don't exit from program mode
1	1	Exit from program mode
WRITE	Start to program or erase of Flash. It is cleared automatically after 1 clock	
0	No operation	

	1	Start to program or erase of Flash
READ	0	No operation
	1	Start auto-verify of Flash
nFERST	0	No operation
	1	Reset Flash control logic. It is cleared automatically after 1 clock
nPBRST	0	No operation
	1	Reset Flash control logic.
	Reset page buffer with PBUFF. It is cleared automatically after 1 clock	
	PBUFF	nPBRST
	0	0
	1	0
		Description
		Page buffer reset
		Write checksum reset

WRITE and READ bits can be used in program, erase and verify mode with FEAR registers. Read or writes for memory cell or page buffer uses read and write enable signals from memory controller. Indirect address mode with FEAR is only allowed to program, erase and verify

FESR (Flash Status Register) : ECH

7	6	5	4	3	2	1	0
PEVBSY	VFYGOOD	-	-	ROMINT	WMODE	EMODE	VMODE
R	RW	R	R	RW	R	R	R

Initial value : 80H

PEVBSY	Operation status flag. It is cleared automatically when operation starts. Operations are program, erase or verification
0	Busy (Operation processing)
1	Complete Operation
VFYGOOD	Auto-verification result flag.
0	Auto-verification fails
1	Auto-verification successes
ROMINT	Flash interrupt request flag. Auto-cleared when program/erase/verify starts. Active in program/erase/verify completion
0	No interrupt request.
1	Interrupt request.
WMODE	Write mode flag
EMODE	Erase mode flag
VMODE	Verify mode flag

FEARL (Flash address low Register) : F2H

7	6	5	4	3	2	1	0
ARL7	ARL6	ARL5	ARL4	ARL3	ARL2	ARL1	ARL0
W	W	W	W	W	W	W	W

Initial value : 00H

ARL[7:0] Flash address low**FEARM (Flash address middle Register) : F3H**

7	6	5	4	3	2	1	0
ARM7	ARM6	ARM5	ARM4	ARM3	ARM2	ARM1	ARM0
W	W	W	W	W	W	W	W

Initial value : 00H

ARM[7:0] Flash address middle**FEARH (Flash address high Register) : F4H**

7	6	5	4	3	2	1	0
ARH7	ARH6	ARH5	ARH4	ARH3	ARH2	ARH1	ARH0
W	W	W	W	W	W	W	W

Initial value : 00H

ARH[7:0] Flash address high

FEAR registers are used for program, erase and auto-verify. In program and erase mode, it is page address and ignored the same least significant bits as the number of bits of page address. In auto-verify mode, address increases automatically by one.

FEARs are write-only register. Reading these registers returns 24-bit checksum result

FEDR (Flash control Register) : F5H

7	6	5	4	3	2	1	0
FEDR7	FEDR6	FEDR5	FEDR4	FEDR3	FEDR2	FEDR1	FEDR0
W	W	W	W	W	W	W	W

Initial value : 00H

FEDR[7:0] Flash data

Data register. In no program/erase/verify mode, READ/WRITE of FECD read or write data from FLASH to this register or from this register to Flash.

The sequence of writing data to this register is used for EEPROM program entry. The mode entrance sequence is to write 0xA5 and 0x5A to it in order.

FETCR (Flash Time control Register) : EDH

7	6	5	4	3	2	1	0
TCR7	TCR6	TCR5	TCR4	TCR3	TCR2	TCR1	TCR0
RW	RW	RW	RW	RW	RW	RW	RW

Initial value : 00H

TCR[7:0] Flash Time control

Program and erase time is controlled by setting FETCR register. Program and erase timer uses 10-bit counter. It increases by one at each divided system clock frequency(=SCLK/128). It is cleared when program or erase starts. Timer stops when 10-bit counter is same to FETCR. PEVBSY is cleared when program, erase or verify starts and set when program, erase or verify stops.

Max program/erase time at 16MHz system clock : $(255+1) * 2 * (0.0625\text{us} * 128) = 4.096\text{ms}$

In the case of 10% of error rate of counter source clock, program or erase time is 3.6~4.5ms

* Program/erase time calculation

for page write or erase, $T_{pe} = (TCON+1) * 2 * (SCLK * 128)$

for bulk erase, $T_{be} = (TCON+1) * 4 * (SCLK * 128)$

Table 15-2 Program/Erase Time

※ Recommended program/erase time at 16MHz (FETCR = 9Ch)

	Min	Typ	Max	Unit
program/erase Time	2.4	2.5	2.6	ms

15.3 Memory map

15.3.1 Flash Memory Map

Program memory uses 24K byte of Flash memory. It is read by byte and written by byte or page. One page is 64-byte

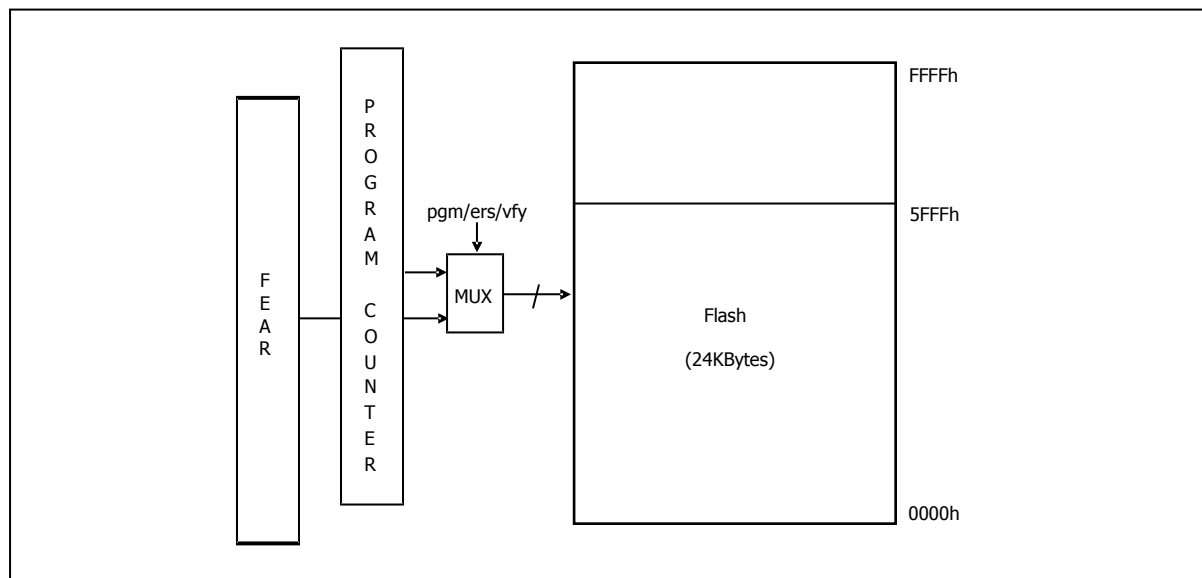

Figure 15-1 Flash Memory Map

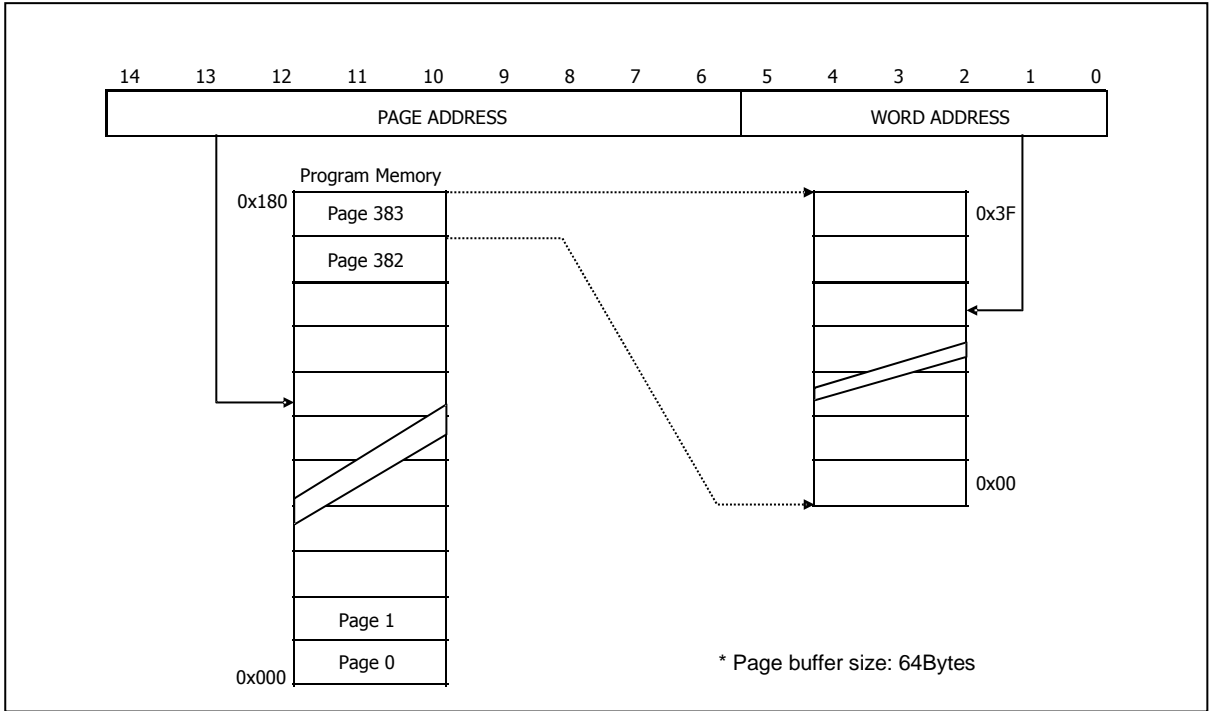

Figure 15-2 Address Configuration of Flash Memory

15.4 Serial In-System Program Mode

Serial in-system program uses the interface of debugger which uses two wires. Refer to chapter 14 in details about debugger

15.4.1 Flash Operation

Configuration(This Configuration is just used for follow description)

7	6	5	4	3	2	1	0
-	FEMR[4]&[1]	FEMR[5]&[1]	-	-	FEMR[2]	FECR[6]	FECR[7]
-	ERASE&VFY	PGM&VFY	-	-	OTPE	AEE	AEF

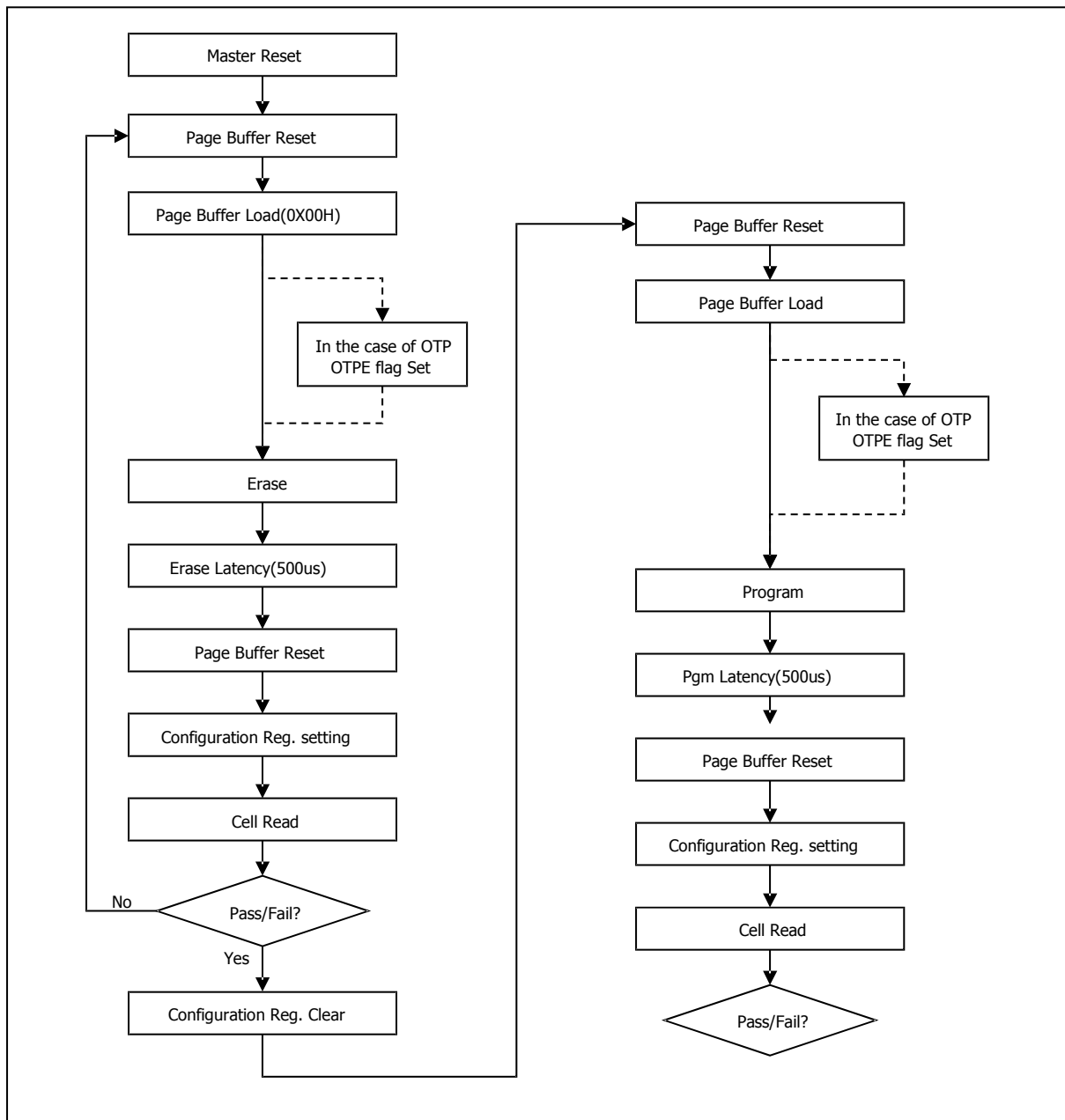

Figure 15-3 The Sequence of Page Program and Erase of Flash Memory

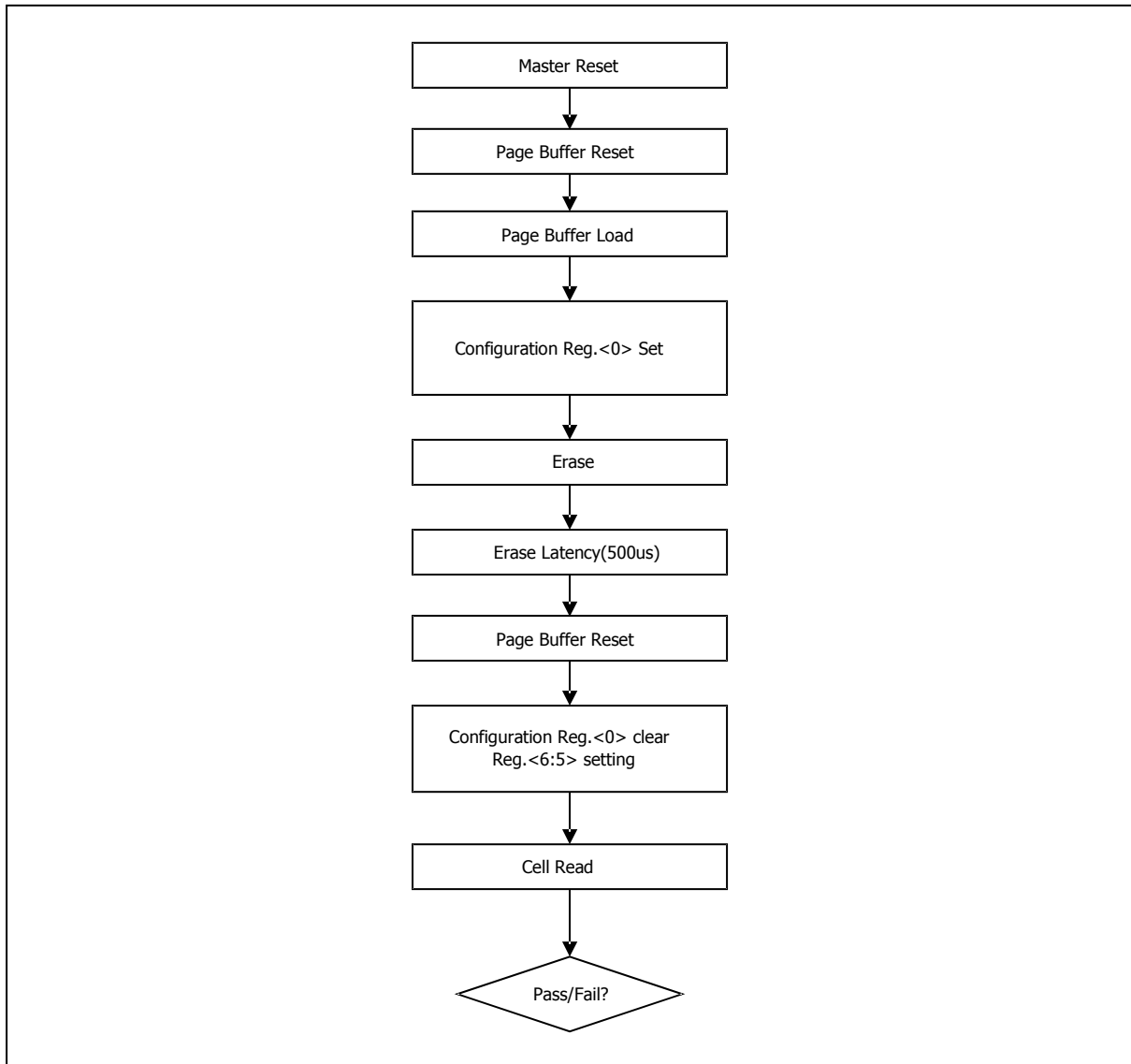

Figure 15-4 The Sequence of Bulk Erase of Flash Memory

15.4.1.1 Flash Read

- Step 1. Enter OCD(=ISP) mode.
- Step 2. Set ENBDM bit of BCR.
- Step 3. Enable debug and Request debug mode.
- Step 4. Read data from Flash.

15.4.1.2 Enable program mode

- Step 1. Enter OCD(=ISP) mode.¹
- Step 2. Set ENBDM bit of BCR.
- Step 3. Enable debug and Request debug mode.
- Step 4. Enter program/erase mode sequence.²

-
- (1) Write 0xAA to 0xF555.
 - (2) Write 0x55 to 0xFAAA.
 - (3) Write 0xA5 to 0xF555.

¹ Refer to how to enter ISP mode..

² Command sequence to activate Flash write/erase mode. It is composed of sequentially writing data of Flash memory.

15.4.1.3 Flash write mode

- Step 1. Enable program mode.
- Step 2. Reset page buffer. FEMR: 1000_0001 FECR:0000_0010
- Step 3. Select page buffer. FEMR:1000_1001
- Step 4. Write data to page buffer.(Address automatically increases by twin.)
- Step 5. Set write mode. FEMR:1010_0001
- Step 6. Set page address. FEARH:FEARM:FEARL=20'hx_xxxx
- Step 7. Set FETCR.
- Step 8. Start program. FECR:0000_1011
- Step 9. Insert one NOP operation
- Step 10. Read FESR until PEVBSY is 1.
- Step 11. Repeat step2 to step 8 until all pages are written.

15.4.1.4 Flash page erase mode

- Step 1. Enable program mode.
- Step 2. Reset page buffer. FEMR: 1000_0001 FECR:0000_0010
- Step 3. Select page buffer. FEMR:1000_1001
- Step 4. Write 'h00 to page buffer. (Data value is not important.)
- Step 5. Set erase mode. FEMR:1001_0001
- Step 6. Set page address. FEARH:FEARM:FEARL=20'hx_xxxx
- Step 7. Set FETCR.
- Step 8. Start erase. FECR:0000_1011
- Step 9. Insert one NOP operation
- Step 10. Read FESR until PEVBSY is 1.
- Step 11. Repeat step2 to step 8 until all pages are erased.

15.4.1.5 Flash bulk erase mode

- Step 1. Enable program mode.
- Step 2. Reset page buffer. FEMR: 1000_0001 FECR:0000_0010
- Step 3. Select page buffer. FEMR:1000_1001
- Step 4. Write 'h00 to page buffer. (Data value is not important.)
- Step 5. Set erase mode. FEMR:1001_0001.

(Only main cell area is erased. For bulk erase including OTP area, select OTP area.(set FEMR to 1000_1101.)

Step 6. Set FETCR

Step 7. Start bulk erase. FECR:1000_1011

Step 8. Insert one NOP operation

Step 9. Read FESR until PEVBSY is 1.

15.4.1.6 Flash OTP area read mode

Step 1. Enter OCD(=ISP) mode.

Step 2. Set ENBDM bit of BCR.

Step 3. Enable debug and Request debug mode.

Step 4. Select OTP area. FEMR:1000_0101

Step 5. Read data from Flash.

15.4.1.7 Flash OTP area write mode

Step 1. Enable program mode.

Step 2. Reset page buffer. FEMR: 1000_0001 FECR:0000_0010

Step 3. Select page buffer. FEMR:1000_1001

Step 4. Write data to page buffer.(Address automatically increases by twin.)

Step 5. Set write mode and select OTP area. FEMR:1010_0101

Step 6. Set page address. FEARH:FEARM:FEARL=20'hx_xxxx

Step 7. Set FETCR.

Step 8. Start program. FECR:0000_1011

Step 9. Insert one NOP operation

Step 10. Read FESR until PEVBSY is 1.

15.4.1.8 Flash OTP area erase mode

Step 1. Enable program mode.

Step 2. Reset page buffer. FEMR: 1000_0001 FECR:0000_0010

Step 3. Select page buffer. FEMR:1000_1001

Step 4. Write 'h00 to page buffer. (Data value is not important.)

Step 5. Set erase mode and select OTP area. FEMR:1001_0101

Step 6. Set page address. FEARH:FEARM:FEARL=20'hx_xxxx

Step 7. Set FETCR.

Step 8. Start erase. FECR:0000_1011

Step 9. Insert one NOP operation

Step 10. Read FESR until PEVBSY is 1.

15.4.1.9 Flash program verify mode

Step 1. Enable program mode.

Step 2. Set program verify mode. FEMR:1010_0011

Step 3. Read data from Flash.

15.4.1.10 OTP program verify mode

Step 1. Enable program mode.

Step 2. Set program verify mode. FEMR:1010_0111

Step 3. Read data from Flash.

15.4.1.11 Flash erase verify mode

Step 1. Enable program mode.

Step 2. Set erase verify mode. FEMR:1001_0011

Step 3. Read data from Flash.

15.4.1.12 Flash page buffer read

Step 1. Enable program mode.

Step 2. Select page buffer. FEMR:1000_1001

Step 3. Read data from Flash.

15.4.2 Summary of Flash Program/Erase Mode

Table 15-3 Operation Mode

Operation mode		Description
F L A S H	Flash read	Read cell by byte.
	Flash write	Write cell by bytes or page.
	Flash page erase	Erase cell by page.
	Flash bulk erase	Erase the whole cells.
	Flash program verify	Read cell in verify mode after programming.
	Flash erase verify	Read cell in verify mode after erase.
	Flash page buffer load	Load data to page buffer.

15.5 Parallel Mode

15.5.1 Overview

Parallel program mode transfers address and data by byte. 3-byte address can be entered by one from the least significant byte of address. If only LSB is changed, only one byte can be transferred. And if the second byte is changed, the first and second byte can be transferred. Upper 4-bit of the most significant byte selects memory to be accessed. Table 15-3 shows memory type. Address auto-increment is supported when read or write data without address

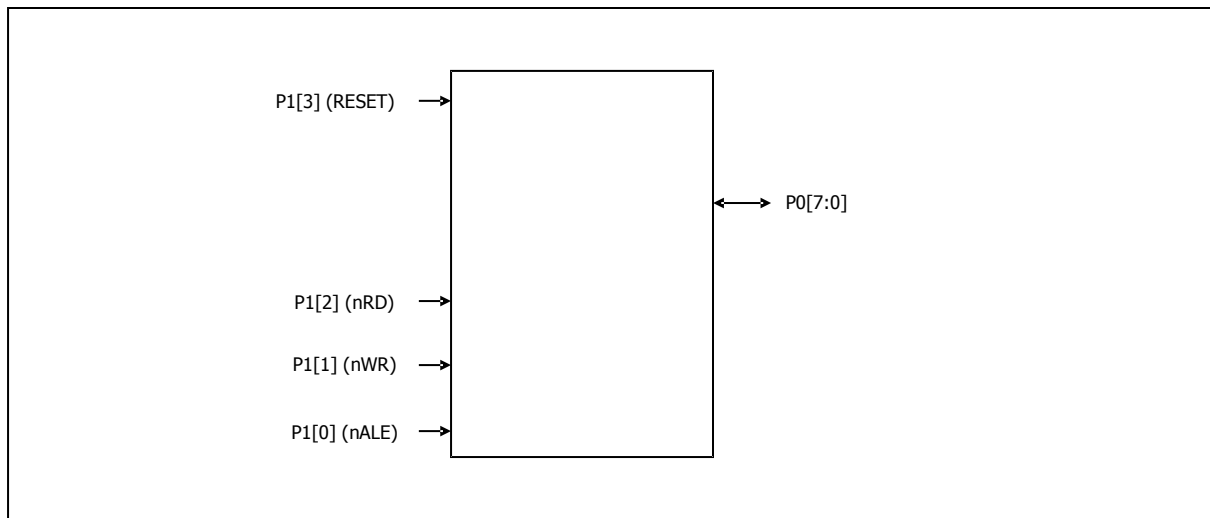

Figure 15-5 Pin Diagram for Parallel Programming

Table 15-4 The Selection of Memory Type by ADDRH[7:4]

ADDRH[7:4]				Memory Type
0	0	0	0	Program Memory
0	0	0	1	External Memory
0	0	1	0	SFR

15.5.2 Parallel Mode Instruction Format

Instruction	Signal	Instruction Sequence													
n-byte data read with 3-byte address	nALE	L		L		L		H		H		H		H	
	nWR	L	H	L	H	L	H	H	H	H	H	H	H	H	H
	nRD	H	H	H	H	H	H	L	H	L	H	L	H	L	H
	PDATA	ADDRL		ADDRM		ADDRH		DATA0		DATA1		---		DATAn	
n-byte data write with 3-byte address	nALE	L		L		L		H		H		H		H	
	nWR	L	H	L	H	L	H	L	H	L	H	L	H	L	H

	nRD	H	H	H	H	H	H	H	H	H	H	H	H	H	H	
	PDATA	ADDRL			ADDRM			ADDRH			DATA0	DATA1	---	DATAn		
n-byte data read with 2-byte address	nALE	L			L			H			H			H		
	nWR	L	H	L	H	H	H	H	H	H	H	H	H	H	H	
	nRD	H	H	H	H	L	H	L	H	L	H	L	H	L	H	
	PDATA	ADDRL			ADDRM			DATA0			DATA1	DATA2	---	DATAn		
n-byte data write with 2-byte address	nALE	L			L			H			H			H		
	nWR	L	H	L	H	L	H	L	H	L	H	L	H	L	H	
	nRD	H	H	H	H	H	H	H	H	H	H	H	H	H	H	
	PDATA	ADDRL			ADDRM			DATA0			DATA1	DATA2	---	DATAn		
n-byte data read with 1-byte address	nALE	L			H			H			H			H		
	nWR	L	H	H	H	L	H	L	H	L	H	L	H	L	H	
	nRD	H	H	L	H	H	H	H	H	H	H	H	H	H	H	
	PDATA	ADDRL			DATA0			DATA1			DATA2	DATA3	---	DATAn		
n-byte data write with 1-byte address	nALE	L			H			H			H			H		
	nWR	L	H	L	H	L	H	L	H	L	H	L	H	L	H	
	nRD	H	H	H	H	H	H	H	H	H	H	H	H	H	H	
	PDATA	ADDRL			DATA0			DATA1			DATA2	DATA3	---	DATAn		

15.5.3 Parallel Mode Timing diagram

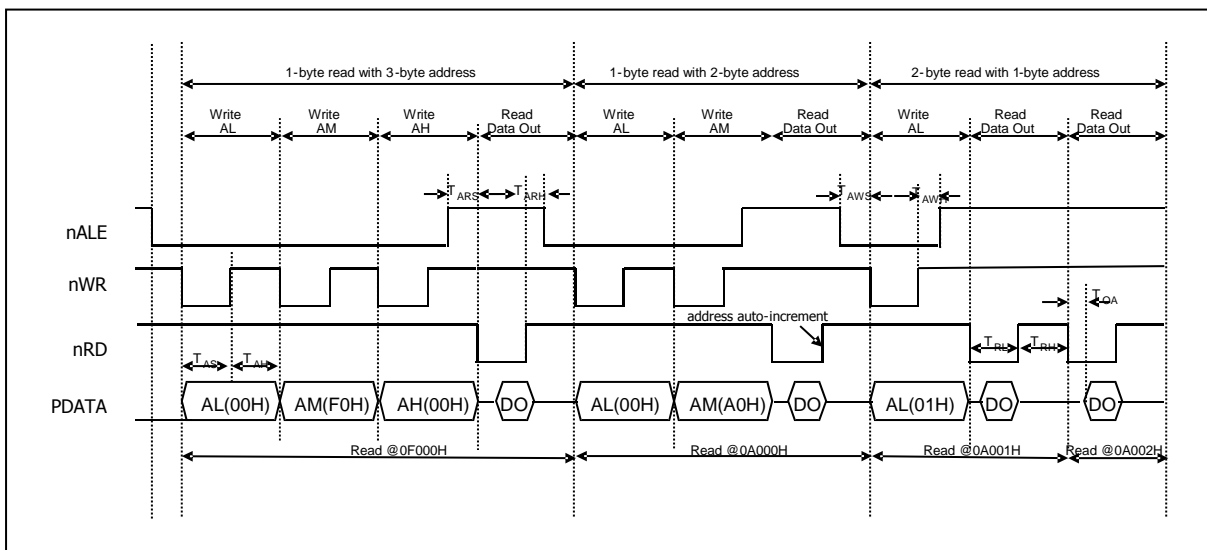

Figure 15-6 Parallel Byte Read Timing of Program Memory

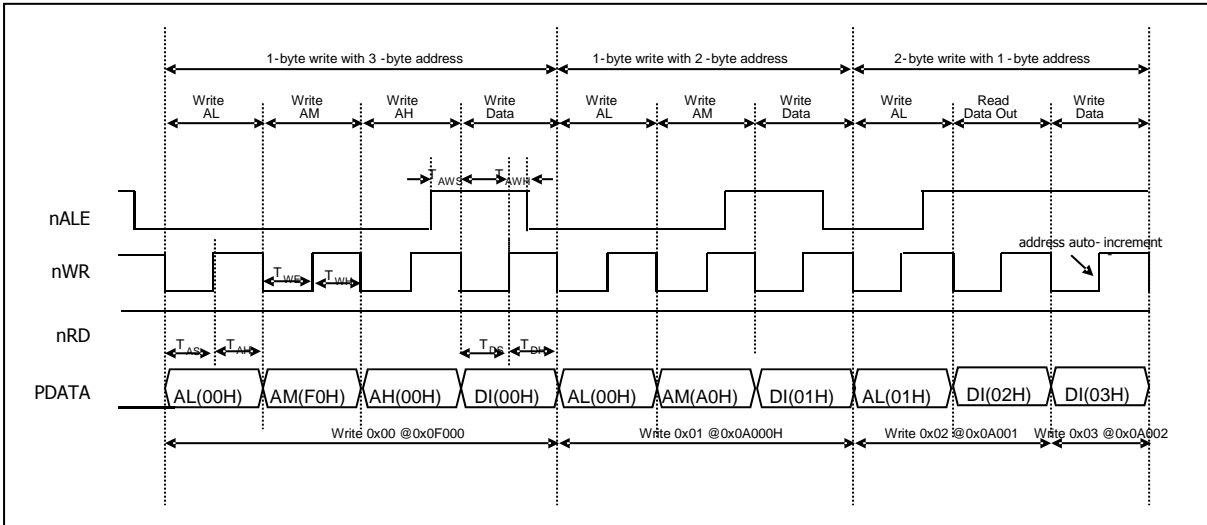

Figure 15-7 Parallel Byte Write Timing of Program Memory

15.6 Mode Entrance Method of ISP and byte-parallel Mode

15.6.1 Mode Entrance Method for ISP

TARGET MODE	DSDA	DSCL	DSDA
OCD(ISP)	'hC	'hC	'hC

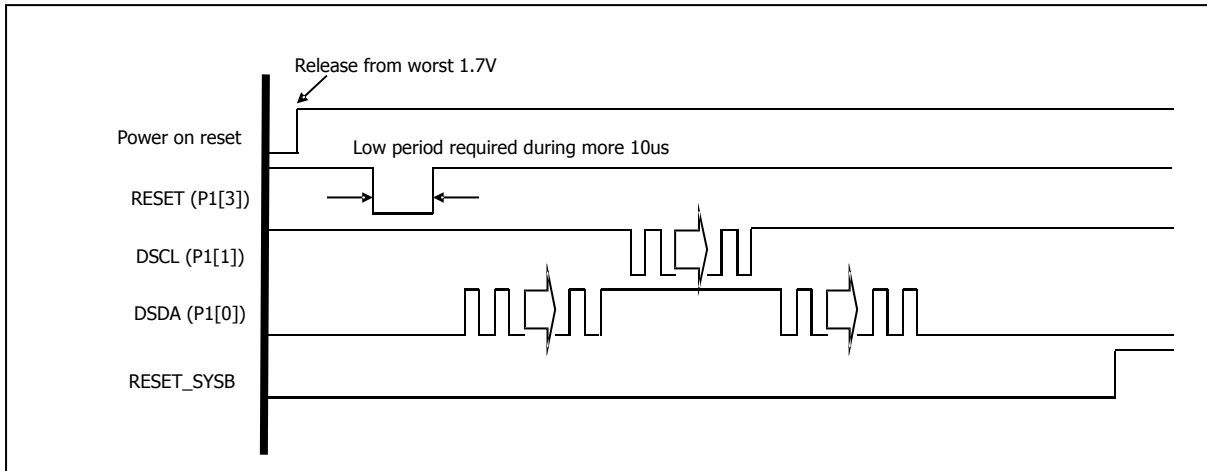

Figure 15-8 ISP Mode

15.6.2 Mode Entrance of Byte-parallel

TARGET MODE	P0[3:0]	P0[3:0]	P0[3:0]
Byte-Parallel Mode	4'h5	4'hA	4'h5

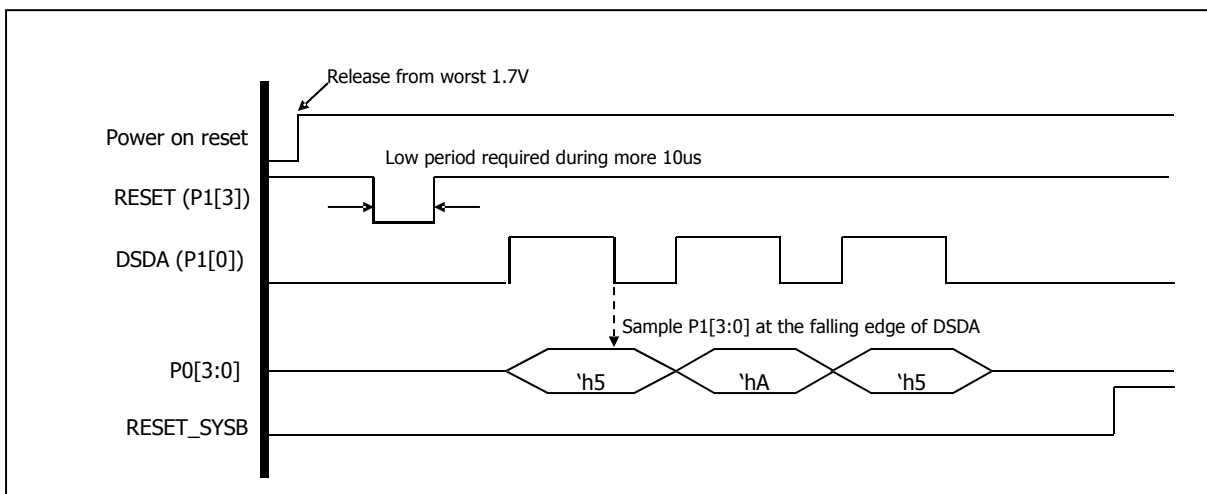

Figure 15-9 Byte-parallel Mode

15.7 Security

MC96FT242 provides Lock bits which can be left un-programmed (“0”) or can be programmed (“1”) to obtain the additional features listed in Table 15-5. The Lock bit can only be erased to “0” with the bulk erase command and a value of more than 0x80 at FETCR.

Table 15-5 Security Policy using Lock-bits

LOCK MODE	USER MODE								ISP/PMODE							
	FLASH				OTP				FLASH				OTP			
LOCKF	R	W	PE	BE	R	W	PE	BE	R	W	PE	BE	R	W	PE	BE
0	O	O	O	X	X	X	X	X	O	O	O	O	O	O	O	O
1	O	O	O	X	X	X	X	X	X	X	X	O	O	X	X	O

- LOCKF: Lock bit of Flash memory
- R: Read
- W: Write
- PE: Page erase
- BE: Bulk Erase
- O: Operation is possible.
- X: Operation is impossible.

16. Configure Option

16.1 Configure Option Control Register

FUSE_CONF (Pseudo-Configure Data) : 2F5DH

7	6	5	4	3	2	1	0
BSIZE1	BSIZE0	-	-	RSTEN	LOCKB	-	LOCKF
R	R	-	-	R	R	-	R

Initial value : 00H

- BSIZE** Select Specific Area (Boot Area) for Write Protection
 Note) When LOCKB = '1', it is applied
- 00 256B (0100H~01FFH) (default)
 - 01 768B (0100H~03FFH)
 - 10 1,792B (0100H~07FFH)
 - 11 3,840B (0100H~0FFFH)
- RSTEN** Select RESETB pin function
- 0 **Disable External RESETB pin (default)**
 - 1 Enable External RESETB pin
- LOCKB** Enable Specific Area (Boot Area) Write Protection
- 0 LOCK Disable
 - 1 LOCK Enable
- LOCKF** CODE memory Read Protection
- 0 LOCK Disable
 - 1 LOCK Enable

17. APPENDIX

A. Instruction Table

Instructions are either 1, 2 or 3 bytes long as listed in the 'Bytes' column below.

Each instruction takes either 1, 2 or 4 machine cycles to execute as listed in the following table. 1 machine cycle comprises 2 system clock cycles.

ARITHMETIC				
Mnemonic	Description	Bytes	Cycles	Hex code
ADD A,Rn	Add register to A	1	1	28-2F
ADD A,dir	Add direct byte to A	2	1	25
ADD A,@Ri	Add indirect memory to A	1	1	26-27
ADD A,#data	Add immediate to A	2	1	24
ADDC A,Rn	Add register to A with carry	1	1	38-3F
ADDC A,dir	Add direct byte to A with carry	2	1	35
ADDC A,@Ri	Add indirect memory to A with carry	1	1	36-37
ADDC A,#data	Add immediate to A with carry	2	1	34
SUBB A,Rn	Subtract register from A with borrow	1	1	98-9F
SUBB A,dir	Subtract direct byte from A with borrow	2	1	95
SUBB A,@Ri	Subtract indirect memory from A with borrow	1	1	96-97
SUBB A,#data	Subtract immediate from A with borrow	2	1	94
INC A	Increment A	1	1	04
INC Rn	Increment register	1	1	08-0F
INC dir	Increment direct byte	2	1	05
INC @Ri	Increment indirect memory	1	1	06-07
DEC A	Decrement A	1	1	14
DEC Rn	Decrement register	1	1	18-1F
DEC dir	Decrement direct byte	2	1	15
DEC @Ri	Decrement indirect memory	1	1	16-17
INC DPTR	Increment data pointer	1	2	A3
MUL AB	Multiply A by B	1	4	A4
DIV AB	Divide A by B	1	4	84
DA A	Decimal Adjust A	1	1	D4

LOGICAL				
Mnemonic	Description	Bytes	Cycles	Hex code
ANL A,Rn	AND register to A	1	1	58-5F
ANL A,dir	AND direct byte to A	2	1	55
ANL A,@Ri	AND indirect memory to A	1	1	56-57
ANL A,#data	AND immediate to A	2	1	54
ANL dir,A	AND A to direct byte	2	1	52
ANL dir,#data	AND immediate to direct byte	3	2	53
ORL A,Rn	OR register to A	1	1	48-4F
ORL A,dir	OR direct byte to A	2	1	45
ORL A,@Ri	OR indirect memory to A	1	1	46-47
ORL A,#data	OR immediate to A	2	1	44
ORL dir,A	OR A to direct byte	2	1	42
ORL dir,#data	OR immediate to direct byte	3	2	43
XRL A,Rn	Exclusive-OR register to A	1	1	68-6F

XRL A,dir	Exclusive-OR direct byte to A	2	1	65
XRL A,@Ri	Exclusive-OR indirect memory to A	1	1	66-67
XRL A,#data	Exclusive-OR immediate to A	2	1	64
XRL dir,A	Exclusive-OR A to direct byte	2	1	62
XRL dir,#data	Exclusive-OR immediate to direct byte	3	2	63
CLR A	Clear A	1	1	E4
CPL A	Complement A	1	1	F4
SWAP A	Swap Nibbles of A	1	1	C4
RL A	Rotate A left	1	1	23
RLC A	Rotate A left through carry	1	1	33
RR A	Rotate A right	1	1	03
RRC A	Rotate A right through carry	1	1	13

DATA TRANSFER				
Mnemonic	Description	Bytes	Cycles	Hex code
MOV A,Rn	Move register to A	1	1	E8-EF
MOV A,dir	Move direct byte to A	2	1	E5
MOV A,@Ri	Move indirect memory to A	1	1	E6-E7
MOV A,#data	Move immediate to A	2	1	74
MOV Rn,A	Move A to register	1	1	F8-FF
MOV Rn,dir	Move direct byte to register	2	2	A8-AF
MOV Rn,#data	Move immediate to register	2	1	78-7F
MOV dir,A	Move A to direct byte	2	1	F5
MOV dir,Rn	Move register to direct byte	2	2	88-8F
MOV dir,dir	Move direct byte to direct byte	3	2	85
MOV dir,@Ri	Move indirect memory to direct byte	2	2	86-87
MOV dir,#data	Move immediate to direct byte	3	2	75
MOV @Ri,A	Move A to indirect memory	1	1	F6-F7
MOV @Ri,dir	Move direct byte to indirect memory	2	2	A6-A7
MOV @Ri,#data	Move immediate to indirect memory	2	1	76-77
MOV DPTR,#data	Move immediate to data pointer	3	2	90
MOVC A,@A+DPTR	Move code byte relative DPTR to A	1	2	93
MOVC A,@A+PC	Move code byte relative PC to A	1	2	83
MOVX A,@Ri	Move external data(A8) to A	1	2	E2-E3
MOVX A,@DPTR	Move external data(A16) to A	1	2	E0
MOVX @Ri,A	Move A to external data(A8)	1	2	F2-F3
MOVX @DPTR,A	Move A to external data(A16)	1	2	F0
PUSH dir	Push direct byte onto stack	2	2	C0
POP dir	Pop direct byte from stack	2	2	D0
XCH A,Rn	Exchange A and register	1	1	C8-CF
XCH A,dir	Exchange A and direct byte	2	1	C5
XCH A,@Ri	Exchange A and indirect memory	1	1	C6-C7
XCHD A,@Ri	Exchange A and indirect memory nibble	1	1	D6-D7

BOOLEAN				
Mnemonic	Description	Bytes	Cycles	Hex code
CLR C	Clear carry	1	1	C3
CLR bit	Clear direct bit	2	1	C2
SETB C	Set carry	1	1	D3
SETB bit	Set direct bit	2	1	D2

CPL C	Complement carry	1	1	B3
CPL bit	Complement direct bit	2	1	B2
ANL C,bit	AND direct bit to carry	2	2	82
ANL C,/bit	AND direct bit inverse to carry	2	2	B0
ORL C,bit	OR direct bit to carry	2	2	72
ORL C,/bit	OR direct bit inverse to carry	2	2	A0
MOV C,bit	Move direct bit to carry	2	1	A2
MOV bit,C	Move carry to direct bit	2	2	92

BRANCHING				
Mnemonic	Description	Bytes	Cycles	Hex code
ACALL addr 11	Absolute jump to subroutine	2	2	11→F1
LCALL addr 16	Long jump to subroutine	3	2	12
RET	Return from subroutine	1	2	22
RETI	Return from interrupt	1	2	32
AJMP addr 11	Absolute jump unconditional	2	2	01→E1
LJMP addr 16	Long jump unconditional	3	2	02
SJMP rel	Short jump (relative address)	2	2	80
JC rel	Jump on carry = 1	2	2	40
JNC rel	Jump on carry = 0	2	2	50
JB bit,rel	Jump on direct bit = 1	3	2	20
JNB bit,rel	Jump on direct bit = 0	3	2	30
JBC bit,rel	Jump on direct bit = 1 and clear	3	2	10
JMP @A+DPTR	Jump indirect relative DPTR	1	2	73
JZ rel	Jump on accumulator = 0	2	2	60
JNZ rel	Jump on accumulator ≠ 0	2	2	70
CJNE A,dir,rel	Compare A,direct jne relative	3	2	B5
CJNE A,#d,rel	Compare A,immediate jne relative	3	2	B4
CJNE Rn,#d,rel	Compare register, immediate jne relative	3	2	B8-BF
CJNE @Ri,#d,rel	Compare indirect, immediate jne relative	3	2	B6-B7
DJNZ Rn,rel	Decrement register, jnz relative	2	2	D8-DF
DJNZ dir,rel	Decrement direct byte, jnz relative	3	2	D5

MISCELLANEOUS				
Mnemonic	Description	Bytes	Cycles	Hex code
NOP	No operation	1	1	00

ADDITIONAL INSTRUCTIONS (selected through EO[7:4])				
Mnemonic	Description	Bytes	Cycles	Hex code
MOVC @(DPTR++),A	M8051W/M8051EW-specific instruction supporting software download into program memory	1	2	A5
TRAP	Software break command	1	1	A5

In the above table, an entry such as E8-EF indicates a continuous block of hex op-codes used for 8 different registers, the register numbers of which are defined by the lowest three bits of the corresponding code. Non-continuous blocks of codes, shown as 11→F1 (for example), are used for absolute jumps and calls, with the top 3 bits of the code being used to store the top three bits of the destination address.

The CJNE instructions use the abbreviation #d for immediate data; other instructions use #data.

B. Package relation

	MC96FT242U	MC96FT242L	MC96FT242D	MC96FT202D	MC96FT162D
Pin count	32	32	32	28	24
Max I/O	30	30	30	26	22
Difference	-		-	-	
(removed	-		-	-	
functions	-		-	-	
on standard	-		-	-	
MC96FT242)	-		-	-	