

# SPECIFICATION FOR APPROVAL

## 产品承认书

CUSTOMER: \_\_\_\_\_

CUSTOMER NO. : \_\_\_\_\_

HSW PART NO. : \_\_\_\_\_

**HS1024G**

DESCRIPTION:

10/100/1000 BASE-T DUAL PORT SMD MODULE

ATTACHMENT:

■ SPECIFICATION

■ SAMPLE

Q'TY OF SAMPLES

**3**

PCS

**CUSTOMER APPROVAL**

(客户承认章)

**HSW APPROVAL**

(公司承认章)

SALES BY:

SALES BY:

张静

QA DEPT. :

CHECKED BY:

刘君

ENG. DEPT.:

APPROVAL BY:

贺江

深圳市华升微电子有限公司

TEL:86-755- 33272179/33270812

FAX:86-755-61174076

[www.h1102.com](http://www.h1102.com)

[sales@h1102.com](mailto:sales@h1102.com)

hswdz01@163.com

PLEASE REPLY THIS SHEET TO US AFTER SIGNATURE(请签字后回传本页)



## INDEX

1. Index-----	1
2. Record of Revision-----	2
3. Mechanical drawing-----	3
4. Schematic drawing -----	4
5. Sample Test Report-----	5
6. Packing info-----	6
7. Recommended Reflow Soldering curve,Reliability-----	7
8. Material Certificate List-----	8
9. UL certification-----	9

<http://www.h1102.com> E-mail:sales@h1102.com TEL : 0755-33272179/0812





## 1. Mechanical Drawing:

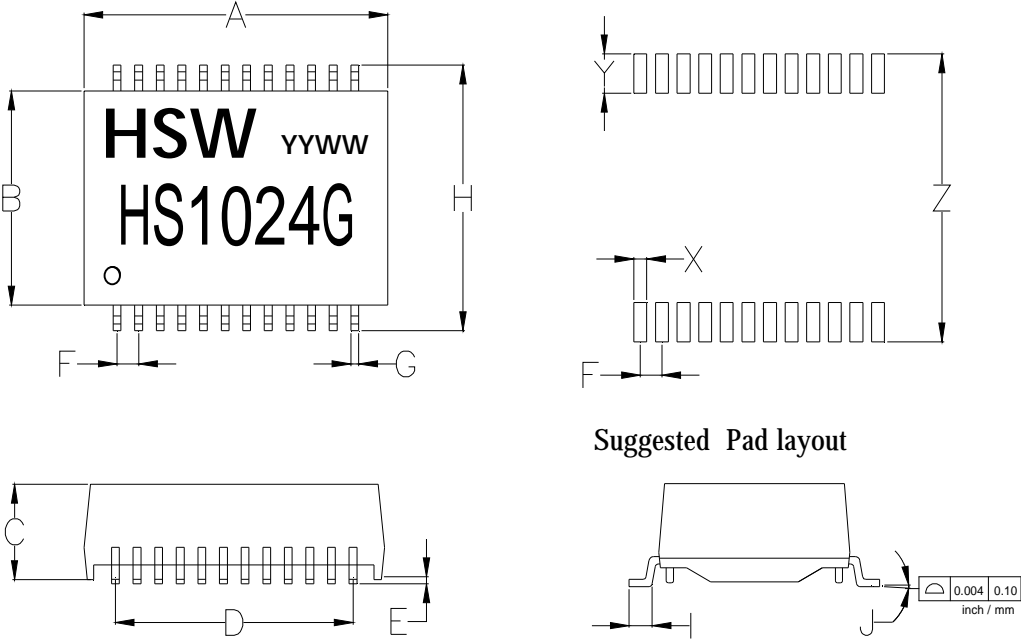

DIM	MILLIMETERS		INCHES	
	MIN	MAX	MIN	MAX
A	17.63	18.63	0.699	0.733
B	11.70	12.70	0.461	0.500
C	6.80(max)		0.268(max)	
D	13.97(typical)		0.550(typical)	
E	0.15	0.45	0.006	0.018
F	1.27(typical)		0.050(typical)	
G	0.46(typical)		0.018(typical)	
H	15.50	16.50	0.610	0.650
I	0°	8°	0°	8°
J	1.27(typical)		0.05(typical)	
X	0.76(typical)		0.030(typical)	
Y	2.29(typical)		0.090(typical)	
Z	16.76(typical)		0.660(typical)	



## 2. Schematic:

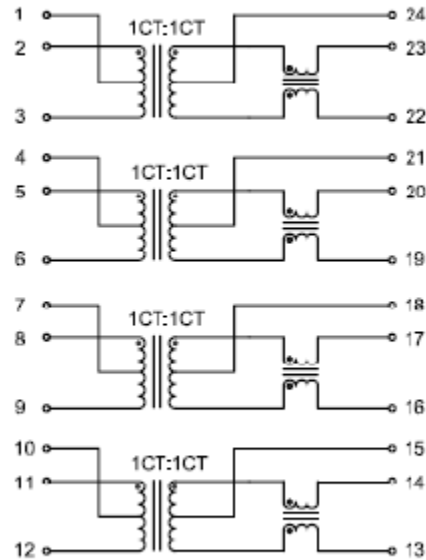

## 3. Electrical Specification @25°C

Inductance OCL:	350uH Min @ 100KHz 0.1V 8mA DC BIAS	
Leakage Inductance:	0.50uH Max @ 100KHz 0.1V	
Interwinding Capacitance:	25pF Typ @ 100KHz 0.1V	
DC Resistance:	1.2Ω Max	
Turn Ratio:	1CT:1CT±5%	
Polarity:	2-23,5-20,8-17,11-14 In-Phase	
Insertion Loss:	0.5-100 MHz	-1.1dB Max
Return Loss:	0.5-40MHz	-18dB Min
	40.1-100MHz	-12+20*log(f/80)dB Min
Cross Talk:	0.5-40MHz	-35dB Min
	40.1-100MHz	-33+20*log(f/50)dB Min
CMRR:	0.5-100MHz	-30dB Min
Isolation HI-POT:	1500VAC,1mA,1s	
Operating Temperature:	0°C to 70°C	
Product Type:	Green Product	

# 深圳市华升微电子有限公司



NO	1	2	3	4	5
SPEC					
L:(AT 100KHz 0.1V 8mA)					
350uH Min					
2-3	612	598	599	589	612
5-6	598	592	613	592	609
8-9	603	614	615	619	623
11-12	612	623	606	608	609
LK:(AT 100KHz 0.1V)					
0.5uH Max					
2-3(23-22short)	0.21	0.25	0.19	0.26	0.17
5-6(20-19 short)	0.22	0.26	0.25	0.24	0.16
8-9(17-16 short)	0.18	0.19	0.26	0.18	0.19
11-12(14-13 short)	0.24	0.25	0.18	0.24	0.23
CWW:(AT 100KHz 0.1V)					
25pF Typ					
2-3 TO 23-22	18.6	22.3	20.9	20.5	23.1
5-6 TO 20-19	18.3	20.3	22.3	20.1	25.2
8-9 TO 17-16	19.2	19.8	19.5	22.4	15.2
11-12 TO 14-13	20.3	19.4	18.5	23.6	19.2
DCR:(AT 25°C)					
1.2Ω Max					
23-22	0.87	0.81	0.82	0.80	0.82
20-19	0.82	0.70	0.81	0.78	0.83
17-16	0.79	0.81	0.78	0.82	0.81
14-13	0.79	0.79	0.79	0.79	0.82
URNS RATIO:					
(2-3):(23-22)=1CT:1CT±5%	OK	OK	OK	OK	OK
(5-6):(20-19)=1CT:1CT±5%	OK	OK	OK	OK	OK
(8-9):(17-16)=1CT:1CT±5%	OK	OK	OK	OK	OK
(11-12):(14-13)=1CT:1CT±5%	OK	OK	OK	OK	OK
HI-POT:					
AT:1500VAC 1mA 1S					
2-3 TO 23-22	OK	OK	OK	OK	OK
5-6 TO 20-19	OK	OK	OK	OK	OK
8-9 TO 17-16	OK	OK	OK	OK	OK
11-12 TO 14-13	OK	OK	OK	OK	OK



## 4. Package Information:

### 1. Packaging Method is as below:

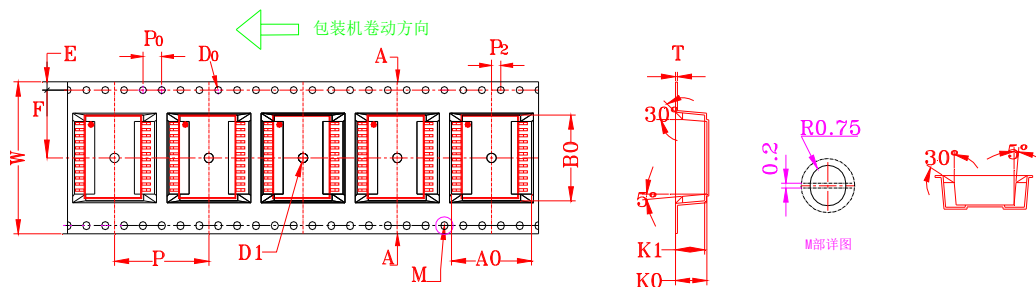

ITEM	W	A <sub>0</sub>	B <sub>0</sub>	K <sub>0</sub>	K <sub>1</sub>	P	F	E	D <sub>0</sub>	D <sub>1</sub>	P <sub>0</sub>	P <sub>2</sub>	T
DIM	32.00 <sup>+0.30</sup> <sub>-0.30</sub>	17.0 <sup>+0.10</sup> <sub>-0.10</sub>	18.10 <sup>+0.10</sup> <sub>-0.10</sub>	6.70 <sup>+0.10</sup> <sub>-0.10</sub>	6.20 <sup>+0.10</sup> <sub>-0.10</sub>	20.00 <sup>+0.10</sup> <sub>-0.10</sub>	14.2 <sup>+0.10</sup> <sub>-0.10</sub>	1.75 <sup>+0.10</sup> <sub>-0.10</sub>	1.50 <sup>+0.10</sup> <sub>-0.10</sub>	2.00 <sup>+0.10</sup> <sub>-0.10</sub>	4.00 <sup>+0.10</sup> <sub>-0.10</sub>	2.00 <sup>+0.10</sup> <sub>-0.10</sub>	0.40 <sup>+0.05</sup> <sub>-0.05</sub>
ALTERNATE													

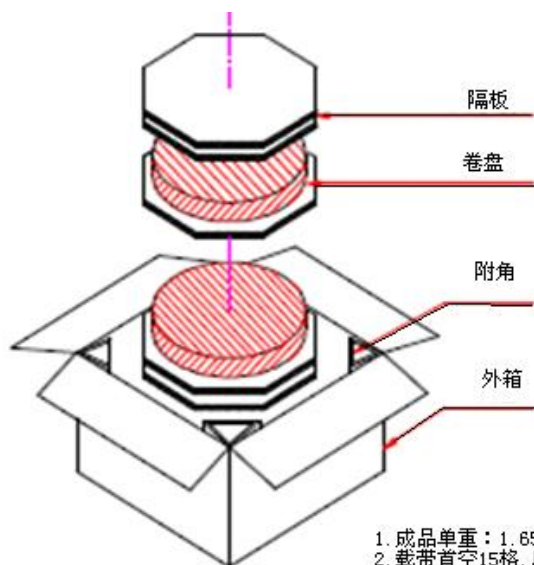

1. 成品单重: 1.65g, 每卷400pcs, 每箱2000pcs, 共5卷
2. 载带首空15格, 后空15格子
3. 每卷间垫1pcs隔板, 四角放置4pcs附角

### 2. Package Q'ty:

400 units/reel

5 reel/carton

2000 units/carton



## 5. Recommended Reflow Soldering Curve:

### IR reflow graph

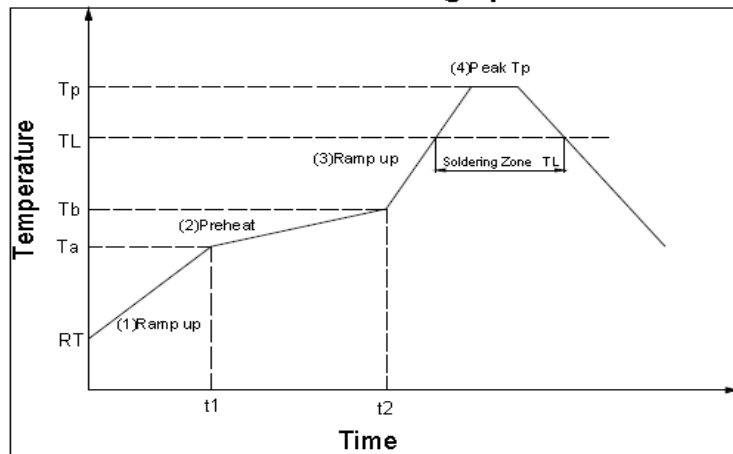

### IR reflow profile

Form-1 (Reference JEDEC J-STD-020C Table 5-2)

IR reflow profile		Sn-Pb	Pb-free
step#	Profile Feature	Condition/Duration	Condition/Duration
step1	Ramp-up rate	1.5-3°C/sec.	1.5-3°C/sec.
step2	Preheat : 100~150°C(Ta-Tb)	t1-t2 : 60~120 sec.	t1-t2 : 60~180 sec.
step3	Ramp-up rate(T <sub>L</sub> to T <sub>P</sub> )	1.5-3°C/sec.	1.5-3°C/sec.
	Temperature maintained above 183°C(T <sub>L</sub> )	T <sub>L</sub> :60-150sec.	T <sub>L</sub> :80-150sec.
step4	Peak temperature(T <sub>P</sub> )	230 +5/-10 °C	260 +0/-5 °C
	Time within 5°C of actual peak temperature	30±10 sec.	30±10 sec.
step5	Ramp-down rate	6 °C/sec.Max	6 °C/sec.Max
Note1	Subject the samples to 3 cycles of the above defined reflow conditions		Subject the samples to 3 cycles of the above defined reflow conditions
Note2	Time 25 °C to peak temperature : 6 minutes max.		Time 25 °C to peak temperature : 8 minutes max.
Note3			The time between reflows shall be 5 minutes minimum and 60minutes maximum

SnPb Eutectic Process- "Package Peak Reflow Temperature"

Form-2 (Reference JEDEC J-STD-020C Table 4-1)

产品厚度	产品体积 < 350mm <sup>3</sup>	产品体积 ≥ 350mm <sup>3</sup>
< 2.5mm	240 +0/-5 °C	225 +0/-5 °C
≥ 2.5mm	225 +0/-5 °C	225 +0/-5 °C

Pb-free Process - "Package Peak Reflow Temperature"

Form-3 (Reference JEDEC J-STD-020C Table 4-2)

产品厚度	产品体积 < 350mm <sup>3</sup>	产品体积 350mm <sup>3</sup> -2000mm <sup>3</sup>	产品体积 > 2000mm <sup>3</sup>
< 1.6mm	260 +0/-5 °C	260 +0/-5 °C	260 +0/-5 °C
1.6mm-2.5mm	260 +0/-5 °C	250 +0/-5 °C	245 +0/-5 °C
> 2.5mm	250 +0/-5 °C	245 +0/-5 °C	245 +0/-5 °C





## 5. Reliability:

Reliability																								
No.	Test Item	Refer To Standard	Test Condition																					
1	Resistance To Soldering Heat--Convection Reflow	IPC/JEDEC J-STD-020D	1).Peak Temperature: Refer to Specification According to Package Body Thickness And Volume 2).Preheat Temperature and Soak Time: 150~200°C,60~120 Seconds 3).Average Ramp-up Rate: 3°C/Second Max 4).Above 217°C: 60~150 Seconds 5).Peak Temperature-5°C: Over 30 S																					
2	Thermal Shock	IEC68-2-14 Method A	1.Low Temperature:-40°C 2.High Temperature:125 3.Dwell Time:30 Minutes 4.Transition Time: Less Than 5Minutes 5.Number of Cycles: 10																					
3	High Temperature	IEC68-2-2 Method A	125°C ,96Hours																					
4	Low Temperature	IEC68-2-1 Method A	-40°C ,96Hours																					
5	Temperature Humidity Cycle	IEC68-2-38	<table border="1" style="width: 100%; border-collapse: collapse;"> <thead> <tr> <th>Temp</th> <th>Humidity</th> <th>soak time</th> </tr> </thead> <tbody> <tr> <td>25~65°C</td> <td>93+/-3%RH</td> <td>1.5 hr</td> </tr> <tr> <td>65°C</td> <td>93+/-3%RH</td> <td>4 hr</td> </tr> <tr> <td>65~25°C</td> <td>80~96%RH</td> <td>2.5 hr</td> </tr> <tr> <td>25~65°C</td> <td>93+/-3%RH</td> <td>1.5hr</td> </tr> <tr> <td>65°C</td> <td>93+/-3%RH</td> <td>4hr</td> </tr> <tr> <td>65~25°C</td> <td>80~96%RH</td> <td>2</td> </tr> </tbody> </table>	Temp	Humidity	soak time	25~65°C	93+/-3%RH	1.5 hr	65°C	93+/-3%RH	4 hr	65~25°C	80~96%RH	2.5 hr	25~65°C	93+/-3%RH	1.5hr	65°C	93+/-3%RH	4hr	65~25°C	80~96%RH	2
Temp	Humidity	soak time																						
25~65°C	93+/-3%RH	1.5 hr																						
65°C	93+/-3%RH	4 hr																						
65~25°C	80~96%RH	2.5 hr																						
25~65°C	93+/-3%RH	1.5hr																						
65°C	93+/-3%RH	4hr																						
65~25°C	80~96%RH	2																						
6	Vibration	IEC68-2-6	1. Sine Wave 2. Amplitude:0.75mm 3. Frequency:5~500~5Hz 4. Direction: X, Y, Z 5. Number of Sweep Cycles Per Direction:10 6. Duration: 2 Hours Each Direction																					
7	Mechanical Shock	MIL-STD-202	1).Half -Sine Wave 2).Peak Acceleration:50G 3).Duration:11mS 4).Direction: X,Y,Z,-X,-Y,-Z 5).Number of Shock Per Direction:3																					
8	Free Drop	ISO4180	1) Height: Refer to Specification According to Production weight 2).1Corner,3Edges,6Faces .Total Are 10 Times																					
9	Solderability	JESD22-B102D	1).Precondition:150±5°C,16±0.5Hours 2).Flux Type:ROL1 3).Immersion Flux Time: 5~10 Seconds 4).Solder Temperature:245±5°C 5).Solder Immersion Time:5±0.5 Seconds 6).Solder Immersion/Emersion Speed:25.4±6.4mm/Second																					
10	Accelerated Moisture Resistance---Unbiased Autoclave	JESD22-A102-C	1.Temperature:121°C 2. Humidity: 100% 3. Vapor Pressure: 29.7 Psia or 205KPa 4.Duration:96 hours																					



## 6. Material List: 材料清单

No. 序号	Item 项目	Base Material 基材	Plate 电镀	Rating 等级	Manufacturer 制造商	UL 安规证书	Remarks 备注
1	Transformer Core 磁芯	Mn-Zn 锰锌 Ni-Zn 镍锌	----	----	YST(研鑫)	N/A	
2	Wire 铜线	QPN/180 聚胺脂	----	180°C	SUNTEK (松田)	E234867	
3	Case 胶壳	phenolic moulding powder (电木粉)	----	130°C	SUN HONG (盛宏)	E304685	
4	Varnish 绝缘油	绝缘油1032	----	180°C	KIaweiai (格桑)	E213437	
5	Solder 焊料	SnCu 锡铜	----	----	YIK SHING TAT (亿诚达)	N/A	
6	Flux 助焊剂	Water solubility 水溶性松香	----	----	Tongfang (同方)	N/A	

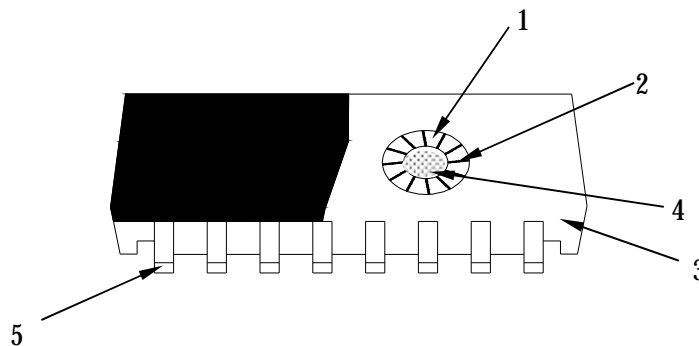



## 6. Material List: 材料清单

No. 序号	Item 项目	Base Material 基材	Plate 电镀	Rating 等级	Manufacturer 制造商	UL 安规证书	Remarks 备注
1	Transformer Core 磁芯	Mn-Zn 锰锌 Ni-Zn 镍锌	----	----	YST(研鑫)	N/A	
2	Wire 铜线	QPN/180 聚胺脂	----	180°C	SUNTEK (松田)	E234867	
3	Case 胶壳	phenolic moulding powder (电木粉)	----	130°C	SUN HONG (盛宏)	E304685	
4	Varnish 绝缘油	绝缘油1032	----	180°C	KIaweiai (格桑)	E213437	
5	Solder 焊料	SnCu 锡铜	----	----	YIK SHING TAT (亿诚达)	N/A	
6	Flux 助焊剂	Water solubility 水溶性松香	----	----	Tongfang (同方)	N/A	

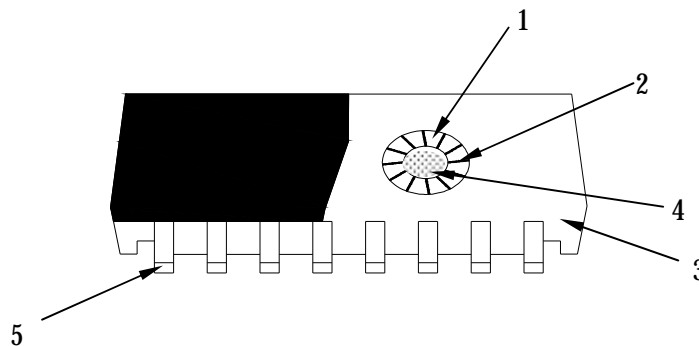



## UL Info.

### WIRE UL



ONLINE CERTIFICATIONS DIRECTORY

OBMW2.E234867  
Magnet Wire - Component

[Page Bottom](#)

### Magnet Wire - Component

[See General Information for Magnet Wire - Component](#)

ZHUHAI SUNTEK WIRE CO LTD  
62 HANQING RD PINGSHATOWN  
JINWAN DISTRICT  
ZHUHAI, GUANGDONG 519055 CHINA

E234867

Mtl Dsg	Mark Dsg	Coat Type		ANSI Type	Temp Class
		BC	OC		
xLEW 180*	(1)	Polyurethane	—	MW82	180
xLEW 155*				MW79#	155
xLEW 130*				MW75#	130
xLEW/NY or QAN/180*	(1)	Polyurethane	Polyamide	MW83	180
xLEW/NY or QAN/155*				MW80#	155
xLEW/NY or QAN/130*				MW28#	130
xSEIW or QZY -w/180*	(1)	Polyesterimide	—	MW77#	180
xSEIW or xPEW/155*	(1)	Polyesterimide	—	MW26#	155
xPEW/130*	(1)	Polyesterimide	—	-#	130

\* May be suffixed by LZ, EL or LZL.

LZ - Signifies magnet wires twisted together; EL - signifies base coated magnet wire laid parallel with top coat applied overall; LZL - signifies base coated magnet wire twisted together and covered with top coat overall.

# This magnet wire may perform better than rating reflects and hence may not be suitable for an insulation system thermal aging program.

x May be prefixed by 0, 1, 2, 3 to indicate coating thickness.

- None ANSI Type.

Marking: Company name and material designation or marked designation on package or reel.

Last Updated on 2008-07-02

[Questions?](#)

[Notice of Disclaimer](#)

[Page Top](#)

Copyright © 2009 Underwriters Laboratories Inc.®

The appearance of a company's name or product in this database does not in itself assure that products so identified have been manufactured under UL's Follow-Up Service. Only those products bearing the UL Mark should be considered to be Listed and covered under UL's Follow-Up Service. Always look for the Mark on the product.

UL permits the reproduction of the material contained in the Online Certification Directory subject to the following conditions: 1. The Guide Information, Designs and/or Listings (files) must be presented in their entirety and in a non-misleading manner.



## Case UL



### ONLINE CERTIFICATIONS DIRECTORY

QMFZ8.E304685

## Plastics Certified for Canada - Component

Additional information regarding this certification can be found in UL's iQ Family of Databases ([iq.ul.com](http://iq.ul.com)).

For additional information concerning the individual material, click on the material designation.

[Page Bottom](#)

## Plastics Certified for Canada - Component

[See General Information for Plastics Certified for Canada - Component](#)

**SUN HONG OPTRONICS LTD**

10 SHENGRONG RD

HUIZHOU HI-TECH ZONE

HUIZHOU, GUANGDONG 516001 CHINA

E304685

Mtl Dsg	Color	Min.	Flame	H	H	H	RTI		C	
		Thk		W	A	V	Elec	Mech	T	
		mm	Class	I	I	A		Imp	Str	I
<b>Bulk Molding Compound "Polyester" (BMC), furnished as bulk.</b>										
3550C	BK	1.5	V-0	-	-	-	105	130	130	-
		3.0	V-0	-	-	-	105	130	130	
BUG-4112C	ALL	1.5	V-0	1	-	-	105	130	130	0
		3.0	V-0	0	-	-	105	130	130	
BUG-4112C-B	ALL	-	-	-	-	-	130	130	130	-
<b>Diallyl Phthalate (DAP), furnished as pellets.</b>										
WH-9100	BK	0.375-0.412	V-0	3	1	-	130	130	130	0
<b>Molded Unsaturated Polyester (UP), furnished as pellets.</b>										
WH-8100	N.C, BK	1.5-1.65	V-0	0	0	-	105	130	130	0
WH-8200	N.C, BK	0.75	V-0	1	0	-	130	130	130	0
		3.0	V-0	0	0	-	130	130	130	

Marking: Company name and material designation, generic polymer identification, color number where appropriate and batch or lot number or date of manufacture on container, wrapper or molded on finished part.

Last Updated on 2010-10-20

[Questions?](#)

[Print this page](#)

[Terms of Use](#)

[Page Top](#)

2012 UL LLC



## Varnish UL

OBOR2.E213437 - (Systems, Electrical Insulation) Varnishes - Component 页码, 1/1



**ONLINE CERTIFICATIONS DIRECTORY**

**OBOR2.E213437**

**(Systems, Electrical Insulation) Varnishes - Component**

Page Bottom

### Varnishes - Component

See General Information for Varnishes - Component

**QUANTPOLY CHEMICAL CORP**  
2 YEONG GONG 5TH RD  
YEONG AN TSIANG  
TAIPEI HSIEN, 828 TAIWAN

E213437

Varnish Desg	ANSI Magnet Wire Type	Varnish Thermal Class C		
		TP	HC	CE
V821XXX	MW75-C	155	180	—
1032XXX	MW75-C	155	130	—
V852xx	MW 35	180	200	—

**Note:** X may be replaced by an alpha numeric code

**Note:** xx may be replaced by an alpha numeric code where the first "x" represents the viscosity and the second "x" represents the solid content.

Marking: Company name or "E213437" and varnish designation on shipping container.

Last Updated on 2006-03-24

[Questions?](#)

[Print this page](#)

[Notice of Disclaimer](#)

[Page Top](#)

Copyright © 2010 Underwriters Laboratories Inc.®

The appearance of a company's name or product in this database does not in itself assure that products so identified have been manufactured under UL's Follow-Up Service. Only those products bearing the UL Mark should be considered to be Listed and covered under UL's Follow-Up Service. Always look for the Mark on the product.

UL permits the reproduction of the material contained in the Online Certification Directory subject to the following conditions: 1. The Guide Information, Designs and/or Listings (files) must be presented in their entirety and in a non-misleading manner, without any manipulation of the data (or drawings). 2. The statement "Reprinted from the Online Certifications Directory with permission from Underwriters Laboratories Inc." must appear adjacent to the extracted material. In addition, the reprinted material must include a copyright notice in the following format: "Copyright © 2010 Underwriters Laboratories Inc.®"

An independent organization working for a safer world with integrity, precision and knowledge.

