

28V, 2A, High Efficiency Synchronous Step-Down Converter in FCTSOT23-6

DESCRIPTION

ETA1476 is a wide input range, high-efficiency and high frequency DC-to-DC step-down switching regulator, capable of delivering up to 2A of output current. With a fixed switching frequency of 500KHz, this current mode PWM controlled converter allows the use of small external components, such as ceramic input and output caps, as well as small inductors. ETA1476 also employs a proprietary control scheme that switches the device into a power save mode during light load, thereby extending the range of high efficiency operation. The IC can stand off input voltage as high as 30V against input voltage surges, making it an ideal solution for industrial applications such as LCD TV, Set Top Box, Portable TV, etc.

ETA1476 is available in FCTSOT23-6 package.

FEATURES

- ◆ Wide Input Range: 4.5V-28V
- ◆ High Efficiency PFM mode at light load
- ◆ Capable of Delivering 2A
- ◆ No External Compensation Needed
- ◆ Current Mode Control
- ◆ Thermal Shutdown and UVLO
- ◆ Excellent Load and Line Transient Response
- ◆ Available in FCTSOT23-6 Package

APPLICATIONS

- ◆ LCD TV
- ◆ Set Top Box
- ◆ Portable TV

TYPICAL APPLICATION

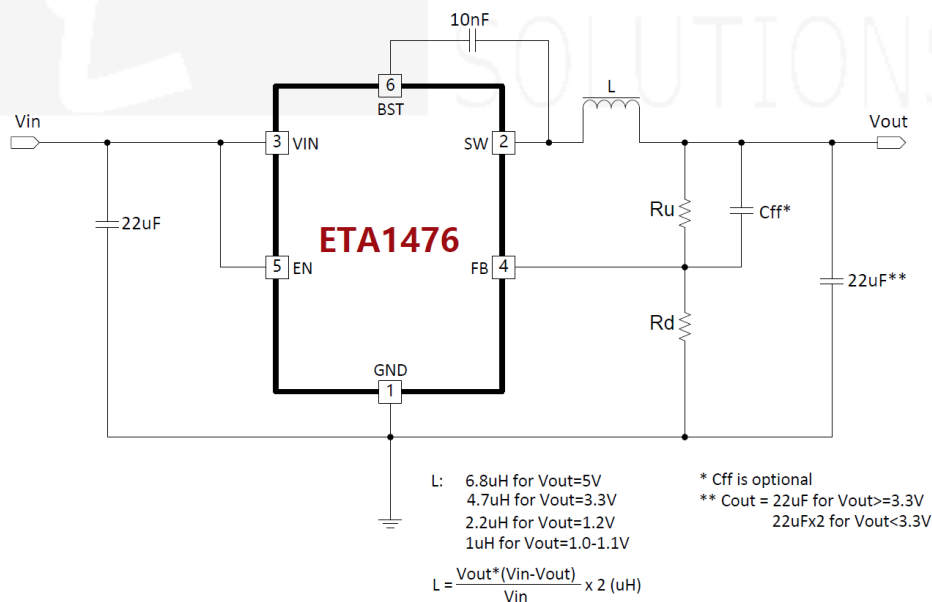

ORDERING INFORMATION

PART No.	PACKAGE	TOP MARK	Pcs/Reel
ETA1476FT2G	FCTSOT23-6	CxYW	3000

PIN CONFIGURATION

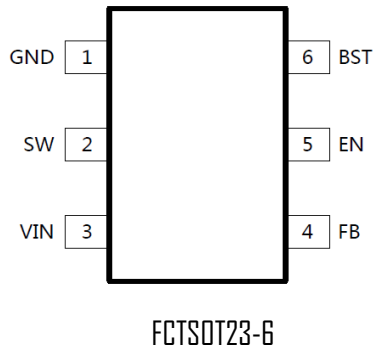

ABSOLUTE MAXIMUM RATINGS

(Note: Exceeding these limits may damage the device. Exposure to absolute maximum rating conditions for long periods may affect device reliability.)

IN,SW,EN Voltage	-0.3V to 30V
BST Voltage	-0.3V to SW+6V
FB Voltage	-0.3V to 6V
Operating Temperature Range	-40°C to 85°C
Storage Temperature Range	-55°C to 150°C
Thermal Resistance	θ_{JA} θ_{JC}
FCTSOT23-6.....	100.....55..... °C/W
Lead Temperature (Soldering 10ssec)	260°C
ESD HBM (Human Body Mode)	2KV
ESD MM (Machine Mode)	200V

ELECTRICAL CHARACTERISTICS

($V_{IN} = 12V$, $V_{OUT} = 3.3V$, unless otherwise specified. Typical values are at $T_A = 25^\circ C$.)

PARAMETER	CONDITIONS	MIN	TYP	MAX	UNIT
Input Voltage Range		4.5		28	V
Input UVLO	Rising, Hysteresis=340mV	4.0	4.24	4.50	V
Input Supply Current	$V_{FB}=0.65V$		640	1050	μA
Input Shutdown Current			7	14	μA
FB Voltage		0.585	0.6	0.615	V
FB Input Current			0	1	μA
Switching Frequency			500		kHz
Maximum Duty Cycle		91	93		%
Short Circuit Hiccup Time	On Time		2		mS
	Off Time		6		mS
FB Hiccup Threshold			0.2		V
High Side Switch On Resistance			155		m Ω
Low Side Switch On Resistance			88		m Ω
High Side Current Limit		3	3.8		A
SW Leakage Current	$I_{N=SW}=12V$			20	μA
EN Rising Threshold		-6%	1.58	+6%	V
EN Falling Threshold		-6%	1.40	-6%	V
EN Input Current	$V_{EN}=2V$		2	6	μA
Thermal Shutdown	Rising, Hysteresis =40°C		150		°C

PIN DESCRIPTION

PIN #	NAME	DESCRIPTION
1	GND	Ground
2	SW	Inductor Connection. Connect an inductor Between SW and the regulator output.
3	VIN	Supply Voltage. Bypass with a 22 μ F ceramic capacitor to GND
4	FB	Feedback Input. Connect an external resistor divider from the output to FB and GND to set V_{OUT}
5	EN	Enable pin for the IC. Drive this pin high to enable the part, low or floating to disable.
6	BST	Bootstrap pin. Connect a 10nF capacitor from this pin to SW

TYPICAL CHARACTERISTICS

(Typical values are at $T_A = 25^\circ\text{C}$ unless otherwise specified.)

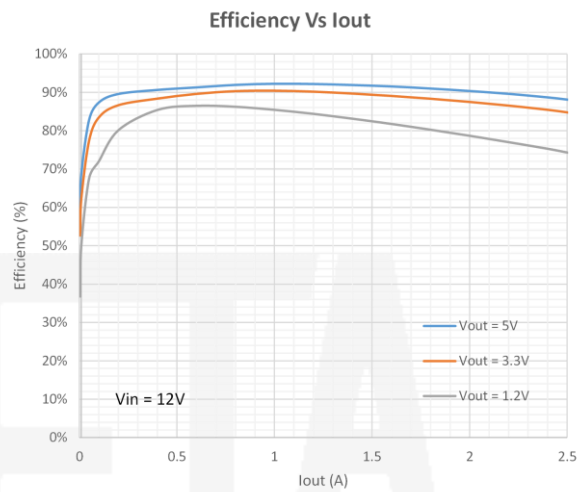
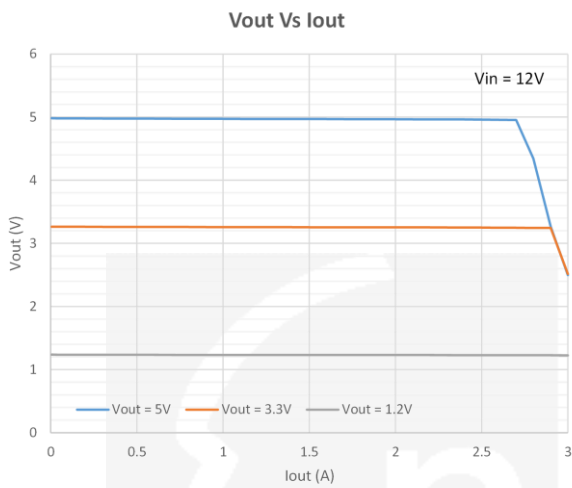

Switching Waveform at Iout = 0A
(Vin=12V, Vout=3.3V)

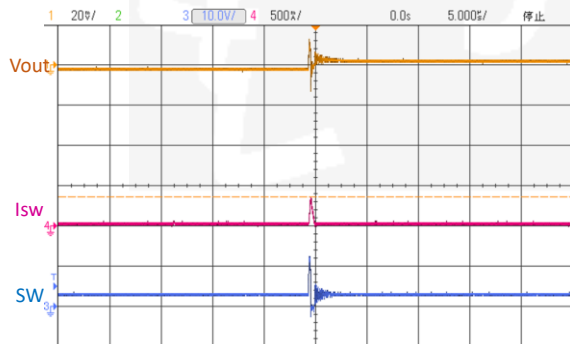

Switching Waveform at Iout = 2A
(Vin=12V, Vout=3.3V)

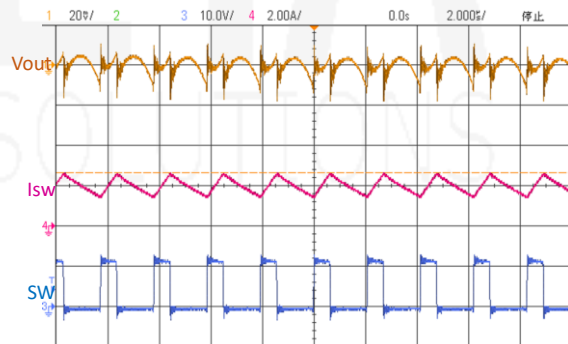

Load Transient Response – Iout Rising Edge 1A/1us
 Vin=12V, Vout=1.1V, L=2.2uH, Cout=22uFx2, Iout 0.3-1.5A

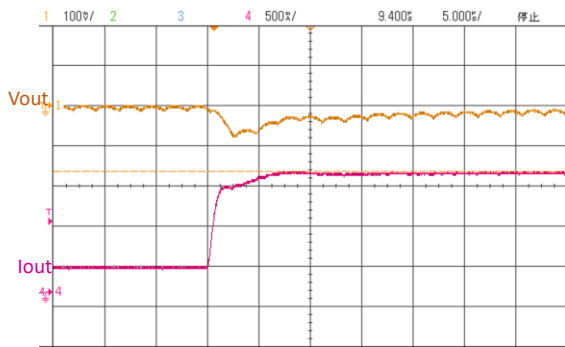

Load Transient Response – Iout Falling Edge 1A/0.2us
 Vin=12V, Vout=1.1V, L=2.2uH, Cout=22uFx2, Iout 1.5-0.3A

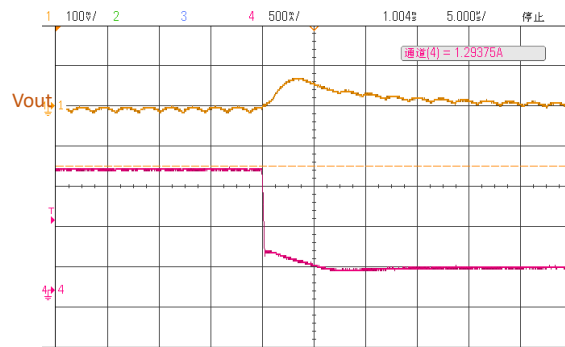

FUNCTIONAL BLOCK DIAGRAM

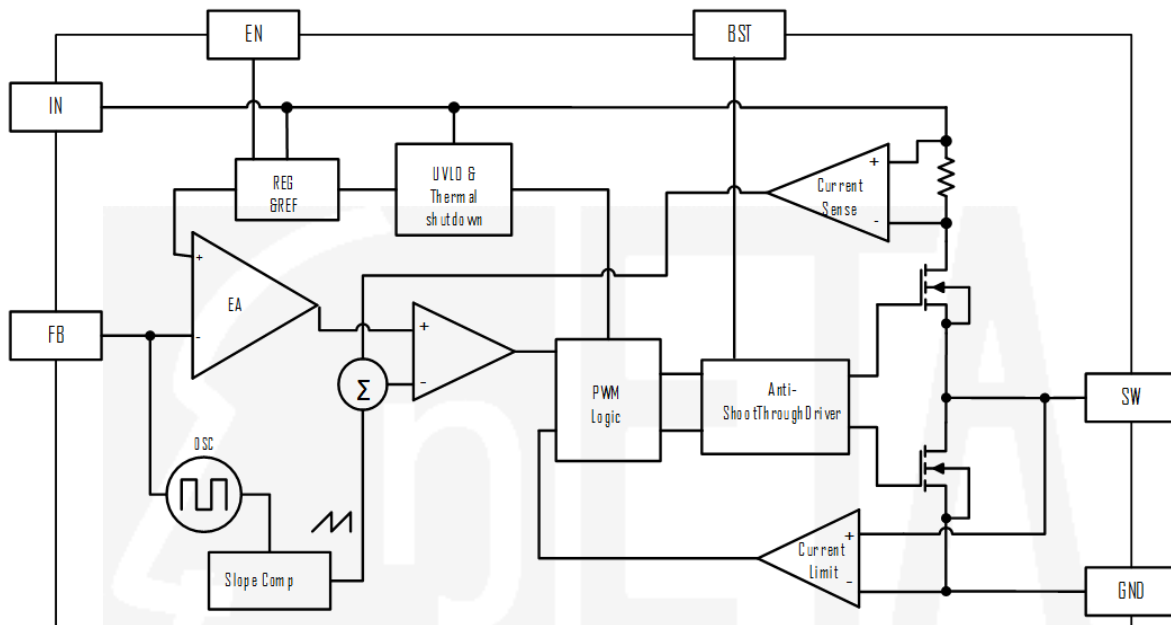

FUNCTIONAL DESCRIPTION

The ETA1476 is a synchronous buck regulator ICs that integrates the PWM control, top and bottom switches on the same die to minimize the switching transition loss and conduction I

The ETA1476 is a wide input range, high efficiency, DC-to-DC step-down switching regulator, capable of delivering up to 2A of output current, integrated with a 155mΩ high side and 88mΩ low side MOSFET. It uses PWM current-mode control scheme. An error amplifier integrates error between the FB signal and the internal reference voltage. The output of the integrator is then compared to the sum of a current-sense signal and the slope compensation ramp. This operation generates a PWM signal that modulates the duty cycle of the power MOSFET to achieve regulation for output voltage.

Light Load Operation

Traditionally, a fixed constant frequency PWM DC-DC regulator always switches even when the output load is small. When energy is shuffling back and forth through the power MOSFET, power is lost due to the finite $R_{ds(on)}$ of the MOSFET and parasitic capacitances. At light load, this loss is prominent and efficiency is therefore very low. ETA1476 employs a proprietary control scheme that improves efficiency in this situation by enabling then device into a power save mode during light load, thereby extending the range of high efficiency operation.

Enable

EN is a digital control pin that turns the ETA1476 on and off. Drive EN High to turn on the regulator, drive it Low to turn it off. An internal $1M\Omega$ resistor from EN pin to GND allows EN to float to shut down the chip. Connecting the EN pin through a pull up resistor or shorted EN to IN will automatically turn on the chip whenever plug in IN.

Over Current Protection and Hiccup

ETA1476 has a cycle-by-cycle over current limit for when the inductor current peak value is over the set current limit threshold. When the output voltage drops until FB falls below UV threshold (0.2V), the ETA1476 will enter hiccup mode. It will turn off the chip immediately for 6mS. After that, it will try to re-starts as normal for 2mS. After 2mS, if FB is still below UV threshold, then the chip enters hiccup mode again. If FB is higher than UV threshold, it will enter the normal mode.

Over-Temperature Protection

Thermal protection disables the output when the junction temperature rises to approximately $150^{\circ}C$, allowing the device to cool down. When the junction temperature cools to approximately $110^{\circ}C$, the output circuitry is again enabled. Depending on power dissipation, thermal resistance, and ambient temperature, the thermal protection circuit may cycle on and off. This cycling limits regulator dissipation, protecting the device from damage as a result of overheating.

APPLICATION INFORMATION

External Output Voltage Setting

In external Output Voltage Setting Version selected, the ETA1476 regulator is programmed using an external resistor divider. The output voltage is calculated using below equation.

$$V_{OUT} = V_{REF} \times \left(1 + \frac{R_u}{R_d}\right)$$

Where: $V_{REF} = 0.6V$ typically (the internal reference voltage)

Resistors R_d has to be between $1k\Omega$ to $20k\Omega$ and thus R_u is calculated by following equation.

$$R_u = \left(\frac{V_{OUT}}{V_{REF}} - 1\right) \times R_d$$

PCB LAYOUT GUIDE

For any high voltage buck, it is always crucial to have input capacitor placed as close to the chip's VIN and GND pin as possible without any via, because the input capacitor is to keep the chip's real input voltage from dropping too much when large switching current is drawn from the input node. A simple illustration of how to place input capacitor is shown below, and it is highly recommended to strictly follow this guide.

Always place input capacitor (Cin) at this place!

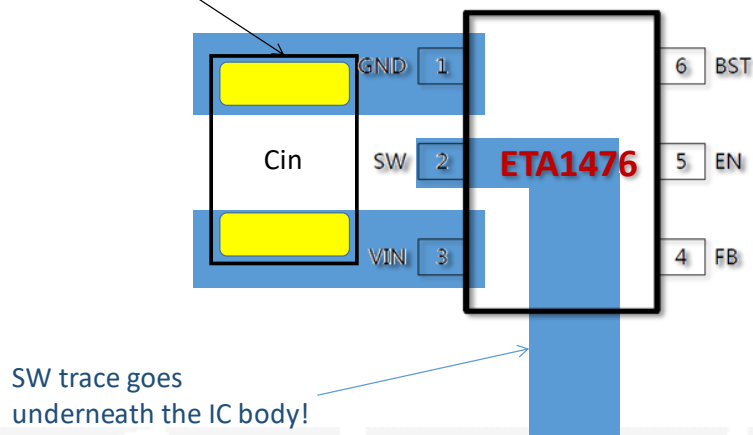

PACKAGE OUTLINE

Package: FCTSOT23-6

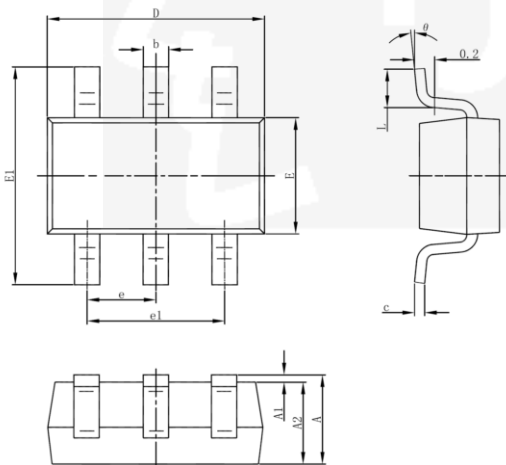

Symbol	Dimensions In Millimeters		Dimensions In Inches	
	Min	Max	Min	Max
A	1.050	1.250	0.041	0.049
A1	0.000	0.100	0.000	0.004
A2	1.050	1.150	0.041	0.045
b	0.300	0.500	0.012	0.020
c	0.100	0.200	0.004	0.008
D	2.820	3.020	0.111	0.119
E	1.500	1.700	0.059	0.067
E1	2.650	2.950	0.104	0.116
e	0.950(BSC)		0.037(BSC)	
e1	1.800	2.000	0.071	0.079
L	0.300	0.600	0.012	0.024
θ	0°	8°	0°	8°