



# 物料承认书 APPROVAL SHEET

RoHS

档案编号:

客户名称:	华秋
Customer Name:	

供应商	东莞市创慧电子有限公司			
公司地址	东莞市谢岗镇金川工业区			
物料名称	铝电解电容器	物料名称	铝电解电容器	
物料编码	CD1102EM221K400T	物料品牌	CH	
物料规格	250V220uF	供方电话	0769-87633398	
物料尺寸	D13X40L	供方传真	0769-87633399	
附件	物料规格书:	<input type="checkbox"/> N <input type="checkbox"/> Y	ROHS检测报告:	<input type="checkbox"/> N <input type="checkbox"/> Y
	样品测试报告:	<input type="checkbox"/> N <input type="checkbox"/> Y	IQC样品:	<input type="checkbox"/> N <input type="checkbox"/> Y
备注	<input type="checkbox"/> 新机型物料 <input type="checkbox"/> 物料变更 <input type="checkbox"/> 增加/变更供应商 <input type="checkbox"/> 其它:			

### 客户确认栏

批准 Approver	审核 Checker	制作 Engineer	盖章

日期:

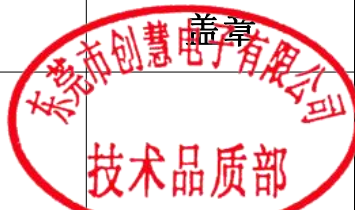
供应商确认栏			
批准 Approver	审核 Checker	制作 Engineer	盖章
刘劲松	魏小容	邓瑶玲	

日期:

2023/8/4

# CD110 Series

## Aluminum Electrolytic Capacitors

Item Name	Rating	Case size
CD1102EM221K400T	250V220uF	D13X40L

### 1. Operating Temp. Range

-40+105°C

### 2. Electrical Characteristics

See Table 1.

【Table 1】

Rated Voltage VDC	Surge Voltage VDC	Nominal Static Capacitance (μF)	Tolerance on Capacitance (%) 20°C 120Hz	Dissipation Factor (tanδ) max 20°C 120Hz	Leakage Current 2min. 20°C (μA)	Permissible Ripple Current (mArms) 105°C 120Hz	Impedance (Ω) 100KHz 20°C
250	300	220	±20%	0.15	1115	700	/

### 3. Dimensions

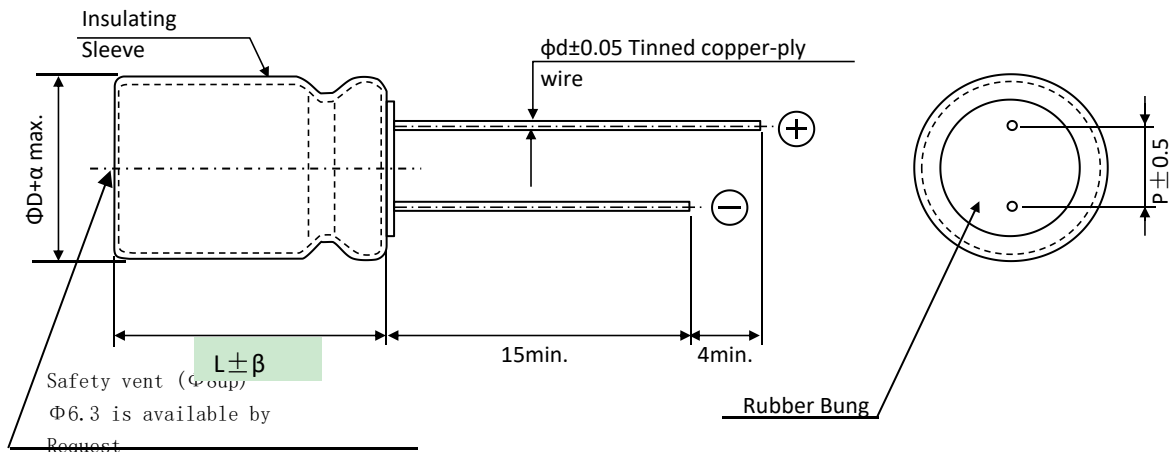

ΦD	α	L	β	Φd	P
13	0.5	40.0	2.0	0.6	5.0

### 4. Marking

Following items are printed with white colour on black colour sleeve

Example of Marking

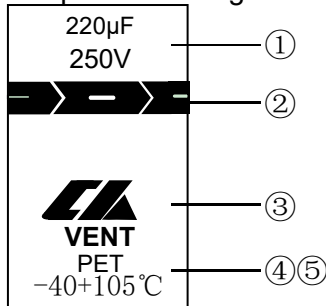

- ① Rated Voltage & Nominal Capacitance
- ② Polarity (negative)
- ③ Trade Mark of CH
- ④ Product Series
- ⑤ Operating Temp. Range

### 5. MULTIPLIER FOR RIPPLE CURRENT

#### ①. Frequency Coefficient

Freq.(Hz)	50Hz	120Hz	1KHz	10KHz	100KHz
Cap(μF)	0.80	1.00	1.36	1.48	1.53

#### ②. Temperature Coefficient

Ambient Temperature(°C)	40	60	70	85	105
Coefficient	2.4	2.1	1.78	1.65	1

## 6. Characteristics

No.	Item	Performance	Test Method																							
1	Leakage Current	$I \leq 1115\mu A$	Protection Resistor: $1000 \pm 10\Omega$ Applied Volt: Rated Voltage Measuring time: 2 minutes																							
2	Static Capacitance	$\pm 20\%$	Measured Frequency: $120\text{Hz} \pm 20\%$ Measured Voltage: $\leq 0.5\text{Vrms}, 1.5 \sim 2.0\text{VDC}$																							
3	Dissipation Factor (tan $\delta$ )	0.15 and Under	Same as condition of Capacitors																							
4	Load Life	<table border="1"> <tr> <td>Leakage Current</td> <td><math>\leq</math> the value specified in Table 1</td> </tr> <tr> <td>Cap. Change</td> <td><math>\leq \pm 20\%</math> of initial value</td> </tr> <tr> <td>Dissipation Factor</td> <td><math>\leq 200\%</math> of value specified in Table 1</td> </tr> <tr> <td>Appearance</td> <td>No remarkable abnormality</td> </tr> </table>	Leakage Current	$\leq$ the value specified in Table 1	Cap. Change	$\leq \pm 20\%$ of initial value	Dissipation Factor	$\leq 200\%$ of value specified in Table 1	Appearance	No remarkable abnormality	The capacitor can work for 2000 H under normal															
Leakage Current	$\leq$ the value specified in Table 1																									
Cap. Change	$\leq \pm 20\%$ of initial value																									
Dissipation Factor	$\leq 200\%$ of value specified in Table 1																									
Appearance	No remarkable abnormality																									
5	Shelf Life	<table border="1"> <tr> <td>Leakage Current</td> <td><math>\leq</math> the value specified in Table 1</td> </tr> <tr> <td>Cap. Change</td> <td><math>\leq \pm 20\%</math> of initial value</td> </tr> <tr> <td>Dissipation Factor</td> <td><math>\leq 200\%</math> of value specified in Table 1</td> </tr> <tr> <td>Appearance</td> <td>No remarkable abnormality</td> </tr> </table>	Leakage Current	$\leq$ the value specified in Table 1	Cap. Change	$\leq \pm 20\%$ of initial value	Dissipation Factor	$\leq 200\%$ of value specified in Table 1	Appearance	No remarkable abnormality	The capacitor can be placed for 1000H under normal conditions															
Leakage Current	$\leq$ the value specified in Table 1																									
Cap. Change	$\leq \pm 20\%$ of initial value																									
Dissipation Factor	$\leq 200\%$ of value specified in Table 1																									
Appearance	No remarkable abnormality																									
6	Terminal Strength	<table border="1"> <tr> <td>Tensile Strength</td> <td>45N {4.5kg}</td> </tr> <tr> <td>Bending Strength</td> <td>25N {2.5kg}</td> </tr> </table>	Tensile Strength	45N {4.5kg}	Bending Strength	25N {2.5kg}	Keeping time Tensile: 1 ~ 5 sec Bending: 30 $\pm$ 5 sec																			
Tensile Strength	45N {4.5kg}																									
Bending Strength	25N {2.5kg}																									
7	Impedance Ratio	<table border="1"> <tr> <td>Z(-25°C) / Z(+20°C)</td> <td>3</td> </tr> <tr> <td>Z(-40°C) / Z(+20°C)</td> <td>-</td> </tr> </table>	Z(-25°C) / Z(+20°C)	3	Z(-40°C) / Z(+20°C)	-																				
Z(-25°C) / Z(+20°C)	3																									
Z(-40°C) / Z(+20°C)	-																									
8	Temperature Characteristics	<table border="1"> <thead> <tr> <th>Stage</th> <th>Item</th> <th>Performance</th> </tr> </thead> <tbody> <tr> <td>2,3</td> <td>Impedance Ratio</td> <td>less than the value mentioned in 6-7</td> </tr> <tr> <td>5</td> <td>Cap. Change</td> <td><math>\leq \pm 25\%</math> against value in stage 4</td> </tr> </tbody> </table> <p>After the capacitor is held at temperature of each stage and reaches temperature stability, measure performance.</p>	Stage	Item	Performance	2,3	Impedance Ratio	less than the value mentioned in 6-7	5	Cap. Change	$\leq \pm 25\%$ against value in stage 4	<table border="1"> <thead> <tr> <th>Stage</th> <th>Test Temp(°C)</th> </tr> </thead> <tbody> <tr> <td>1</td> <td>20<math>\pm</math>2</td> </tr> <tr> <td>2</td> <td>-25<math>\pm</math>3;</td> </tr> <tr> <td>3</td> <td>-40<math>\pm</math>3;</td> </tr> <tr> <td>4</td> <td>20<math>\pm</math>2</td> </tr> <tr> <td>5</td> <td>105<math>\pm</math>2</td> </tr> <tr> <td>6</td> <td>20<math>\pm</math>2</td> </tr> </tbody> </table>	Stage	Test Temp(°C)	1	20 $\pm$ 2	2	-25 $\pm$ 3;	3	-40 $\pm$ 3;	4	20 $\pm$ 2	5	105 $\pm$ 2	6	20 $\pm$ 2
Stage	Item	Performance																								
2,3	Impedance Ratio	less than the value mentioned in 6-7																								
5	Cap. Change	$\leq \pm 25\%$ against value in stage 4																								
Stage	Test Temp(°C)																									
1	20 $\pm$ 2																									
2	-25 $\pm$ 3;																									
3	-40 $\pm$ 3;																									
4	20 $\pm$ 2																									
5	105 $\pm$ 2																									
6	20 $\pm$ 2																									
9	Surge Voltage	<table border="1"> <thead> <tr> <th>Item</th> <th>Performance</th> </tr> </thead> <tbody> <tr> <td>Leakage Current</td> <td><math>\leq</math> the initial specified value</td> </tr> <tr> <td>Cap. Change</td> <td><math>\leq \pm 15\%</math> against value before test</td> </tr> <tr> <td>Dissipation Factor</td> <td><math>\leq</math> the initial specified value</td> </tr> <tr> <td>Appearance</td> <td>No remarkable abnormality</td> </tr> </tbody> </table>	Item	Performance	Leakage Current	$\leq$ the initial specified value	Cap. Change	$\leq \pm 15\%$ against value before test	Dissipation Factor	$\leq$ the initial specified value	Appearance	No remarkable abnormality	Test Temp.: 15 ~ 35°C Test volt.: Surge Volt. Specified in 2 Voltage apply 1,000 times of charge for 30 $\pm$ 5 sec, under frequency of 6 $\pm$ 0.5 sec, and discharge for 5min 30sec.													
Item	Performance																									
Leakage Current	$\leq$ the initial specified value																									
Cap. Change	$\leq \pm 15\%$ against value before test																									
Dissipation Factor	$\leq$ the initial specified value																									
Appearance	No remarkable abnormality																									
10	Vibration Resistance	<table border="1"> <tr> <td>Capacitance</td> <td>Stability required</td> </tr> <tr> <td>Cap. Change</td> <td><math>\leq \pm 5\%</math> of the initial specified value</td> </tr> <tr> <td>Appearance</td> <td>No remarkable abnormality</td> </tr> </table>	Capacitance	Stability required	Cap. Change	$\leq \pm 5\%$ of the initial specified value	Appearance	No remarkable abnormality	Frequency: 10 ~ 55Hz Width of vibration: 1.5mm Direction and duration: X,Y and Z directions, each for 2 hours																	
Capacitance	Stability required																									
Cap. Change	$\leq \pm 5\%$ of the initial specified value																									
Appearance	No remarkable abnormality																									
11	Solderability	3/4 area of surrounding directions of surface should be covered with new solder.	Solder: Sn-Ag, Sn-Cu Type Soldering Temp: 240 $\pm$ 5°C Dipping degree: 2 ~ 2.5mm Flux: Ethanol solution (JIS K8101) or Isopropylalcohol (JIS K8839) solution of Rosin (JIS K5902)																							
12	Resistance to Soldering	<table border="1"> <tr> <td>Leakage Current</td> <td><math>\leq</math> the initial specified value</td> </tr> <tr> <td>Cap. Change</td> <td><math>\leq \pm 15\%</math> against value before test</td> </tr> <tr> <td>Dissipation Factor</td> <td><math>\leq</math> the initial specified value</td> </tr> <tr> <td>Appearance</td> <td>No remarkable abnormality</td> </tr> </table>	Leakage Current	$\leq$ the initial specified value	Cap. Change	$\leq \pm 15\%$ against value before test	Dissipation Factor	$\leq$ the initial specified value	Appearance	No remarkable abnormality	Soldering Temp. 280 $\pm$ 5°C Soldering Time . 10 $\pm$ 1sec.															
Leakage Current	$\leq$ the initial specified value																									
Cap. Change	$\leq \pm 15\%$ against value before test																									
Dissipation Factor	$\leq$ the initial specified value																									
Appearance	No remarkable abnormality																									

## 6-2. Characteristics

No.	Item	Performance	Test Method
13	Resistance to Humidity	Leakage Current	≤ Initial specified value
		Cap. Change	≤ ±15% of initial value
		Dissipation Factor	≤ Initial specified value
		Appearance	No remarkable abnormality
			Test Temp. : 40±2°C Humidity 90~95% Test Time : 500 ± 8 hours After the above condition, restored to normal temp, and then measured.
14	Pressure valve moment characteristics	Pressure valve open safely. There must be nothing ignition or scattering from product.	DC method: Apply an reverse current of 1A to impress the reverse voltage until pressure valve open.
The above data is for reference only, the service life depends on the working environment temperature, continuous working time, current size and many other factors, the actual results may be different.			

## 7. Packing method

Packaging shape, size, quantity

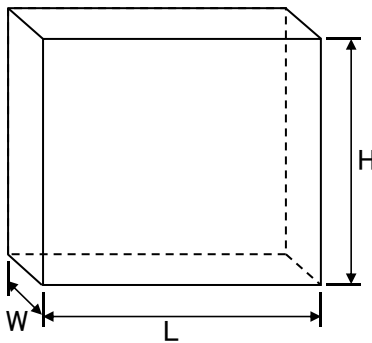

Component size	<b>D13X40L</b>
Quantity per case	<b>PCS</b>
Symbol of box	Y-2
L	480
H	320
W	320

## 8 Related Standards: JIS C 5141

### 9 Marking on packing box

- ① Item name
- ② Series name
- ③ Rated Voltage
- ④ Nominal Static Capacitance
- ⑤ Case size
- ⑥ Lot No.
- ⑦ Quantity

## 10 Soldering

10-1 Soldering by soldering iron

Temperature of iron top : 270~350°C

Operating time : within 3 sec.

10-2 Flow soldering.

Preheat : PCB surface temperature 120°C±5°C

Solder temp.: 260°C±5°C

Solder dipping time: 2~4sec.

## 11 Cleaning of PC board after soldering

Some solvents is acceptable but make sure following condition:

Solvent:

IPA or Alcoholic agent like Pinealpha ST-100S, Cleantrough 750H, 750L, 710M, 750K, or Technocare FRW-14~17

- ① Cleaning should be made by ultrasonic within 5min, at the temperature less then 60°C.
- ② Control of pollution is necessary.
- ③ Keep away from cleaning agent. Please do not store in air-tight container.  
Dry it by hot air, keep the temperature of air less than maximum operating temp.



# 东莞市创慧电子有限公司

DongGuan ChuangHui electronics Co.,Ltd.

## TEST DATA SHEET OF ELECTROLYTIC CAPACITORS (检测数据表)

DATE (日期):	2023/8/4	QUANTITY (数量):	10 PCS
CUSTOMER (客户):	华秋	BRAND/SERIES (商标/系列):	CH CD110
RATINGS (规格):	250V220uF	CASE SIZE (尺寸):	D13X40L
LEAD PITCH (脚距):	5.0 ±0.5mm	LEAD DIA. (引线直径):	0.6 ±0.05mm

Item	Capacitance Tolerance at 120Hz 20°C	Max. Tanδ at 120Hz 20°C	Max. Leakage Current (μA) after 2 min.	Max. Impedance (Ω) at 100KHz 20°C	Max. Ripple Current (mArms) at 120Hz 105 °C	Working Temp. (°C)	Surge Volt. (V)
Spec	±20%	15%	1115.0	/	700	-40+105°C	300

No.	Capcittance (μF)	Tanδ (%)	Leakage Current(μA)	Impedance (Ω)	Remarks
1	192.5	5.2	45.2		
2	193.6	5.1	46.2		
3	194.2	5.3	51.2		
4	194.5	5.4	53.2		
5	193.5	5.2	55.4		
6	193.2	5.3	49.2		
7	193.5	5.1	56.2		
8	192.6	5.2	51.2		
9	193.7	5.4	55.2		
10	194.5	5.3	53.4		
MIN.	192.5	5.1	45.2		
MAX.	194.5	5.4	56.2		
AVE.	193.6	5.3	51.6		
核准	刘劲松	审核	魏小容	制作	邓瑶玲