

P0080SB - P5000SB Series

ROHS

DO-214AA(SMB) @10/700 μ S, 4KV

Thyristor Surge Suppressors (TSS)

Description

P0080SB- P5000SB Series are designed to protect broadband equipment such as modems, line card, CPE and DSL from damaging over-voltage transients.

The series provides a surface mount solution that enables equipment to comply with global regulatory standards.

Features and Benefits

- ◆ Low voltage overshoot
- ◆ Low on-state voltage
- ◆ Does not degrade surge capability after multiple surge events within limit
- ◆ Fails short circuit when surged in excess of ratings
- ◆ Low Capacitance

Applicable Global Standards

- ◆ TIA-968-A
- ◆ ITU K.20/21 Enhanced level
- ◆ ITU K.20/21 Basic Level
- ◆ GR 1089 Inter building
- ◆ IEC 6100-4-5
- ◆ YD/T 1082
- ◆ YD/T 993
- ◆ YD/T 950

Electrical Parameters

Parameter	Definition
I_S	Switching Current - maximum current required to switch to on state
I_{DRM}	Leakage Current - maximum peak off-state current measured at V_{DRM}
I_H	Holding Current - minimum current required to maintain on state
I_T	On-state Current - maximum rated continuous on-state current
V_S	Switching Voltage - maximum voltage prior to switching to on state
V_{DRM}	Peak Off-state Voltage - maximum voltage that can be applied while maintaining off state
V_T	On-state Voltage - maximum voltage measured at rated on-state current
C_0	Off-state Capacitance - typical capacitance measured in off state



www.unsemi.com.tw

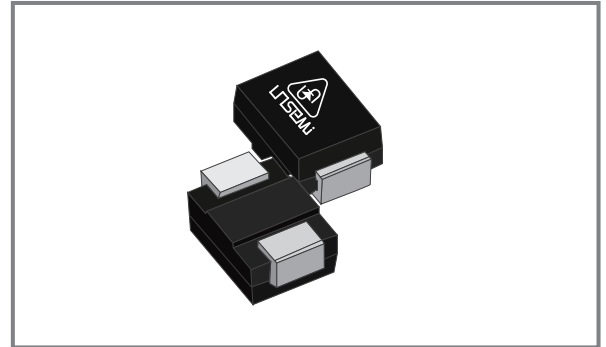

Schematic Symbol

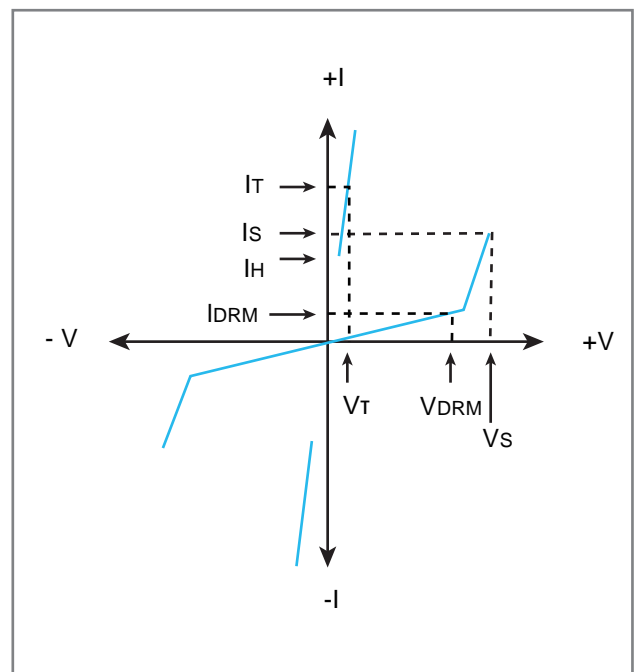

Electrical Characteristics

Part Number	Marking	V_{DRM} @ $I_{DRM}=5\mu A$	I_{DRM}	V_s @100V/ μ S	I_s	V_T @ $I_T=2.2A$	I_T	I_H	C_o @1MHz
		VMin.	μ AMax.	VMax.	mAMax.	VMax.	AMax.	mAMin.	pFMax.
P0080SB	P008B	6	5	25	800	4	2.2	50	70
P0300SB	P03B	25	5	40	800	4	2.2	50	70
P0640SB	P06B	58	5	77	800	4	2.2	150	60
P0720SB	P07B	65	5	88	800	4	2.2	150	60
P0900SB	P09B	75	5	98	800	4	2.2	150	55
P1100SB	P11B	90	5	130	800	4	2.2	150	55
P1300SB	P13B	120	5	160	800	4	2.2	150	55
P1500SB	P15B	140	5	180	800	4	2.2	150	60
P1800SB	P18B	170	5	220	800	4	2.2	150	60
P2000SB	P20B	180	5	220	800	4	2.2	150	60
P2300SB	P23B	190	5	260	800	4	2.2	150	55
P2600SB	P26B	220	5	300	800	4	2.2	150	50
P3100SB	P31B	275	5	350	800	4	2.2	150	45
P3500SB	P35B	320	5	400	800	4	2.2	150	40
P3800SB	P38B	360	5	460	800	4	2.2	150	30
P4200SB	P42B	400	5	520	800	4	2.2	150	30
P4500SB	P45B	420	5	540	800	4	2.2	150	30
P5000SB	P50B	440	5	600	800	4	2.2	150	30

Notes:

- Absolute maximum ratings measured at TA= 25°C (unless otherwise noted).
- Devices are bi-directional.

Surge Ratings

Series	2/10 μ S ¹	8/20 μ S ¹	10/560 μ S ¹	10/560 μ S ¹	10/1000 μ S ¹	5/320 μ S ¹	I_{TSM} 50/60Hz	di/dt
	2/10 μ S ²	1.2/50 μ S ²	10/560 μ S ²	10/560 μ S ²	10/1000 μ S ²	10/700 μ S ²		
	A min	A min	A min	A min	A min	A min	A min	Amps/ μ s max
B	250	250	250	200	80	100	30	500

Notes:

- Current waveform in μ s
 - Voltage waveform in μ s
- Peak pulse current rating (IPP) is repetitive and guaranteed for the life of the product.
 - IPP ratings applicable over temperature range of -40°C to +85°C
 - The device must initially be in thermal equilibrium with -40°C < TJ < +150°C

Thermal Considerations

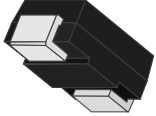
Package	Symbol	Parameter	Value	Unit
DO-214AA 	T _J	Operating Junction Temperature Range	- 40 to +150	°C
	T _s	Storage Temperature Range	- 40 to +150	°C
	R _{θJA}	Thermal Resistance: Junction to Ambient	90	°C/W

Characteristic Curves

Figure 1 - V- I Characteristics

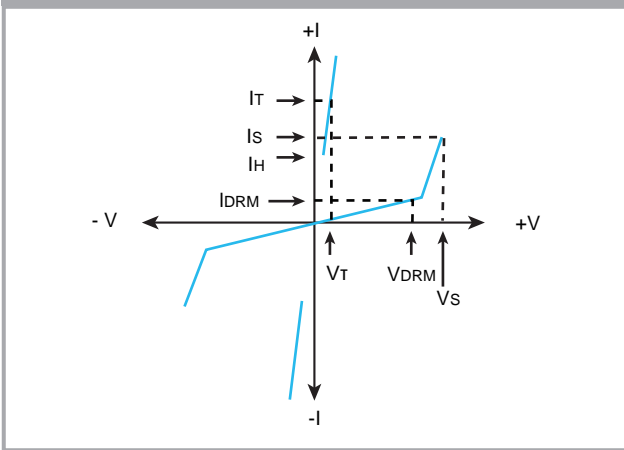

Figure 2 - tr x td Pulse Waveform

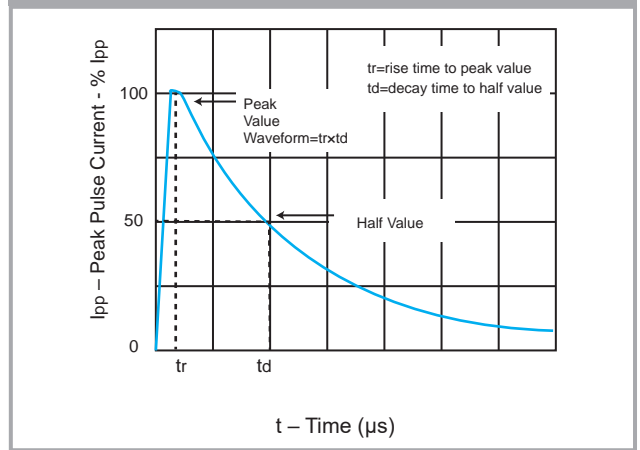

Figure 3 - Normalized VS Change Versus Junction Temperature

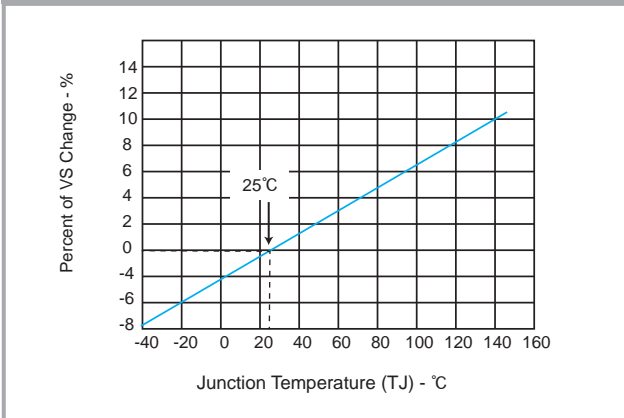
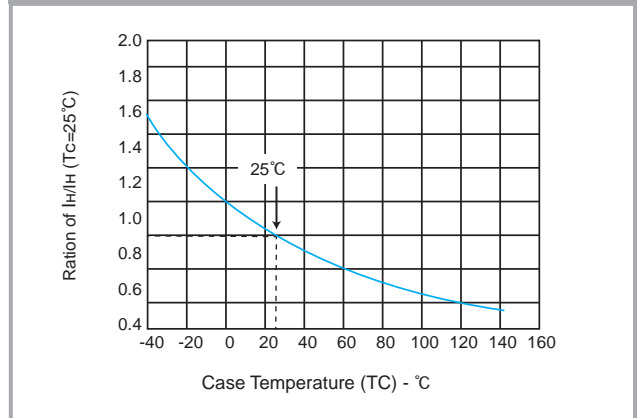

Figure 4 - Normalized DC Holding Current Versus Case Temperature



Environmental Specifications

High Temp Voltage Blocking	80% Rated VDRM (VAC Peak) +125°C or +150°C, Lead Material Copper Alloy High Temp Voltage Blocking 504 or 1008 hrs. MIL-STD-750 (Method 1040) JEDEC, JESD22-A-101
Temp Cying	-65°C to +150°C, 15 min. dwell, 10 up to 100 cycles.MIL-STD-750 (Method 1051) EIA/JEDEC, JESD22-A104
Biased Temp & Humidity	52 VDC (+85°C) 85%RH, 504 up to 1008 hrs. EIA/ JEDEC, JESD22-A-101
High Temp Storage	+150°C 1008 hrs. MIL-STD-750 (Method 1031) JEDEC, JESD22-A-101
Low Temp Storage	-65°C, 1008 hrs.
Thermal Shock	0°C to +100°C, 5 min. dwell, 10 sec. transfer, Thermal Shock 10 cycles. MIL-STD-750 (Method 1056) JEDEC, JESD22-A-106
Autoclave (Pressure Cooker Test)	+121°C, 100%RH, 2atm, 24 up to 168 hrs. EIA/Cooker Test) JEDEC, JESD22-A-102
Resistance to Solder Heat	+260°C, 30 secs. MIL-STD-750 (Method 2031
Moisture Sensitivity Level	85%RH, +85°C, 168 hrs., 3 reflow cycles Level (+260°C Peak). JEDEC-J-STD-020, Level 1

Physical Specifications

Lead Material	Copper Alloy
Terminal Finish	100% Matte-Tin Plated
Body Material	UL recognized epoxy meeting flammability classification 94V-0

Soldering Parameters

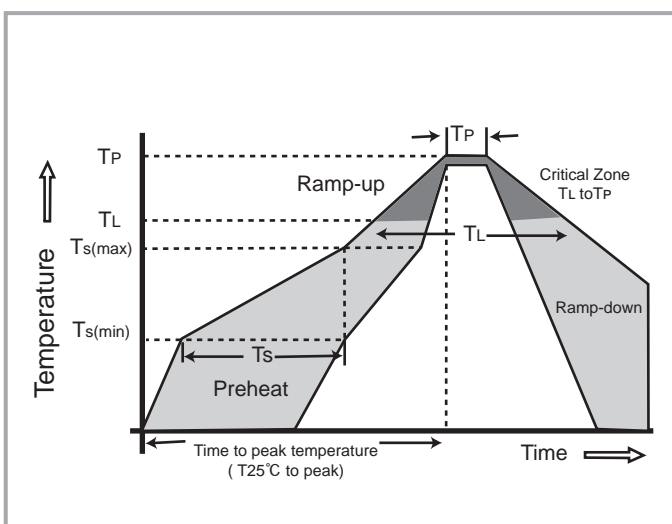

Reflow Condition		Lead-free assembly
Pre Heat	-Temperature Min (Ts(min))	+150°C
	-Temperature Max (Ts(max))	+200°C
	- Time (min to max) (Ts)	60 -180 Seconds
Average ramp up rate (Liquidus Temp TL) to peak		3°C/Second max
Ts(max) to TL - Ramp-up Rate		5°C/Second max
Reflow	- Temperature (TL) (Liquidus)	217°C
	- Time (min to max) (Ts)	60 -150 Seconds
Peak Temperature (TP)		260 +0/-5°C
Time within 5°C of actual peak Temperature (TP)		30 Seconds Max
Ramp-down Rate		6°C/Second Max
Time 25°C to peak Temperature (TP)		8 minutes Max
Do not exceed		+260°C

Part Numbering

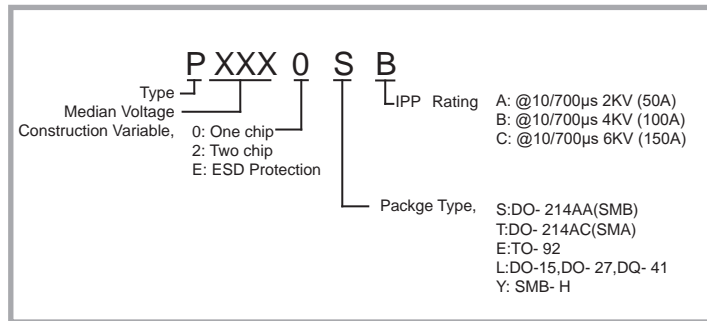

Part Marking

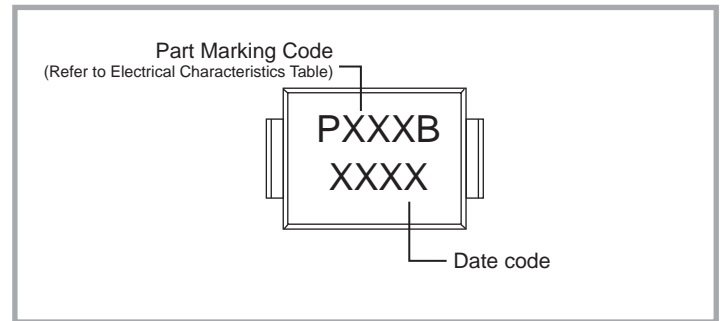

Dimensions DO-214AA

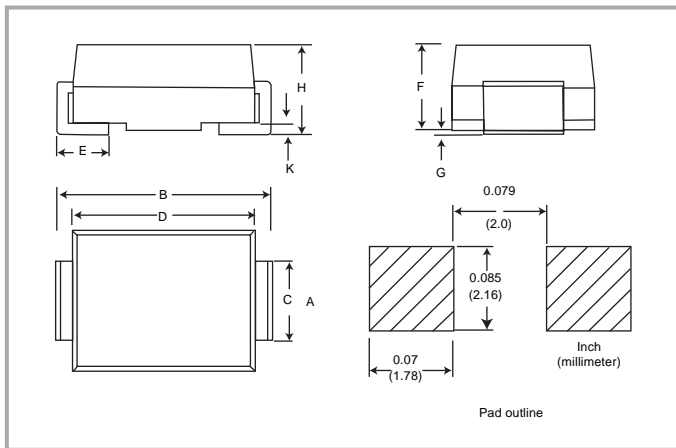

Dimensions	Inches		Millimeters	
	Min	Max	Min	Max
A	0.130	0.156	3.30	3.95
B	0.201	0.220	5.10	5.60
C	0.077	0.087	1.95	2.20
D	0.159	0.181	4.05	4.60
E	0.030	0.063	0.76	1.60
F	0.076	0.096	1.90	2.45
G	0.002	0.008	0.05	0.20
H	0.077	0.104	1.95	2.65
K	0.006	0.016	0.15	0.41

Packaging

Part Number	Component Package	Quantity	Packaging Option	Packaging Specification
Pxxx0SB	DO-214AA	2500	Tape & Reel -12mm/13"tape	EIA -481 - D

Tape and Reel Specifications

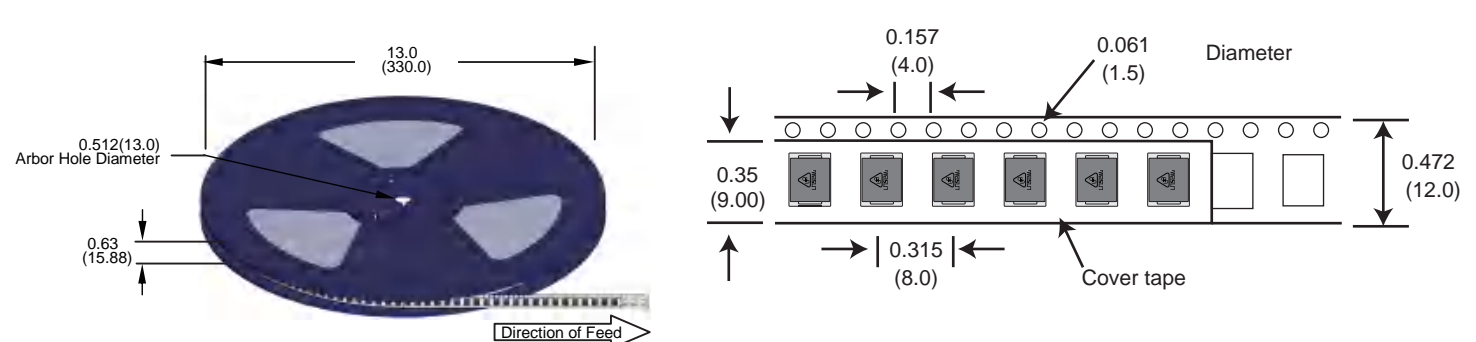

Disclaimer

UNSEMI RESERVES THE RIGHT TO MAKE CHANGE ON OUR PRODUCTS , PRODUCTS SPECIFICATION AND DATA WITHOUT NOTICE TO IMPROVE RELIABILITY, FUNCTION OR DESIGN OR OTHERWISE.

UN SEMICONDUCTOR LIMITED its affiliates, agents, and employees, and all persons acting on its or their behalf (collectively, "UNSEMI") does not give any representations or warranties for any errors, inaccuracies or incompleteness contained in any datasheet or in any other disclosure relating to any product.

In no event shall UNSEMI be liable for any indirect, incidental, punitive, special or consequential damages (including any and all implied warranties, warranties of fitness for particular purpose, non-infringement and merchantability.) whether or not such damages are based on tort (including negligence), warranty, breach of contract or any other legal theory.

Statements regarding the suitability of products for certain types of applications are based on UNSEMI knowledge of typical requirements that are often placed on UNSEMI products in generic applications. Such statements are not binding, statements about the suitability of products for a particular application. It is the customer's responsibility to validate that a particular product with the properties described in the product specification is suitable for use in a particular application. Parameters provided in datasheets or specifications may vary in different applications and performance may vary over time. All operating parameters, including typical parameters, must be validated for each customer application by the customer's technical experts. Product specifications do not expand or otherwise modify UNSEMI's terms and conditions of purchase, including but not limited to the warranty expressed therein.

Unless otherwise agreed in writing, UNSEMI product is not designed, authorized or warranted to be suitable for use in medical life-saving, or life-sustaining application , nor in applications where failure or malfunction of a UNSEMI product can reasonably be expected to result in personal injury, death or severe property or environmental damage. UNSEMI and its suppliers accept no liability for inclusion or use of UNSEMI products in such equipment or applications and therefore such inclusion and/or use is at the customer's own risk.

All referenced brands, product names, service names and trademarks are the property of their respective owners.