

REVISION		RECORD	
REV.	CONTENT	MOD.	DATE
△	初版发行	ARKINE	

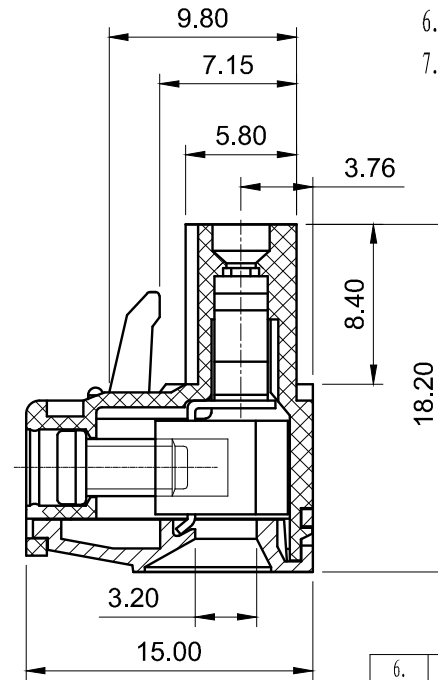
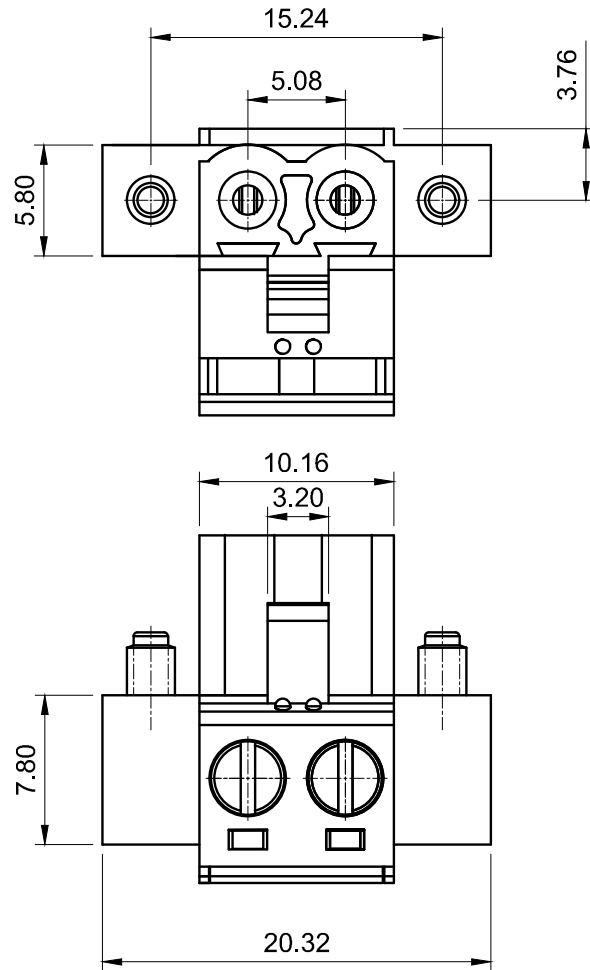

NOTES:

1. Voltage Rating: 300V, Current Rating: 15A
2. PITCH: 5.08mm
3. Insulation Withstands Voltage: AC2500V/min
4. Insulation Resistance: 500MΩ or more at DC500V
5. Using Temperature Range: -40℃ ~ +105℃
6. Suitable Electric Wire: 28-12AWG
7. Screw Torque Value: 0.5 N.m

技术要求:

1. 额定电压: 300V, 额定电流: 15A
2. 间距: 5.08mm
3. 耐压值: AC2500V/min
4. 绝缘阻抗: 500MΩ
5. 使用条件: -40℃ ~ +105℃
6. 适用线规: 28-12AWG
7. 螺丝扭力: 0.5 N.m

	pitch dimension			Nominal dimension					— ▧ ⌒
	over 0 to 6	over 6 to 10	over 10 to 24	over 0 to 30	over 30 to 60	over 60 to 100	over 100 to 150	over 150	
variable range	0	6	10	0	30	60	100	150	—
Tolerance	±0.1	±0.15	±0.25	±0.2	±0.3	±0.5	±0.7	±1.0	0.05/10

6.	LC1-耳朵螺丝	SPOYA255302V	2	碳钢	三价铬钝化彩锌
5.	LC1-5.08-夹子	1001B0001AV	2	磷青铜	镀镍
4.	LC1-5.08-铜方块	F1A0BLC5083V	2	黄铜	镀镍
3.	LC1-5.08螺丝	SPOYA305302V	2	碳钢	三价铬钝化彩锌
2.	LC1-5.08盖子	1001C4002AV	1	PA66-V0	
1.	LC1M-5.08本体	1001M4002AV	1	PA66-V0	
NO.	NAME OF PART	NO. OF PART	Q' TY	MATERIAL	NOTES
DES.	ARKINE	DATE	2010/5/24	UNITS	MM
CHK.		DATE		SIZE	A4
APP.		DATE		SCALE	1:1
				DWG NO.	SP-1-1001M01
				REV:	V0
				TITLE	LC1M-5.08-2P-1Y-00A LC1M-5.08-成品