

1.CONFIGURATION & DIMENSION: m/m

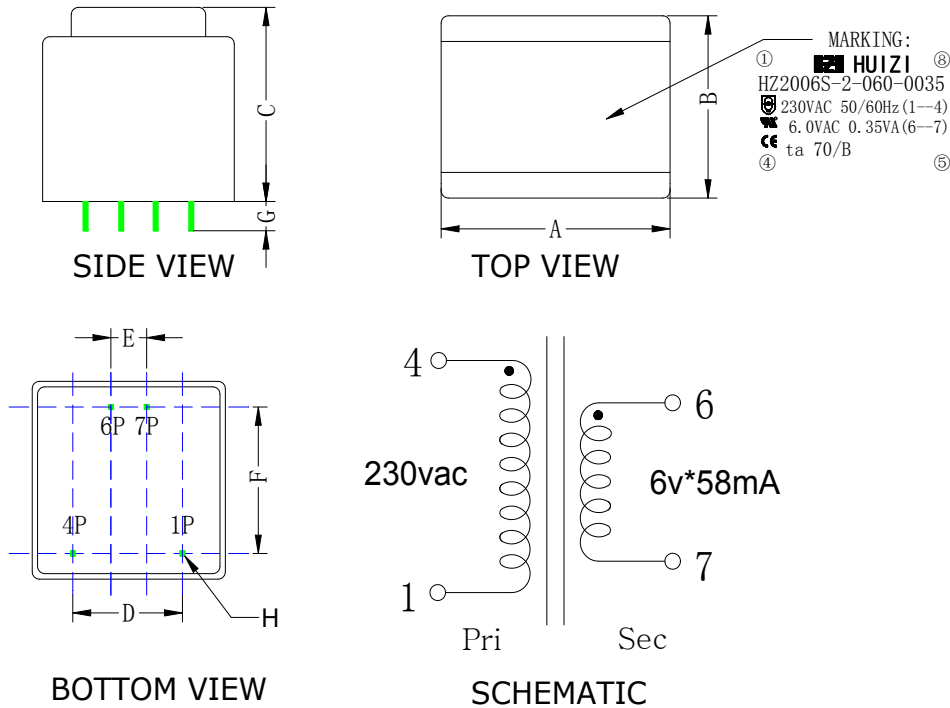

A	B	C	D	E	F	G	H
23.0±0.5	22.0±0.5	15.5±0.5	15.0±0.5	5.0±0.3	15.0±0.5	3.5 ±0.5	□0.54±0.10

2.ELECTRONIC CHARACTER:

Input Power No Load(Po)	Input Power Load(Pi)	Pri Current No Load(I10)	Out Pin	Sec Voltage No Load(Vo)	Sec Voltage(Vi)	Sec Current (Ii)	Output Power (VA)
≤1.1VA	≤1.3VA	≤10.0mA	6--7	10.5V±10%	6.0V±10%	58.0mA	0.35 VA

3.INSULATION RESISTANCE:

THE INSULATION RESISTANCE BETWEEN COIL TO COIL AND COIL TO CORE IS OVER 100MΩ AT DC 500V.

4.DIELECTRIC RESISTANCE:

A.3750V AC 50Hz 5mA BETWEEN PRI TO SEC FOR 60 SEC.

5.MATERIAL LIST:

NO.	ITEM	MATERIAL	MANUFACTURER	UL
1	CORE	M6	JIANGYIN HENGTONG ELECTRICAL COMPANY LIMITED	
2	BOBBIN	PBT/4830	CHANG CHUN PLASTICS CO LTD OR EQUIVALENT	E59481
3	ENCLOSURE	PA66/A2FG5F	NINGBO WEINING ENGINEERING PLASTICS CO LTD OR EQUIVALENT	E256549
4	WIRE	MW-79C	GUANGDONG RONSEN SUPER MICRO-WIRE OR EQUIVALENT	E164502
		MW-79	BAIYIN YIZHI CHANGTONG SUPER OR EQUIVALENT	E363385
5	EPOXY	3300A/B	DONGGUAN EATTO ELECTRONIC OR EQUIVALENT	E218090
6	TAPE	JY-233*	JINGJIANG JINGYANG INSULATING PRODUCT CO LTD	E309872

6.efficiency : ≥30%



SPECIFICATION FOR APPROVAL

PART NO	PART NAME	DATE		PAGE
HZ2006S-2-060-0035	EE20-6.1	2023-5-10		1/1
CHANGSHA HUIZHI ELECTRONICS TECH CO.,LTD TEL:0731-88050299 FAX:0731-88050291 E-MAIL: wit999@163.com http://www.cshzdz.com		APP.	CHECK	DRAWN
		CHENJIANHUI	WENILIXING	CHENKAI