

2840-801

DWG. NO.

REV	ECN ECO	REVISION	APRVD. BY	DATE
A	80860	INITIAL RELEASE	MB	12/23/13
B	93868	ADDED CAVITY NUMBER	MRD	04/03/24
APPROVAL SIGNATURES ON FILE				

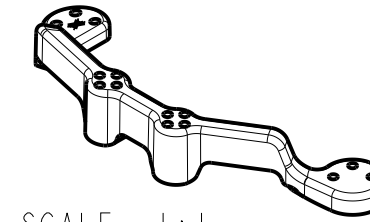
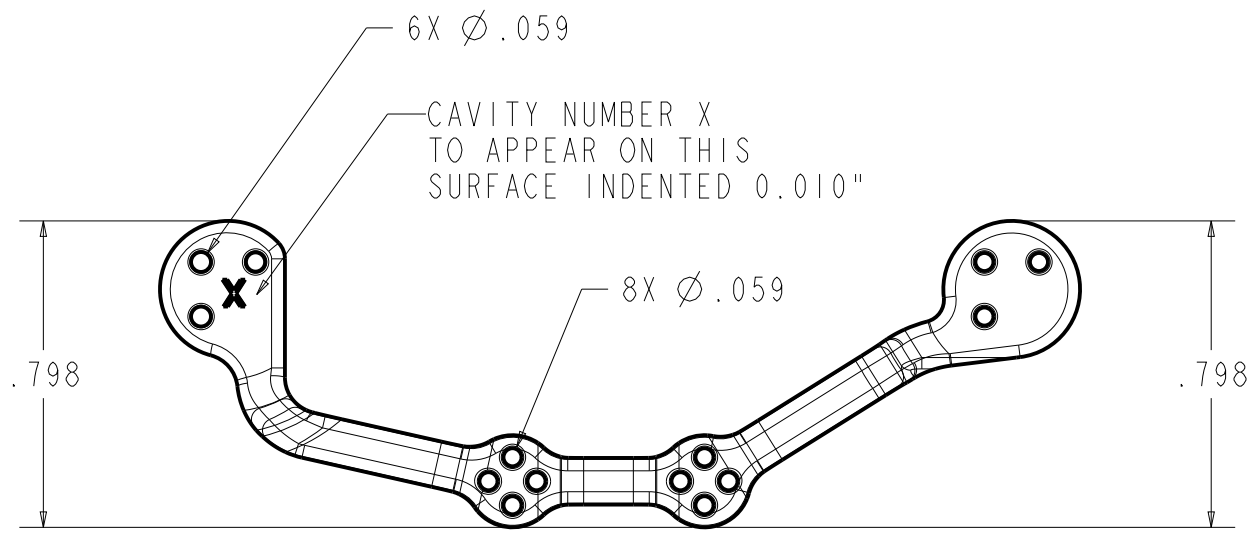

SCALE 1:1

NOTES:

- MATERIAL:  
ABS.  
COLOR : NATURAL
- FINISH: B-3
- VOLUME: 0.079 ^3
- WEIGHT = 1.5 GR
- PART TO BE FREE OF DIRT, GREASE, OIL OR ANY FOREIGN MATERIAL

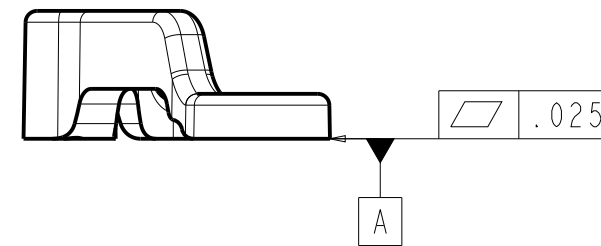
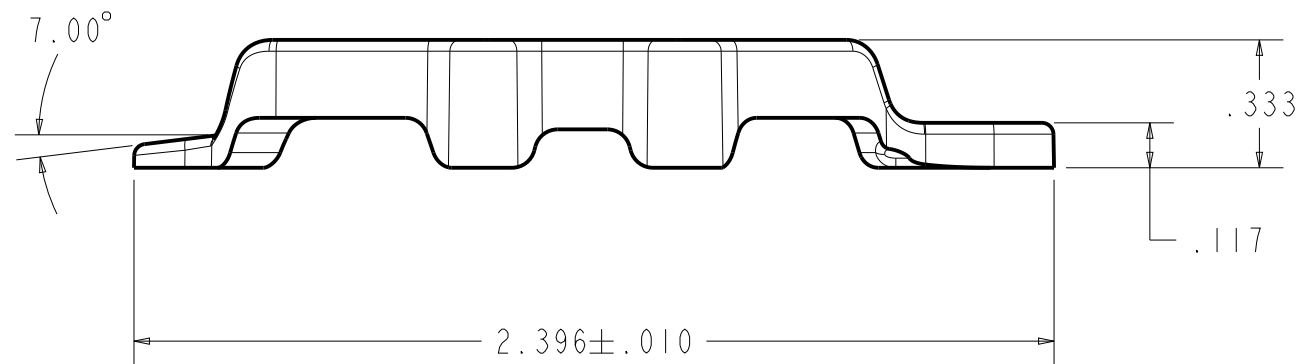

INTERPRET DRAWING PER ASME Y14.100 UNLESS OTHERWISE SPECIFIED DIMENSIONS ARE IN INCHES		<b>TITLE: SENSOR BRIDGE:AMS ACTIVITY COUNTER</b> STATE: <b>Development</b>	
THIRD ANGLE PROJECTION		<b>CONFIDENTIAL</b> ©2012 GOJO Industries, Inc. All Rights Reserved	
		THIS DRAWING IS THE PROPERTY OF <b>GOJO INDUSTRIES, INC.</b> <small>ONE GOJO PLAZA, SUITE 500 AKRON, OH 44311 AND IS LOANED UPON CONDITION THAT IT IS NOT TO BE REPRODUCED OR COPIED IN WHOLE OR PART, OR USED FOR FURNISHING INFORMATION TO OTHERS OR FOR ANY OTHER PURPOSE DETRIMENTAL TO THE INTEREST OF GOJO INDUSTRIES, INC. AND WILL BE RETURNED UPON REQUEST</small>	
TOLERANCES: DECIMALS: X.X = ±0.1 .X.XX = ±0.01 .X.XXX = ±0.005 FRACTIONS: X/XX = ±1/32 ANGLES: X.X = ±0.5 X.XX = ±0.50		DRAWN BY: L.THOMAS DATE: 03/20/12 CHKD BY: B.LIGHTNER DATE: 03/20/12	SCALE 2:1 SHEET   of   DO NOT SCALE DWG. NO. <b>2840-801</b> REV. <b>B</b>