



REV.	ECN NO.	REVISED	DATE

## NOTE:

## 1.MATERIAL:

a.HOUSING:LCP

b.CONTACT:PHOSPHOR BRONZE

(SURFACE PLATING:Sn100u"-120u")

## 2.ELECTRIC:

a.CONTACT RESISTANCE: 30 MILLIOHMS MAX

b.INSULATION RESISTANCE: 1000 MEGA OHMS MIN

c.DIELECTNIC VOLTAGE: 500V AC ONE SEC LEVEL

d.OPERATING TEMPERATURE: -25°C~ +85°C

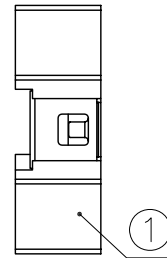
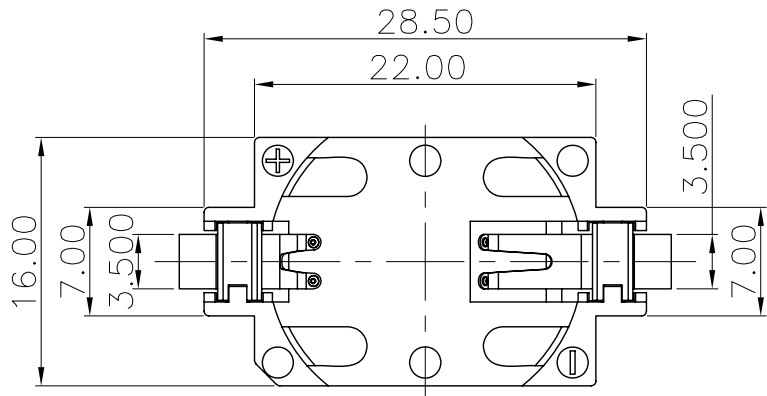

## ORDERING INFORMATION

BS-06-B\*\*\*001

电池座系列

BS-06系列

SMT 180° TYPE

PLATING:

A-Au1U"

J-Ni100U"~120U"

K-Sn100U"~120U"

MATERIAL:

1A-PBT BLACK

1B-PA66 BLACK

2A-PPA BROWN

2B-PPA BLACK

3A-PPS BROWN

3B-PPS BLACK

4A-LCP WHITE

4B-LCP BLACK

5A-PA6T WHITE

5B-PA6T BLACK

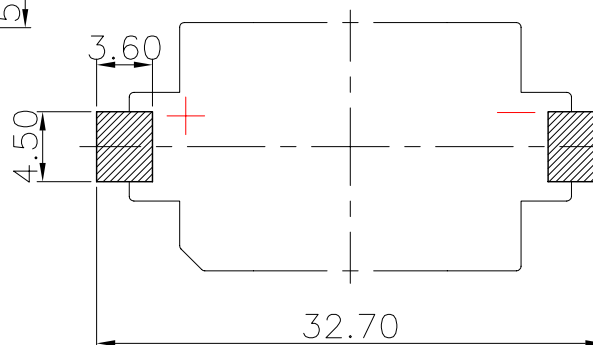
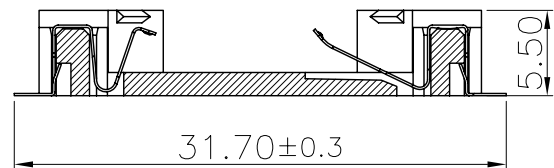
PCB Layout Diagram  
Top View

工程部

2017-07-11

ZW DANG

NO.	PART NAME	Q'TY	MATERIAL	PLATING & COLOR
3	TERMINAL(-)	1	PHOSPHOR BRONZE, T=0.15mm	Sn Plating
2	TERMINAL(+)	1	PHOSPHOR BRONZE, T=0.15mm	Sn Plating
1	HOUSING	1	LCP	WHITE

UNLESS OTHERWISE  
SPECIFIED TOLERANCES

DECIMALS:	ANGLES:
X :±0.30	X :±1°
X.X :±0.25	X.X :±0.5°
X.XX :±0.20	
X.XXX :±0.10	

WEIGHT: 1.49g

SHEET 1 OF 1

迈洛克实业有限公司  
SHENZHEN M&LAK INDUSTRY CO., LTD

DSND YangFeng

DATE 2017-07-11

TITLE: BS-2032-6 Sn SMT

CHKD ZhouRuicai

DATE 2017-07-11

APVD XueShunyong

DATE 2017-07-11

PART NO.: BS-06-B4AK001

SCALE: 2:1

SIZE: A4

VIEW:

UNIT: mm

REV.: A/0

OBJECT: MY

DRAW NO.:MY-CP-0013