

REVISION RECORD				
REV	ECN	DESCRIPTION	DRFT	DATE
AO		NEW		21.08.16

NOTES1:

UL Standard

1. Rated voltage/current : 150V / 8A
2. Withstanding voltage : AC1500V/1Min.
3. Wire range : 26~16AWG

IEC Standard

1. Pollution degree	2
Overvoltage category	III
Rate impulse voltage(KV)	2.5KV
Rate voltage(V)	160V
Rate current(A)	8A

NOTES2:

1. Dimension shall be interpreted per ASME Y14.5-2009
2. Pitch : 3.5mm, Poles : N=04~48P(Total)
3. Stripping length : 9-10mm
4. Operating temperature: -40°C~+105°C
5. Unimensioned tolerances:

Pitch range in mm		Nominal dimension range in mm							
To	Over To	To	Over To	To	Over To	To	Over To	0.1/10	
6	10	24	30	60	100	150	150		
±0.15	±0.20	±0.30	±0.30	±0.50	±0.70	±1.00	±1.30	±2'	

6. RoHS Compliance

Ordering Information

JL15EDGKNHM - 350 XX X XX

Pitch 350=3.5PH
 No. of pins 2*2P~2*24P
 02=2*2P
 03=2*3P
 04=2*4P
 ...
 Housing Color B=Black (Convention)
 G=Green
 U=Blue
 R=Red
 W=White
 Y=Yellow
 O=Orange
 E=Grey
 Serial code

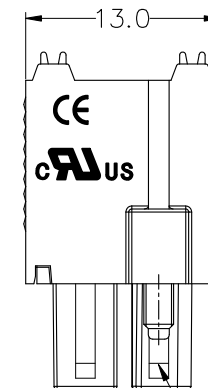
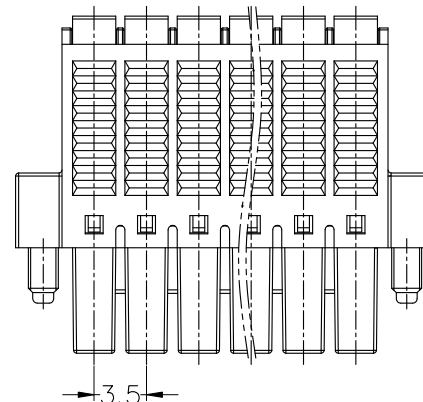
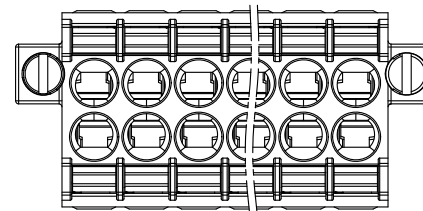
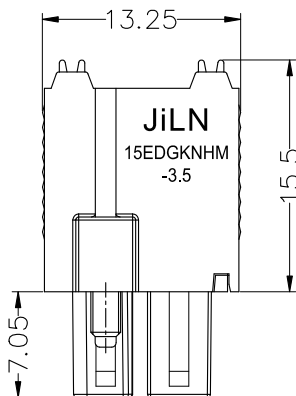

2*2P-2*6P加筋条

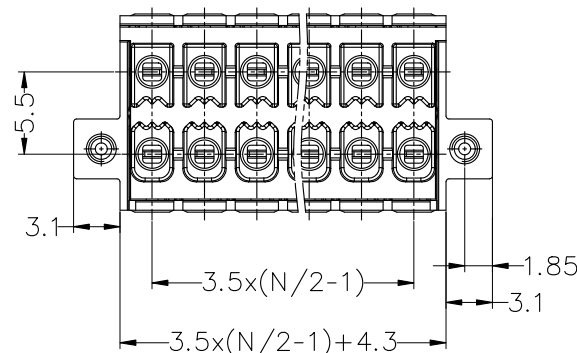

5	Screw	SWRCH	/
4	Shrapnel	SUS 301	/
3	Handle	POM	/
2	Contact	Copper alloy	Sn plated
1	Housing	PA66	UL94V-0
ITEM	NAME OF PART	MATERIAL	NOTES

DRAW	SHUANGPING ZHENG	SCALE	FIT
CHECK	LICHAO LIU	UNIT	mm
APPROVE	YONGLIANG GAO	SIZE	A4
		SHEET	1/1
		PROJ.	

东莞市锦凌电子有限公司 DONGGUAN JINLING ELECTRONIC CO., LTD		PART NO.	JL15EDGKNHM-350XXXXX
		TITLE:	JL15EDGKNHM-3.5-2*XXP插拔式母座/带耳