

REV.	ECN.NO	ECN. REASON	DR
AO	0	INITIAL	HONGGUANG

Notes:

1. Material:
 - 1.1 Housing: thermoplastic high temp. UL94V-0; Color: Natural.
 - 1.2 Actuator: thermoplastic high temp. UL94V-0; Color: black.
 - 1.3 Terminal: copper alloy.
 - 1.4 Fitting Nail : copper alloy.
2. Finish:
 - 2.1 Terminal:
 - 50u" Min. Nickel underplated overall.
 - 1:1u"Gold on contact and solder area.
 - 2.2 Fitting Nail:
 - 50u" Min. Nickel underplated overall.
 - 80~150u" Matte Tin plated.
3. Product must comply HF RoHS specification.

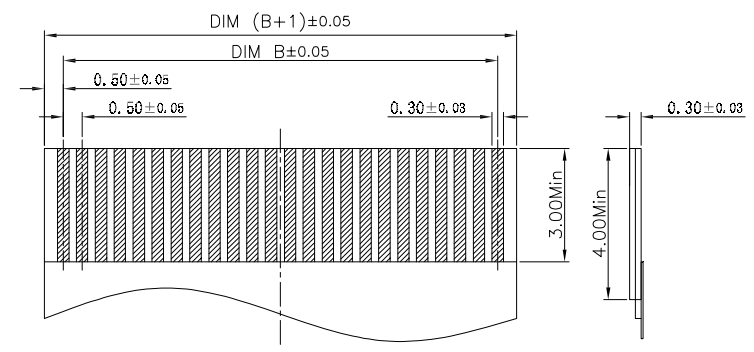
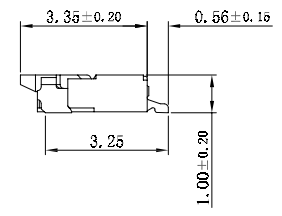
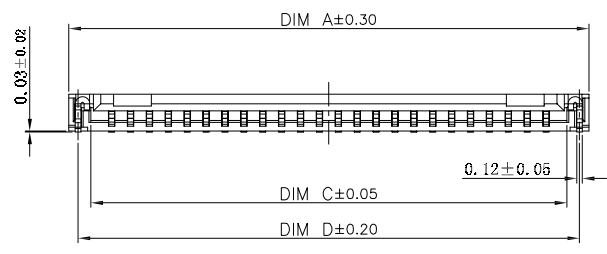
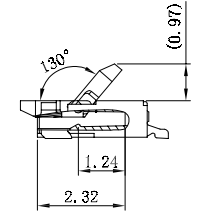
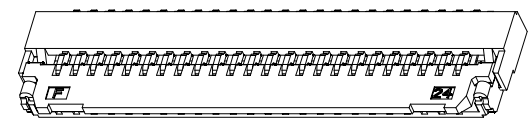
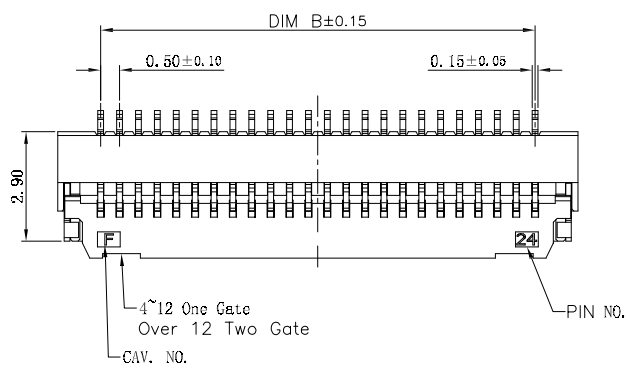

RECOMMENDED FPC DIMENSION

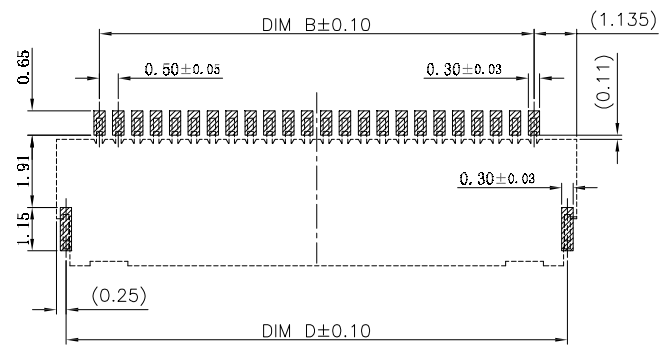

RECOMMENDED P.C.B PATTERN LAYOUT

CKT	DIM A	DIM B	DIM C	DIM D
4	3.77	1.50	2.60	3.27
5	4.27	2.00	3.10	3.77
6	4.77	2.50	3.60	4.27
7	5.27	3.00	4.10	4.77
8	5.77	3.50	4.60	5.27
9	6.27	4.00	5.10	5.77
10	6.77	4.50	5.60	6.27
11	7.27	5.00	6.10	6.77
12	7.77	5.50	6.60	7.27
13	8.27	6.00	7.10	7.77
14	8.77	6.50	7.60	8.27
15	9.27	7.00	8.10	8.77
16	9.77	7.50	8.60	9.27
17	10.27	8.00	9.10	9.77
18	10.77	8.50	9.60	10.27
19	11.27	9.00	10.10	10.77
20	11.77	9.50	10.60	11.27
21	12.27	10.00	11.10	11.77
22	12.77	10.50	11.60	12.27
23	13.27	11.00	12.10	12.77
24	13.77	11.50	12.60	13.27

		深圳市西格益电子有限公司					
SHENZHEN CGE ELECTRONIC CO.,LTD							
.X: ±0.30	.X': ±3'	UNIT:	MM	REV.	AO	TITLE:	0.5FPC H1.0 翻盖式
.XX: ±0.20	.X': ±2'	SCALE:	NA	APPROVAL:	Ken Wang		
.XXX: ±0.10	.X': ±1'	SHEET:	1 OF 2	CHECK:	Tony Kuang	P/N:	907201-XX3001
		DESIGN:	JinChengXin	DRAW NO.:	C922-00XXX		

REV.	ECN.NO	ECN. REASON	DR
AO	0	INITIAL	HONGGUANG

NOTES:

1. 10 SPROCKET HOLE PITCH CUMULATIVE TOLERANCE. $\pm 0.20\text{mm}$
2. CARRIER CAMBER NOT TO EXCEED 1mm IN 250mm.
3. ALL DIMENSIONS MEET EIA-481-C REQUIREMENTS.
4. MATERIAL: BLACK ANTI-STATIC POLYSTYRENE.
5. THICKNESS: $0.30 \pm 0.05 \text{ mm}$.
6. PACKING LENGTH PER 13" REEL : 40.40METERS.
7. COMPONENT LOAD PER 13" REEL : 5000PCS.
8. PEELING OFF FORCE OF TOP TAPE 0.1N~0.7N(10.2gf~71.4gf).

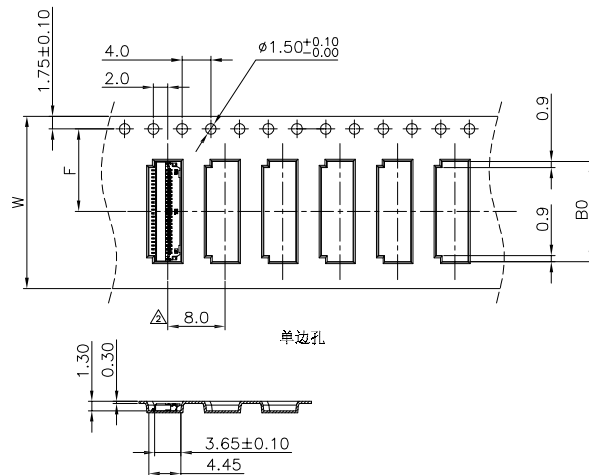
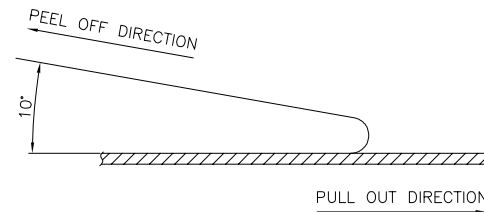
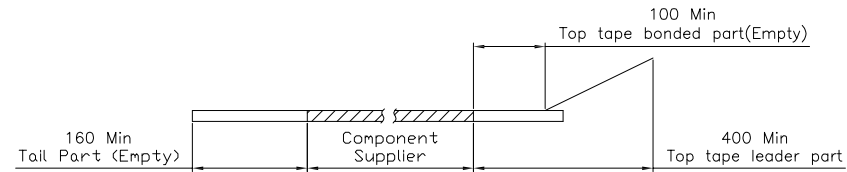
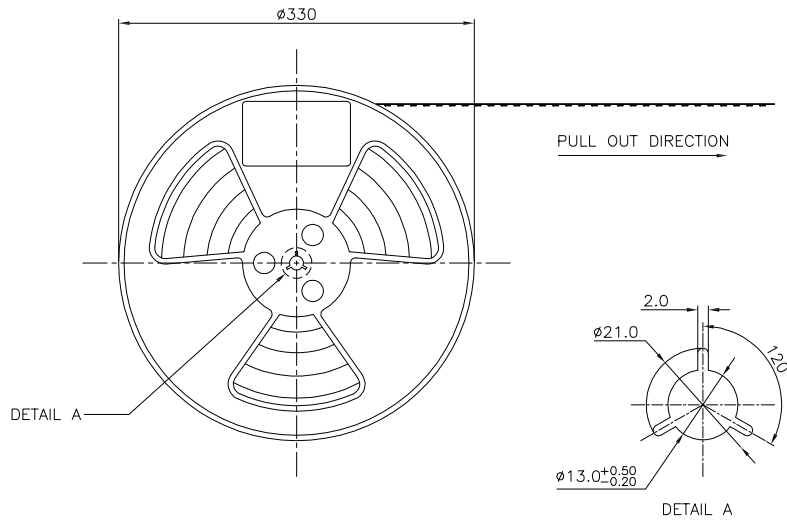
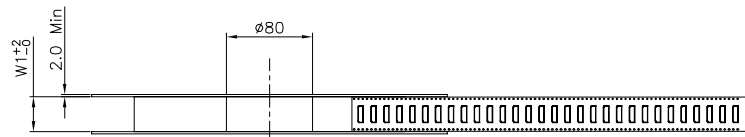

CKTS	B0±0.10	W	W1	F	S0±0.10
6	4.97	16+0.3/-0	16.4	7.5±0.10	单边孔
8	5.97				
10	6.97				
12	7.97	24+0.3/-0	24.4	11.5±0.10	
24	13.97				

		深圳市西格益电子有限公司			
		SHENZHEN CGE ELECTRONIC CO.,LTD			
X: ±0.30	X': ±3'	UNIT:	MM	REV.	AO
.XX: ±0.20	.X': ±2'	SCALE:	NA	APPROVAL:	Ken Wang
.XXX: ±0.10	.XX': ±1'	SHEET:	2 OF 2	CHECK:	Tony Kuang
		DESIGN:	JinChengXin	P/N:	907201-XX3001
		DRAW NO.	C922-00XXX		