

RoHS Compliant

APPROVAL SHEET

Issued No. : _____

DESCRIPTION : SMD 5032 XO CMOS OUTPUT
NOMINAL FREQ. : 40.000000 MHz
TAITIEN P/N : 05301-L-721-3
TAITIEN MODEL : OVKTGLJANF-40.000000MHz
REVISION : 1
DATE : 12/18/2023

Approval	Checked by	Prepared by
		

CUSTOMER : _____

CUSTOMER P/N : _____

Customer Signature
Approved:
Date:

CONTENT

SPECIFICATIONS	PAGE
ELECTRICAL SPECIFICATIONS	4-5
TEST CIRCUIT	6
OUTPUT WAVEFORM	6
RECOMMENDED IR REFLOW PROFILE	7
PRODUCT DIMENSIONS	8
PRODUCT IDENTIFICATION	8
PACKAGE INFORMATION	9

■ ELECTRICAL CHARACTERISTICS

➤ FREQUENCY

	Parameter	Min.	Typ.	Max.	Units	Remarks
1-1	Nominal Frequency		40.000000		MHz	
1-2	Frequency stability (Overall)	-50		50	ppm	Frequency stability includes frequency tolerance@25°C and frequency stability vs. operating temperature range and voltage variance.
1-3	Aging	-3		+3	ppm	Frequency drift in first year @25°C
1-4	Operating Temperature range	-40		85	°C	The operating temperature range over which the frequency stability is measured.
1-5	Storage Temperature range	-55		125	°C	

➤ POWER SUPPLY

	Parameter	Min.	Typ.	Max.	Units	Remarks
2-1	Supply voltage	1.62	1.8	1.98	V	
2-2	Current			7	mA	At maximum supply voltage
2-3	Standby current			10	uA	OE pin Low and disable frequency output

➤ INPUT

	Parameter	Min.	Typ.	Max.	Units	Remarks
3-1	OE	Output enable	0.7V _{DD}		V	High or floating(*Note1): Enable frequency output
3-2	(Tri-State)	Output disable and High-Impedance		0.3V _{DD}	V	Low: Disable frequency output

*Note 1 : A pull-up resistor of <math><30k\Omega</math> between the OE pin and V_{DD} is recommended in a high noise environment.

➤ OUTPUT

	Parameter	Min.	Typ.	Max.	Units	Remarks
4-1	Output waveform		CMOS			
4-2	Duty Cycle	45	50	55	%	
4-3	Start Time			5	mSec	
4-4	Transition Time : Rise/Fall Time			5	nSec	
4-5	Output	Output High(Logic "1")	1.62		V	
4-6	Level	Output Low(Logic "0")		0.18	V	
4-7	Output Load			15PF	pF	

➤ JITTER

	Parameter	Min.	Typ.	Max.	Units	Remarks
5-1	RMS Phase Jitter				pSec	
5-2	Period Jitter (Pk-Pk)			100	pSec	
5-3	Period Jitter (RMS)				pSec	

➤ PHASE NOISE

	Parameter	Min.	Typ.	Max.	Units	Remarks
6-1	Hz offset				dBc/Hz	
6-2	Hz offset				dBc/Hz	
6-3	Hz offset				dBc/Hz	
6-4	Hz offset				dBc/Hz	
6-5	Hz offset				dBc/Hz	
6-6	Hz offset				dBc/Hz	

■ CUSTOMER SPECIAL REQUIREMENT

7-1	1.8V					
-----	------	--	--	--	--	--

■ ENVIRONMENTAL & RELIABILITY SPECIFICATIONS

	Parameter	Reference Std.	Remarks
8-1	Thermal Shock	MIL-STD-883H 1010.8 Condition B	-55°C, 125°C; soak time is 10 mins, with total 200 cycles
8-2	Damp Heat	JESD22-A101	85°C/85% RH for 500 hrs
8-3	Low Temp Storage	IEC 60068-2-1	-55°C for 500 hrs
8-4	Drop Test	IEC 60068-2-32	70, 80, 100cm, each height for 3 times on hardboard
8-5	Mechanical Shock	MIL-STD-883H 2002.5 Condition B	1500g, half-sine, 0.5ms, each axis for 3 times.
8-6	Vibration Test	MIL-STD-883H 2007.3 Condition A	10~2000Hz, 1.52mm, 20g, each axis for 4 hrs

■ TEST CIRCUIT (CMOS LOAD)

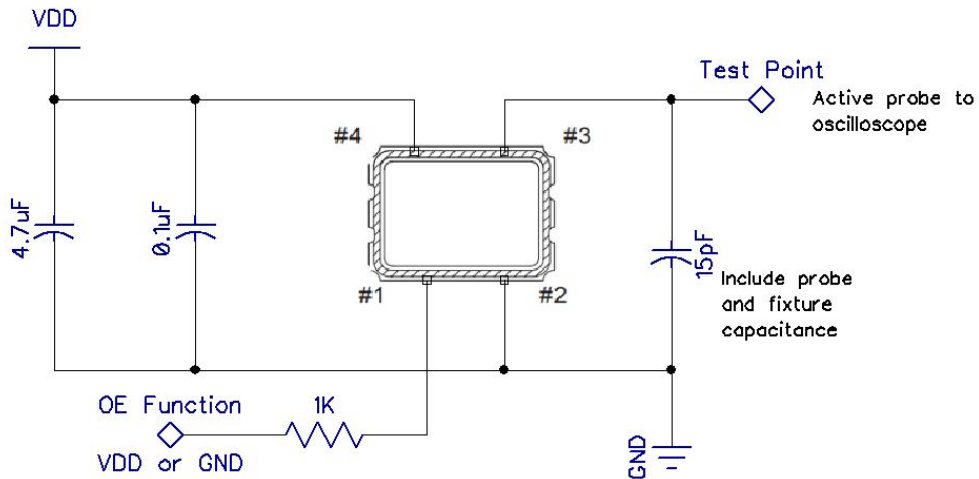

■ OUTPUT WAVEFORM (CMOS LOAD)

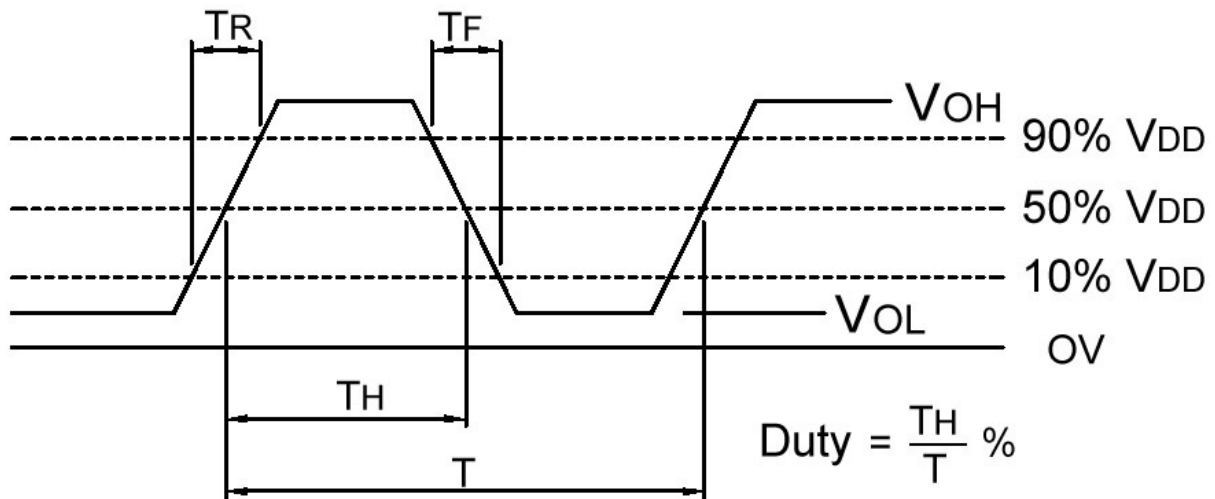

■ RECOMMENDED IR REFLOW PROFILE

- IR REFLOW PROFILE OF CERAMIC SMD PRODUCTS FOR Pb FREE PROCESS

TAITIEN ELECTRONICS CO., LTD.

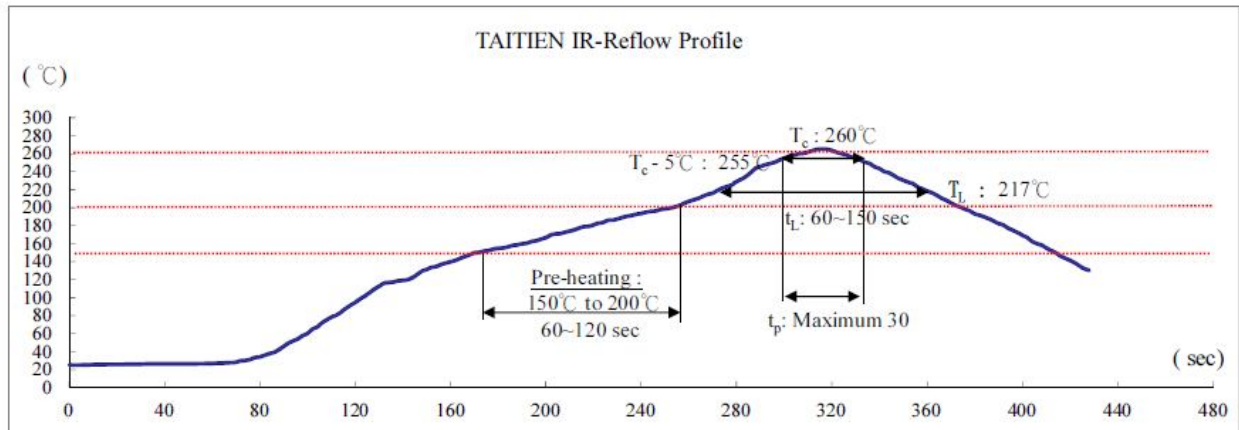

Reference Standard: JEDEC-STD 020

Test conditions: Pre-heating : 150°C to 200°C, 60~120secs.

Liquidous temperature (T_L) & Time (t_L): Heating : 217°C, 60~150sec.

T_c is 260 °C and time t_p is 30 seconds,

T_c : classification temperature ; the maximum body temperature at which the component manufacturer guarantees the component MSL as noted on the caution and/or bar code label per J-STD-033.

t_p : time within 5 °C of the specified classification temperature (T_c).

**The peak temperature must not exceed 260 °C. The time t_p above 255 °C must not exceed (Max.) 30 seconds.

■ PRODUCT DIMENSIONS

➤ DIMENSIONS

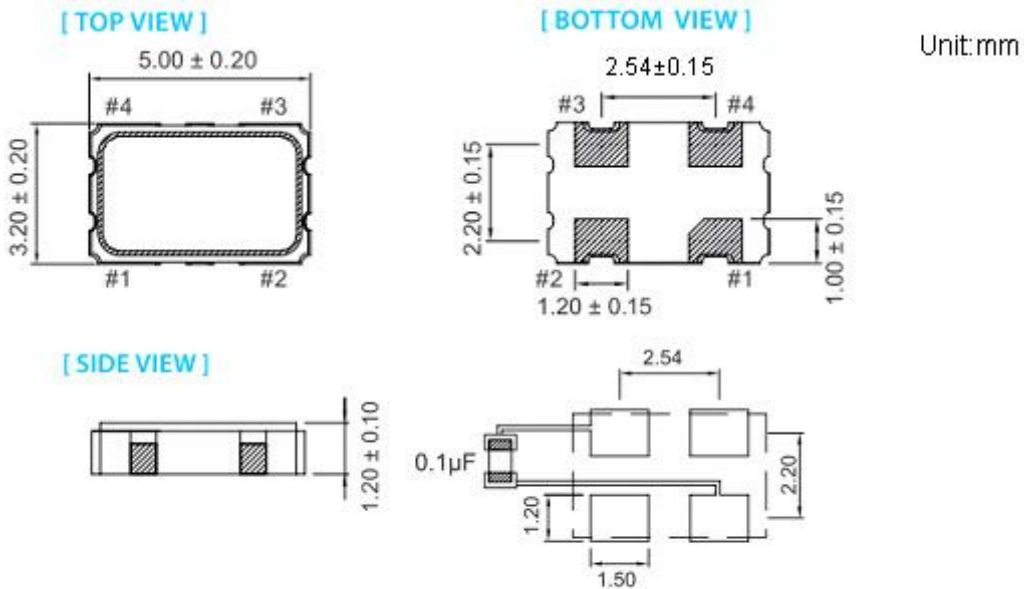

To ensure optimal oscillator performance, place a by-pass capacitor of 0.1µF as close to the part as possible between V_{DD} and GND pads.

➤ PIN FUNCTIONS

NO	Name	Type	Function and Remarks		
1	OE (Tri-state)	Input	Output control pin. Reference as below table		
			Input level	Oscillation	Outputs
			"H"	Enable	Enable: Specified frequency
"L"	Disable	Disable: Hi-Z			
2	GND	Power-	GND pin		
3	OUT	Output	Frequency output		
4	V _{DD}	Power+	Power Supply, V _{DD} pin		

■ PRODUCT IDENTIFICATION (MARKING)

➤ PROCEDURE : LASER

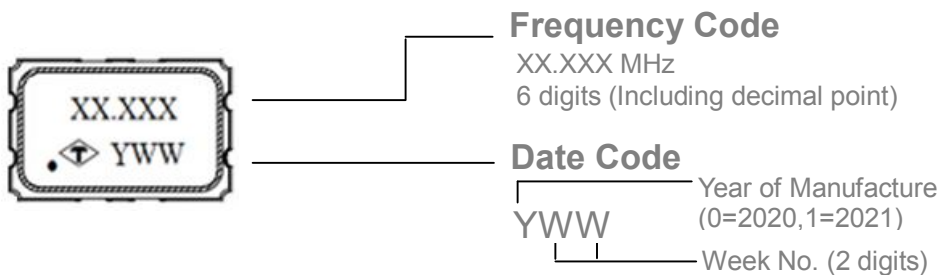

■ PACKAGE INFORMATION

➤ TAPE (CARRIER) DIMENSIONS

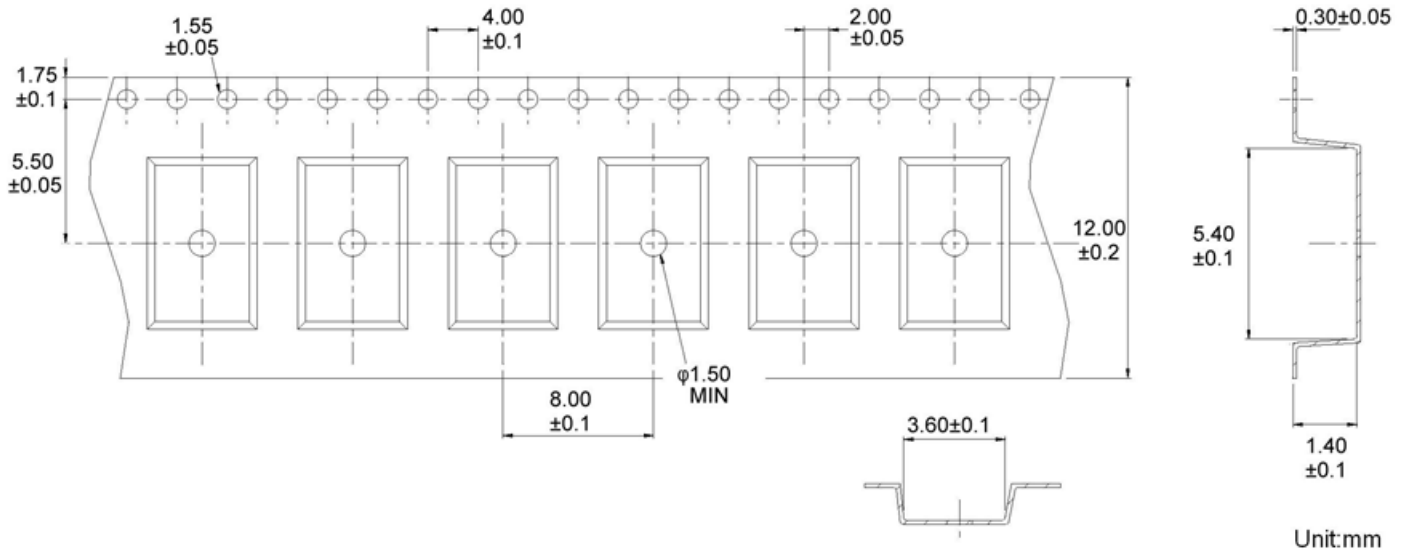

➤ THE DIRECTION OF PACKING

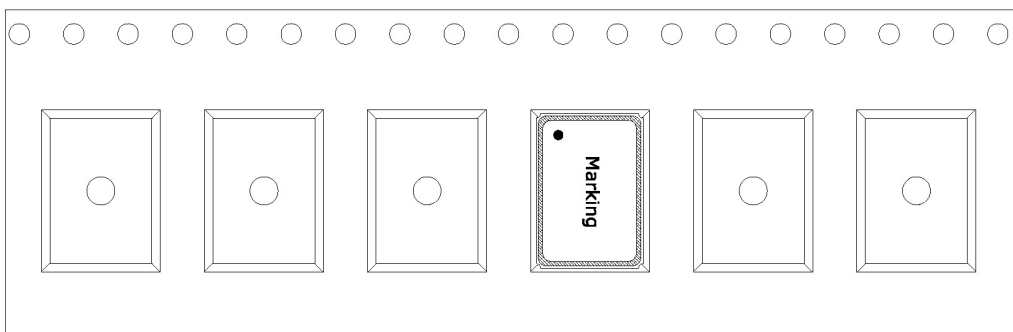

➤ REEL DIMENSIONS

