

## Specification Sheet for Approved

Customer Name:	
Customer Part No.:	
Ceaiya Part No:	CR5040 Series
Spec No:	L023-1

### 【For Customer Approval Only】

If you Approval, Please Stamp

### 【RoHS Compliant Parts】

Approved By	Checked By	Prepared By
李庆辉	刘志坚	劳水花

## Shenzhen Ceaiya Electronics Co., Ltd.

地址 1: 深圳市龙华区观湖街道鹭湖社区观盛二路 5 号捷顺科技中心 B706

地址 2: 广东省东莞清溪镇青滨东路 105 号力合紫荆智能制造中心 10 栋

Http://www.szceaiya.com

Tel: 0769-89135516

Fax: 0769-89135519

**【Version of Changed Record】**

Rev.	Effective Date	Changed Contents	Change Reasons	Approved By
A0	2024.04.25	New release	/	Li qing hui

## 1. Shape and Dimension ( Unit:mm )

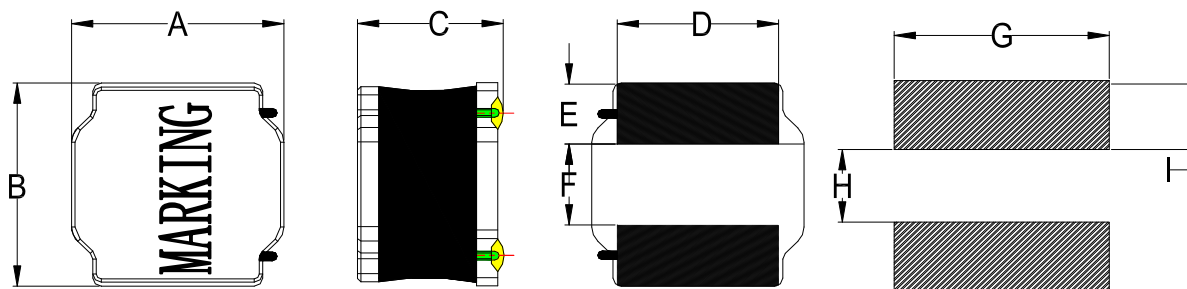

A	B	C	D	E	F	G	H	I
5.0 ± 0.2	5.0 ± 0.2	4.0Max	4.0±0.3	1.25±0.3	2.5±0.3	4.2 Ref	2.3 Ref	1.4 Ref

注：喷码尺寸：长 3.4±0.4mm,宽 2.2±0.4mm

## 2. Electronic Characteristics List

Part Number	Inductance (uH)	Tolerance (±%)	DCR(mΩ) ±30%	Isat (A)	Irise (A)	Test Condition	Marking
CR5040-R24N	0.24	30	7.5	12.0	6.50	1MHz /0.25V	R24
CR5040-R47N	0.47	30	10	8.80	6.00	1MHz /0.25V	R47
CR5040-1R0N/M	1.0	30/20	13	7.35	4.90	100KHz /0.25V	1R0
CR5040-1R5N	1.5	30	15	6.30	4.30	100KHz /0.25V	1R5
CR5040-1R8N	1.8	30	18	6.10	3.90	100KHz /0.25V	1R8
CR5040-2R2N	2.2	30	19	4.90	3.80	100KHz /0.25V	2R2
CR5040-2R7N	2.7	30	22	4.30	3.60	100KHz /0.25V	2R7
CR5040-3R3N	3.3	30	24	3.95	3.40	100KHz /0.25V	3R3
CR5040-3R9N	3.9	30	27	3.55	3.20	100KHz /0.25V	3R9
CR5040-4R7M	4.7	20	30	3.50	3.00	100KHz /0.25V	4R7
CR5040-5R6M	5.6	20	33	3.20	2.80	100KHz /0.25V	5R6
CR5040-6R8M	6.8	20	43	2.90	2.50	100KHz /0.25V	6R8
CR5040-8R2M	8.2	20	55	3.00	2.30	100KHz /0.25V	8R2
CR5040-100M	10	20	64	2.35	2.10	100KHz /0.25V	100
CR5040-150M	15	20	86	2.00	2.00	100KHz /0.25V	150
CR5040-220M	22	20	129	1.60	1.50	100KHz /0.25V	220
CR5040-270M	27	20	165	1.50	1.30	100KHz /0.25V	270
CR5040-330M	33	20	188	1.30	1.20	100KHz /0.25V	330
CR5040-390M	39	20	225	1.20	1.10	100KHz /0.25V	390
CR5040-470M	47	20	270	1.10	1.00	100KHz /0.25V	470
CR5040-560M	56	20	375	1.00	0.90	100KHz /0.25V	560
CR5040-680M	68	20	400	0.90	0.80	100KHz /0.25V	680
CR5040-101M	100	20	560	0.75	0.70	100KHz /0.25V	101
CR5040-221M	220	20	1200	0.45	0.40	100KHz/0.25V	221
CR5040-331M	330	20	2100	0.45	0.40	100KHz/0.25V	331
CR5040-471M	470	20	2800	0.40	0.30	100KHz /0.25V	471
CR5040-102M	1000	20	6600	0.25	0.20	100KHz /0.25V	102

※ All test data is referenced to 25°C ambient;

**Isat** : DC Saturation Current that will cause initial inductance to drop approximately 30% max.

**Irise** : DC Current that will cause an approximate ΔT of 40 °C

**Measuring Instrument :**

L:HIOKI3532-50

DCR:HIOKI 3540

Isat / Irise:HP4284+42841A

### 3. General Characteristics

3-1. Storage Temperature range :  $-40^{\circ}\text{C} \sim +105^{\circ}\text{C}$

3-2. Operating temperature range:  $-40^{\circ}\text{C} \sim +125^{\circ}\text{C}$  (Including coil's self temperature rise)

3-3. External appearance : No external defects can be found in the visual inspection.

3-4. Electrode strength : No electrode detachment should be found when the device is pushed in two directions of X and Y with the force of 10.0N for  $60 \pm 2$  seconds after soldering between copper plate and the electrodes.  
(Refer to figure at right)

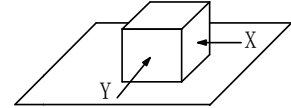

3-5. Vibration test : Inductance deviation is within  $\pm 10.0\%$  after 1 hour sweeping vibration in each three directions, namely, forward and backward, up and down, right and left. The frequency is  $10 \sim 55 \sim 10\text{Hz}$  and the amplitude of 1 minute cycle is 1.5mm PP.

3-6. Recommended reflow condition:

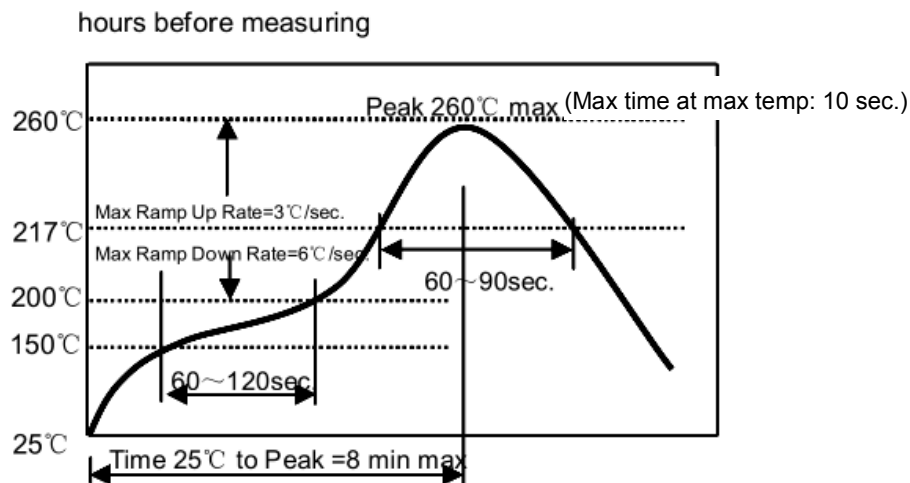

3-7. Humidity test : Inductance deviation is within  $\pm 5.0\%$  after  $96 \pm 4$  hours test under the condition of relative humidity of  $90 \sim 95\%$  and temperature of  $60 \pm 2^{\circ}\text{C}$ , and 1 hour storage under room ambient conditions after the device is wiped with dry cloth.

**LEAD-FREE**



#### 4. Construction and materials

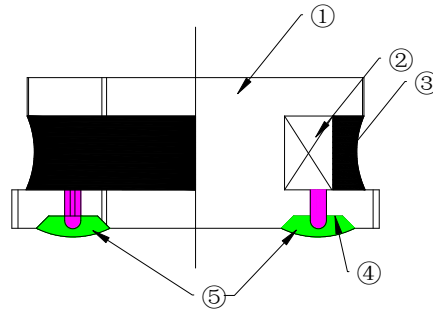

No.	Part name	Material	Ceaiya P/N
①	Drum Core	Ni-Zn Ferrite Core	MT/CY/TW
②	Wire	Polyurethane enameled copper wire	YLSL
③	Adhesive	Epoxy Resin Magnetic Powder	
④	Plating Electrodes	Plating: Ag 3-7 $\mu$ m Ni 1-3 $\mu$ m Sn 3-7 $\mu$ m	
⑤	Outer Electrodes	Top surface solder coating Sn99%、 Ag0.3%、Cu0.7%	YX

#### 5. Package Specification

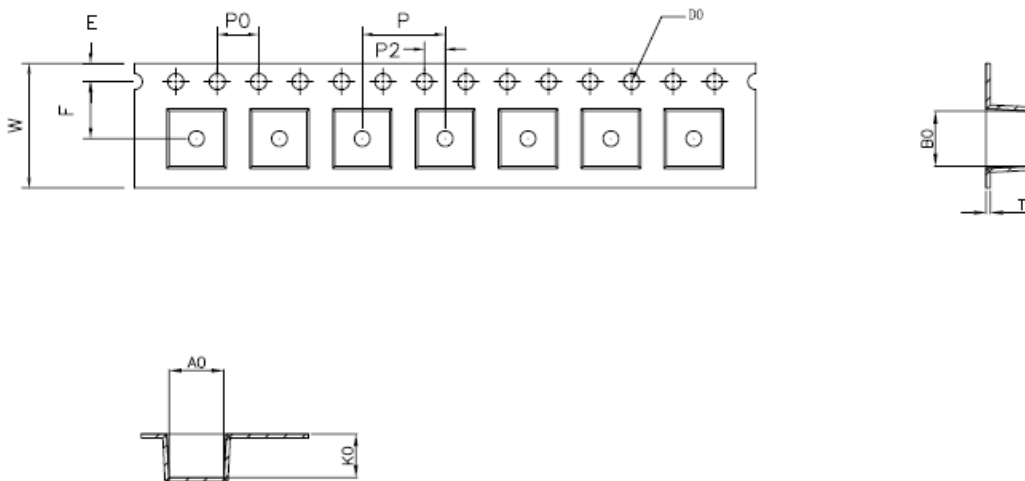

ITEM	W	A0	B0	K0	P	F	E	D0	D1	P0	P2	T
DIM	12.00	5.3	5.3	4.3	8.00	5.50	1.75	1.50	1.50	4.00	2.00	0.4
TOLE	$\pm 0.3$	$\pm 0.1$	$\pm 0.1$	$\pm 0.15$	$\pm 0.1$	$\pm 0.15$	$\pm 0.1$	+0.1	+0.1	$\pm 0.1$	$\pm 0.1$	$\pm 0.05$

## 6. CARRIER REEL DIMENSIONS:

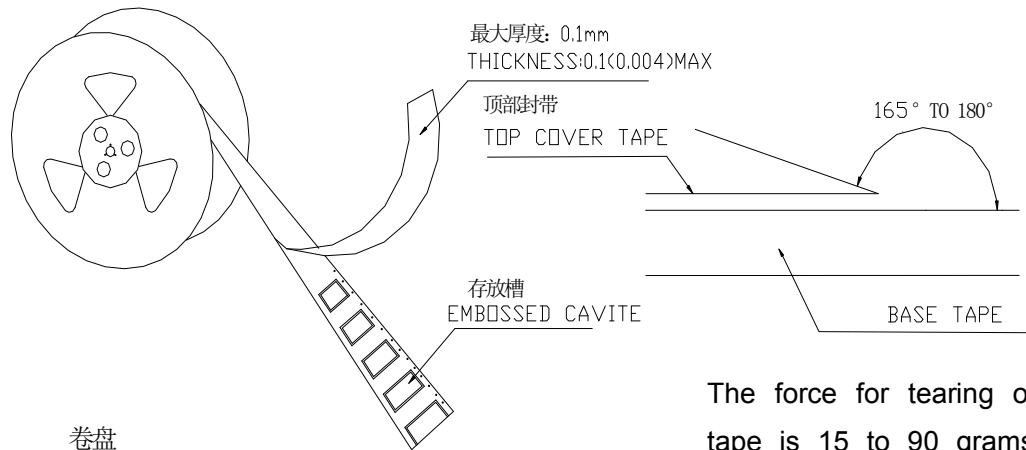

卷盘  
Carrier Tape Reel

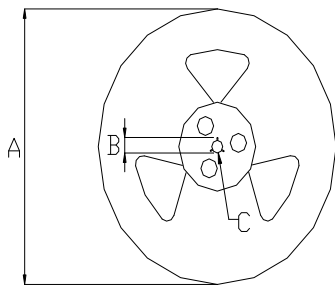

The force for tearing off cover tape is 15 to 90 grams in the arrow direction/按箭头的方向施加 15 克至 90 克力撕开

材质: 塑胶

MATERIAL: PLASTIC

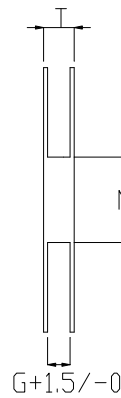

Unit: mm

Type	A	B	C	G	N	T
12mm	330	21±0.8	13±0.4	12.4	100	16.4

## 7. PACKAGE SPECIFICATION :

1.5KPCS/Reel    4.5KPCS/Inner Box    13.5KPCS/Outer Box

热封编带方向 , 如图所示

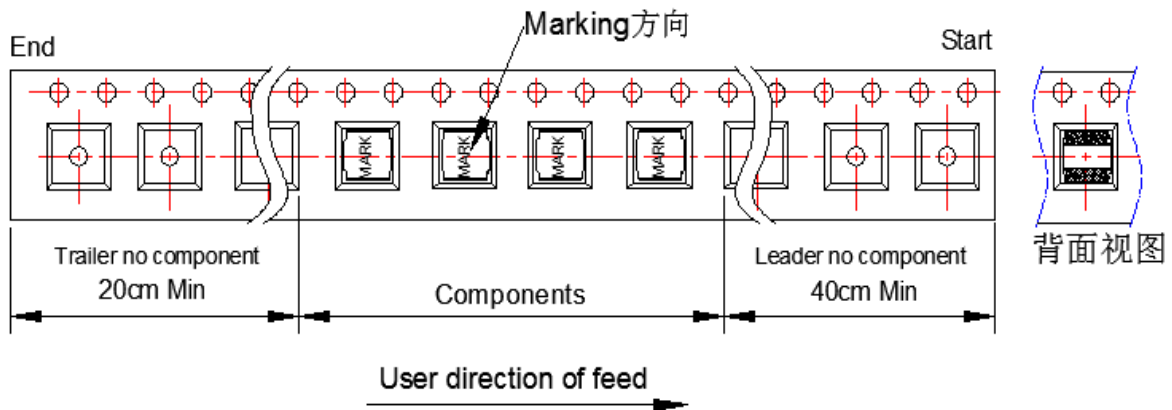

## Visual Inspection Standard of Product

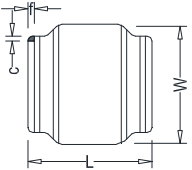
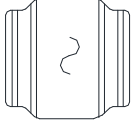
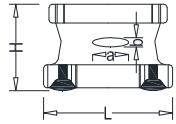
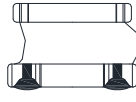
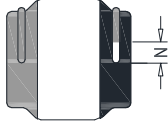
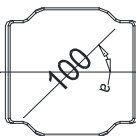
No.	Defect Item	Figure	Rejection Identification	Acceptance
1	Core Defect		The defect length(c or f) more than L/6 or W/6 , NG	AQL=0.65
2	Core Crack		Visual cracks , NG	AQL=0.65
3	Starvation		(1)Resin starved length a more than L/2, NG (2)When $L > 2\text{mm}$ , $b > H/2$ , NG (3)When $L \leq 2\text{mm}$ , b don't control	AQL=0.65
4	Excessive glue		The length, width or height of product beyond specified value, NG	AQL=0.65
5	Cold Solder		(1)For CR2520** Series , cold solder $N > 0.5\text{mm}$ , NG (2)For other series, cold solder $N > 1\text{mm}$ , NG	AQL=0.65
6	Marking Defect		The marking angle $a > 45^\circ$ , NG	AQL=0.65

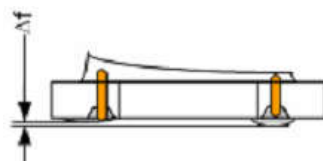

$\Delta f$ : Clearance between terminal and the surface of plate must be 0.2mm max when coil is placed on a flat plate.