

闻亭信息

The IIOWT logo, consisting of the letters "IIOWT" in a bold, sans-serif font, enclosed within a rectangular border.

产品规格书

上海闻亭信息技术有限公司
www.iiowt.com

Specification of IIOWT Supercapacitor

IIOWT 超级电容规格书

Part Number: WTR3V010F0Z-1025L

Product Spec.: WTR-3.0V-10F

Prepared 拟制	Checked 审核	Approved 批准
任倩倩	张晓丽	冯露

AMENDMENT RECORDS

修改履历

Ver. No. 版本	Description 内容	Date 日期	Checked 审核
WT00	Initial Release	30/11/2019	耿梦梵

1. General Characteristics/一般特性

No.	Items/项目	Criteria/参数值	Remark/备注
01	Operating Temperature Range 工作温度范围	-40~+65℃	(-40~+85℃@2.5V)
02	Rated Voltage 额定工作电压	3V	
03	Surge Voltage 浪涌电压	3.2V	
04	Rated Capacitance 额定容量	10F	
05	Capacitance Tolerance 容差范围	-10~+30%	
06	ESR _{AC} 交流内阻	40mΩ	1KHz
07	ESR _{DC} 直流内阻	60mΩ	
08	Rated Current 额定电流	2.6A	$I = \frac{C \cdot U}{ESR_{DC} \cdot C}, \Delta t = 5s$ 2(Δt +
09	Peak Current 峰值电流	9.3A	$I = \frac{C \cdot U}{2(\Delta t + ESR_{DC} \cdot C)}, \Delta t = 1s$
10	Short Circuit Current 短路电流	50A	$I = \frac{U}{ESR_{DC}}$
11	Leakage Current 漏电流	0.045mA	72hrs
		2.5mA	30min
12	Stored Energy 存储能量	12.5mwh	$E = \frac{1}{2} \frac{CU^2}{3600}$
13	Specific Energy 能量密度	3.9wh/kg	$\frac{E}{mass}$
14	Usable Specific Power 功率密度	5.6kw/kg	$P = \frac{0.12U^2}{ESR_{DC} \cdot mass}$
15	Impedance Match Specific Power 峰值功率密度	11.7kw/kg	$P = \frac{0.25U^2}{ESR_{DC} \cdot mass}$
16	Storage temperature Range 存储温度范围	-40~+70℃	
17	Self-discharge 自放电	>2.7V	
18	Cycle Life 循环寿命	>500,000 cycles	
19	Weight 重量	3.0g	

2.Environmental Characteristics/环境特性

No.	Items/项目	Specification/Condition/规格/条件
01	Temperature Characteristics 温度特性	$ \Delta C/C \leq 10\%$, $ESR \leq \text{specified ESR at } +65^\circ\text{C}$ +65℃, 容量变化: 初始值的 10% 以内, ESR: 不超过规定值 $ \Delta C/C \leq 30\%$, $ESR \leq 2 \text{ times of specified ESR at } -40^\circ\text{C}$ -40℃, 容量变化: 初始值的 30% 以内, ESR: 不超过 2 倍规定值
02	High temperature loaded 高温负荷	$ \Delta C/C \leq 30\%$, $ESR \leq 2 \text{ times of specified ESR at } +65^\circ\text{C}/1000\text{hrs/Rated voltage}$ +65℃, 额定电压下, 负荷 1000h, 容量变化: 初始值的 30% 以内, ESR: 不超过 2 倍规定值
03	High temperature storage 高温存储	$ \Delta C/C \leq 30\%$, $ESR \leq 2 \text{ times of specified ESR at } +70^\circ\text{C}/1000\text{hrs}$ +70℃, 高温存储 1000h, 容量变化: 初始值的 30% 以内, ESR: 不超过 2 倍规定值
04	Humidity Resistance 稳态湿热	$+40^\circ\text{C} \pm 2, 90\text{--}95\% \text{RH}, 240\text{h}, \Delta C/C \leq 30\%, ESR \leq 2 \text{ times of specified ESR}$ +40℃±2, 90--95%RH, 高温高湿存储 240h, 容量变化: 初始值的 30% 以内, ESR: 不超过 2 倍规定值

3. HIOWT P/N: 产品代码

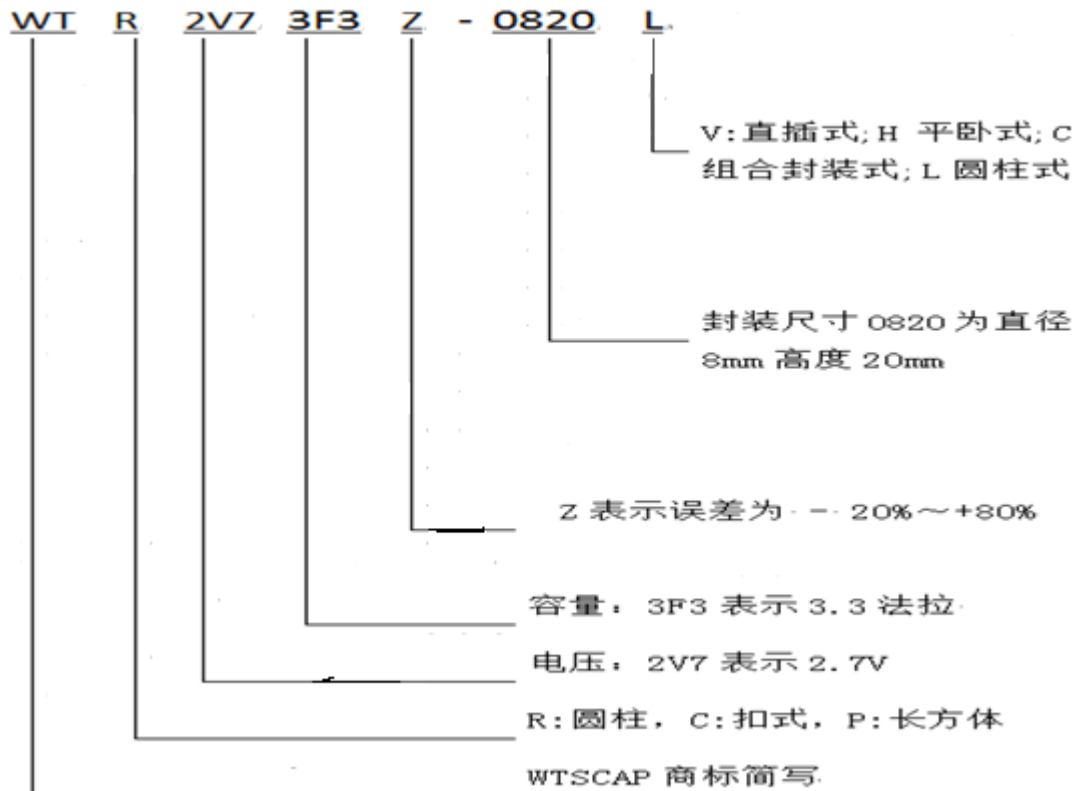

4.Product Dimensions: 产品尺寸

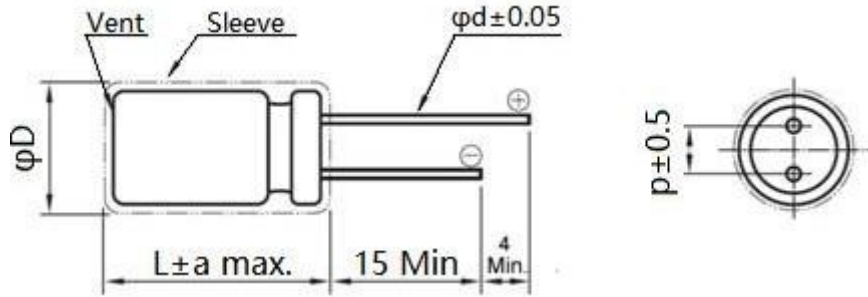

Items	Criteria	Items	Criteria
D	10+0.5mm	L	25±2mm
p	5.0±0.5 mm	d	0.6±0.05 mm

1.Packing Procedures 包装方式

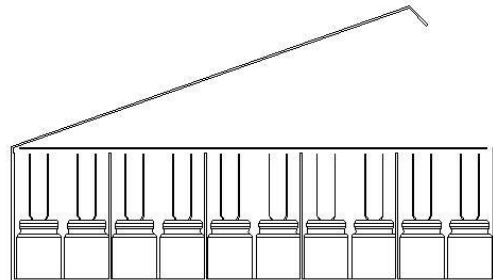
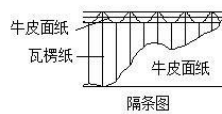
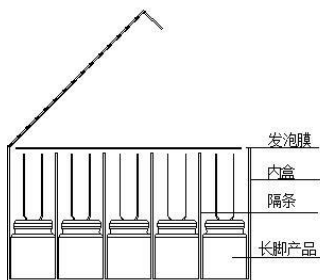
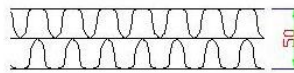
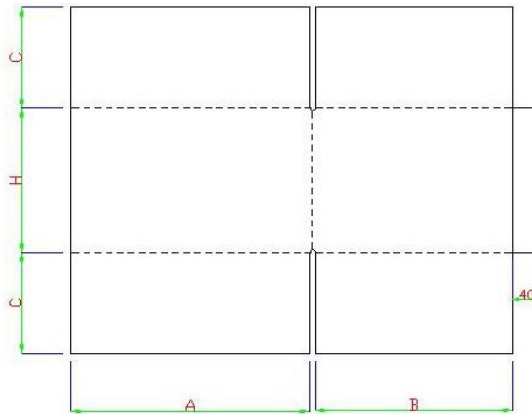
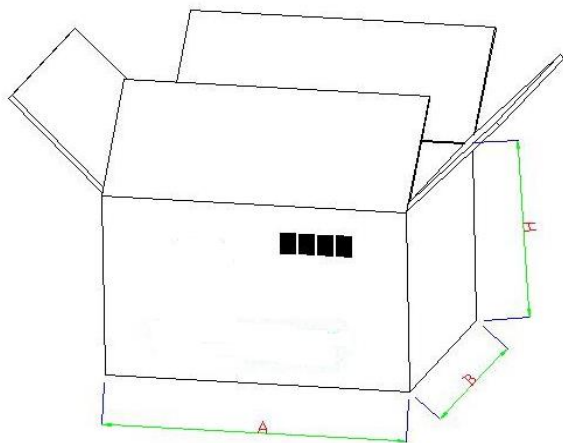

Inner Box						Outer Case					
Size(mm)			Bag	Pcs/Bag	Qty.	Size(mm)			Boxes	Pcs/Box	Qty.
A	B	H				A	B	H			
280	210	145	5	200	1000	450	300	320	4	1000	4000

1. Test Method 测试方法

6.1 CAP 容量

Capacitance is tested by constant current discharge method.

容量通过恒流放电法测试。

6.1.1 Measurements shall be carried out using the measuring circuit shown in Figure 1.

测试电路原理

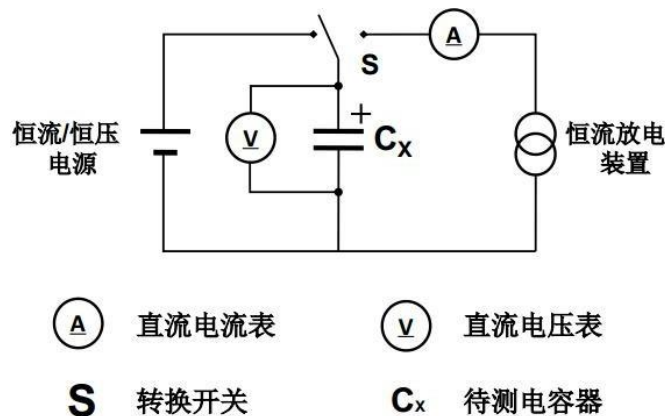

Figure 1 Constant current discharge circuit for measuring

图1 恒流放电方法电路

6.1.2 Measuring method 测量方法

- DC voltage of constant current/constant voltage source is set to rated voltage (U_R).
- 恒流/恒压源的直流电压设定为额定电压 (U_R)。
- According to 10mA/F and C_R , it set constant current for charging and discharging.
- 以 10mA/F 为基准，根据被测电容额定容量 C_R ，设置充电和放电的恒流电流值 I 。
- Charge the capacitor with standard current to rated voltage, after hold on for 30min, discharge with the same current to $0.1V$.
- 将开关S切换到直流电源，开始对被测电容进行恒流充电，待电容两端电压充电至额定电压 U_R 后，继续保持充电30 min。充电保持30 min结束后，将开关S变换到恒流放电装置，以恒定电流进行放电至 $0.1V$ 。

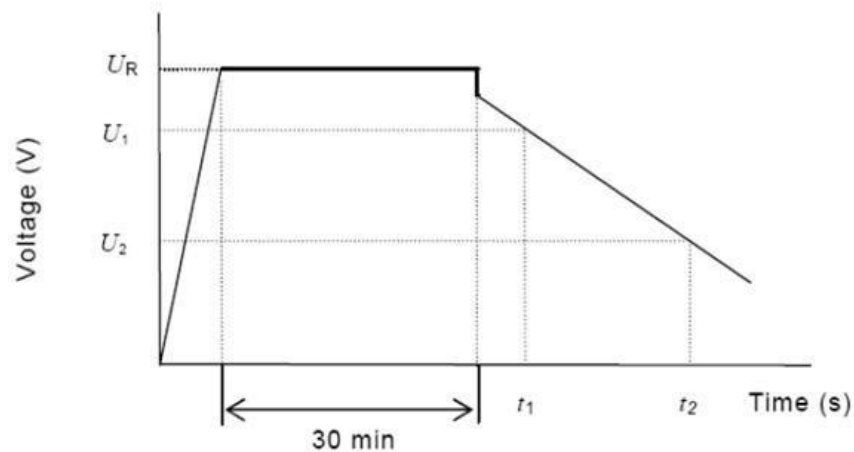

Figure 2 Voltage–time characteristics between capacitor terminals in capacitance measurement

图2 容量测试示意图

—The capacitance C of a capacitor shall be calculated by the following formula:

—测量电容器两端电压从 U_1 到 U_2 的时间 t_1 和 t_2 ，如图2所示，根据下列等式计算电容量值：

$$C = \frac{I \times (t_2 - t_1)}{U_1 - U_2}$$

Other 其他

C is the capacitance (F);

C 为容量(F);

I is the discharge current (A);

I 为放电电流(A);

U_1 is the measurement starting voltage (V), $0.8U_R$;

U_1 为测量初始电压(V), $0.8U_R$;

U_2 is the measurement end voltage (V), $0.4 U_R$;

U_2 为测量终止电压(V), $0.4U_R$;

t_1 is the time from discharge start to reach U_1 (s);

t_1 为放电初始电压到 U_1 (s)的时间;

t_2 is the time from discharge start to reach U_2 (s).

t_2 为放电初始电压达 U_2 (s)的时间。

6.2 ESR_{AC} 交流内阻

6.2.1 Measurements shall be carried out using the measuring circuit shown in Figure 3.

测试电路原理

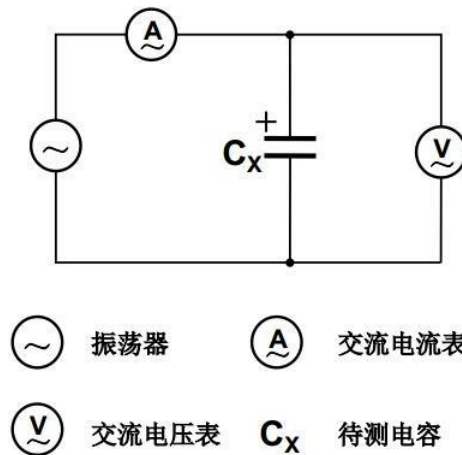

Figure 3 Circuit for a.c. resistance method

图 3 交流阻抗电路

6.2.2 Measuring method 测量方法

The AC internal resistance of capacitor shall be calculated by the following formula:

电容器的交流内阻 ESR_{AC} 应通过下式计算:

$$ESR_{AC} = \frac{U_{AC}}{I_{AC}}$$

Other 其中

ESR_{AC} is the a.c. internal resistance (Ω);

ESR_{AC} 交流内阻(Ω);

U is the effective value of a.c. voltage (V r.m.s.);

U 交流电压有效值(V r.m.s.);

I is the effective value of a.c. current (A r.m.s.).

I 交流电流有效值(A r.m.s.);

The frequency of the measuring voltage shall be 1 kHz.

测量电压的频率, 应为1kHz;

The a.c. current shall be from 5 mA.

交流电流应为5 mA;

6.3 ESR_{DC} 直流内阻

6.3.1 Measurements shall be carried out using the measuring circuit shown in Figure 4.

同容量测试电路

6.3.2 Measuring method 测试方法

—DC voltage of constant current/constant voltage source is set to rated voltage (U_R).

—恒流/恒压源的直流电压设定为额定电压 (U_R)。

—According to 10mA/F and C_R , it set constant current for charging and discharging.

—以10mA/F为基准, 根据被测电容额定容量 C_R , 设置充电和放电的恒流电流值I。

- Charge the capacitor with standard current to rated voltage, after hold on for 30min, discharge with the same current to 0.1V.
- 将开关S切换到直流电源，开始对被测电容进行充电，待电容两端电压充电至额定电压 U_R 后，继续保持充电30 min。充电保持30 min结束后，将开关S变换到恒流放电装置，以恒定电流进行放电至0.1V。

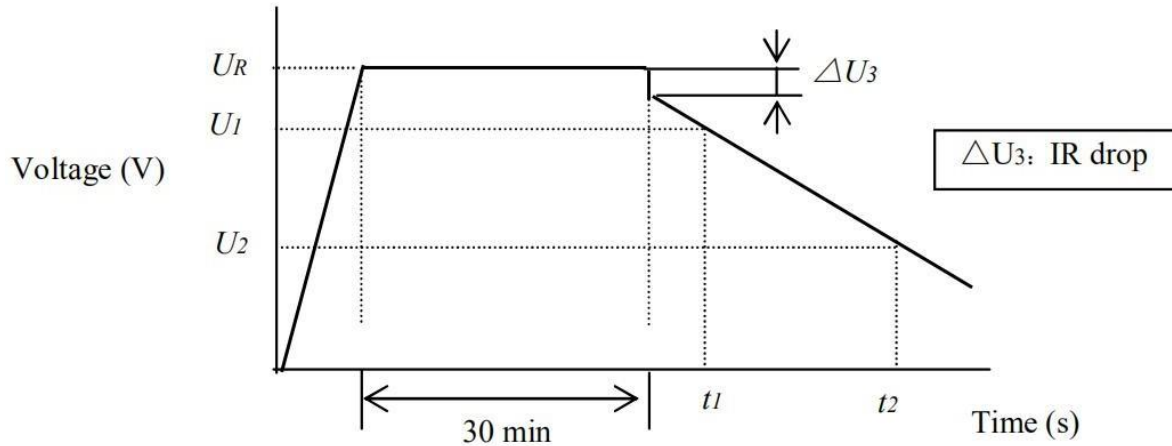

Figure 4 Circuit for d.c. resistance method

图4 直流内阻测试示意图

- The DC internal resistance of capacitor shall be calculated by the following formula:
- 用电压记录仪记录电容器充放电转换端电压瞬间30 ms 电压降的变化量 ΔU_3 ；如图4 所示。根据下式计算直流内阻 ESR_{DC} ：

$$ESR_{DC} = \frac{\Delta U_3}{2I}$$

Other 其中

ESR_{DC} is the DC- ESR (Ω);

ΔU_3 is the voltage drop during first 30ms of discharge (V);

ΔU_3 是放电前 30 毫秒的电压降(V);

I is the discharge current (A);

I为放电电流(A)。

6.4 Leakage Current 漏电流

6.4.1 Measurements shall be carried out using the measuring circuit shown in Figure 5.

测试电路原理

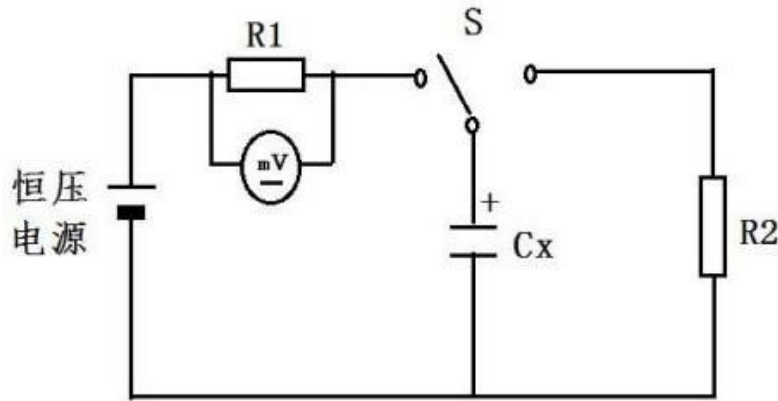

Figure 5 Circuit for leakage current

图5 漏电流电路，R1为充电电阻；R2为放电电阻；S为切换开关；Cx为被测电容。

6.4.2 Measuring method 测试方法

——the capacitor should be fully discharged with discharge resistance R2 and discharge time not less than 1h.

——将开关S切换到放电电阻R2一侧，通过R2对被测电容Cx进行放电。为实现完全放电，放电时间不低于1h，放电电阻R2参照下述公式进行选择：

$$R2 \leq \frac{3600}{5C_R}$$

——DC voltage of constant current/constant voltage source is set to rated voltage (UR).

——恒流/恒压源的直流电压设定为额定电压（UR）；

——the capacitor is continues to charge for 72 h at the rated voltage UR, record the terminal current as leakage current.

——被测电容Cx完全放电完成后，设置恒压电源输出电压为 UR，将开关S切换至R1一侧，恒压电源通过R1对被测电容开始充电，电容电压充电至UR后，继续保持充电72h，记录R1上的电压降UR1，按照下述公式计算对应时间的漏电流Ik：

$$I_{lk} = \frac{U_{R1}}{R1}$$

——Select the appropriate protective resistance R1 according to Table 1.

——按表1选择合适的保护电阻R1。

表1 电容器漏电流测试对应保护电阻值

标称容量 (F)	<7	7~80	>80
保护电阻 (Ω)	100	10	1

6.5 Self-discharge 自放电

6.5.1 Measuring method 测试方法

——the capacitor should be fully discharged and short-circuited for 6 hours.

——测量之前，电容器应充分放电，并短路6h；

——According to 10mA/F and C_R , it set constant current for charging and discharging.

——以 10mA/F 为基准，根据被测电容额定容量 C_R ，设置充电的恒流电流值 I ；

——the capacitor is charged to the voltage U_R with constant current I , the capacitor is continues to charge for 8h at the rated voltage U_R ;

——将直流电源对电容进行恒流充电至额定电压后，恒压充电8h；

——test the terminal voltage of capacitor after 24 h at open circuit under room temperature.

——在恒压充电结束后，将电容器两端从电压源断开，置于标准条件下 24 h 后，测量电容器两端的残留电压 U_c 。

2.Handling Precautions and Guidelines 注意事项和使用指导

For safety application, please contact IIOWT directly for any technical specifications, handling precautions and guidelines critical to application.

为安全起见，当设计的设备需要使用电容器时，请与闻亭直接联系咨询技术规格、安装注意事项和使用要求。

2.1 Precautions 注意事项

(1) Prohibition of disassembly 禁止拆卸

The disassembling may generate internal short circuit in the cell, which may cause gassing, leakage, explosion, or other problems.

拆卸电容会导致内部短路，可能导致产气，泄漏，爆炸或其他问题。

Electrolyte is harmful: In case the electrolyte comes into contact with the skin, or eyes, physicians shall flush the electrolyte immediately with fresh water and medical advice is to be sought.

电解液是有害的：如果电解液接触到皮肤或眼睛，应立即用清水冲洗并寻求医生的治疗。

(2) Prohibition of dumping of cells into fire 禁止将电容投入火中

These may cause explosion of the cells, which is very dangerous and is prohibited.

这可能会导致电容爆炸，这是非常危险的，是被禁止的。

(3) Prohibition of cells immersion into liquid 禁止将电容浸入液体

The cells shall never be soaked with liquids such as water, seawater, drinks such as juices, coffee or others.

电容不能用水、海水、果汁、咖啡或其他饮料等液体浸泡。

(4) Prohibition of use of damaged cells 禁止使用损坏的电容

The cells might be damaged during shipping by shock. If any abnormal features of the cells are found such as damages in the cell package, smelling of an electrolyte, an electrolyte leakage and others, the cells shall never be used any more.

在运送过程中，电容可能因受到冲击而损坏。如果发现电容有任何异常情况，如包装破损、电解液气味、电解液泄漏等，请勿使用该电容。

The Cells with a smell of the electrolyte or a leakage shall be placed away from fire to avoid firing or explosion.

有电解液味道或泄漏的电容应放置在远离火的地方，以避免起火或爆炸。

2.2 Handling Guidelines 使用指导

(1) It is not suitable that cell is used under such conditions: AC circuit and wave filtering.

不可以用于以下场合：交流电路和滤波电路。

(2) Work voltage of cell should not exceed Max. work voltage of cell during using. Otherwise, will shorten shelf life, even cause swelling, leakage or crack.

电容的工作电压不应超过电池额定最高工作电压。否则，会导致缩短使用寿命，甚至引起气胀、泄漏或开裂。

(3) Please check the polarity before using. If working under reverse polarity, cell will not only shorten shelf life, but also heavy damage, such as swelling, electrolyte leakage etc.

使用前请检查极性。如果在反极性下工作，电容不仅会缩短使用寿命，甚至还会造成严重的损坏，如气胀、电解液泄漏等。

(4) Environment 环境

Work temperature will have an influence on shelf life of cell. As usual, higher work temperature will shorten shelf life. So, it is better that cell works under as possible as low environmental temperature.

工作温度会影响电容的使用寿命。通常，较高的工作温度会缩短使用寿命。因此，最好是在低环境温度下工作。

Work temperature of cell should consider internal work temperature in the unit and temperature rise when cell works.

电容的工作温度应考虑机组内部工作温度和电容工作时的内部温升。

(5) IR drop IR 下降

When main power sources shut down, cell will change into work mode from failure mode, at the same time, OCV will decrease due to IR drop. So please choose proper product type according to impedance specified in product datasheet and applied current.

当主电源关闭，电容会从电源失效检测模式转变为后备电源工作模式，此时由于瞬间启动电流和电容内阻会导致开路电压下降。因此，请根据产品规格书和应用电流中指定的阻抗选择合适的产品类型。

(6) Cells in series connection 串联连接的电容

When cells in series connection for higher work voltage, it should be assured that work voltage of any single cell must not exceed Max. work voltage of single cell, otherwise, will shorten shelf life, even cause swelling, leakage or crack.

当多个单体电容串联使用以提高工作电压时，应保证每个电容的工作电压不得超过电容的

最大工作电压，否则会缩短寿命，甚至引起气胀、泄漏或开裂。

(7) Soldering 焊接

Manual Soldering: The recommended temperature of the soldering rod tip is less than 350 °C and the soldering duration should be less than 4 seconds. Minimize the time that the soldering iron is in direct contact with the terminals of the capacitor, as excessive heating of the leads may lead to higher ESR.

手工焊接：推荐的钎头温度低于 350 °C，焊接时间不超过 4 秒。尽量缩短烙铁与电容器端子直接接触的时间，因为引线过热可能导致更高的 ESR。

Reflow Soldering : Do not use reflow soldering, infrared or convection methods on EDLC.

回流焊：不要在 EDLC 上使用回流焊、红外线或对流方法。

Wave Soldering : Use a maximum preheating time of 60 seconds for PC board 0.8mm or thicker.

Preheating temperature should be limited to less than 100 °C.

波峰焊：对于 0.8 毫米或更厚的 PC 板，最长预热时间为 60 秒。预热温度应限制在 100 °C 以下。

Use the following table for wave soldering on leads only:

仅在导线上使用下表进行波峰焊接：

Soldering Bath Temperature(°C)	Recommended Solder Exposure (s)	Maximum Solder Exposure(s)
220	7	9
240	7	9
250	5	7
265	3	5

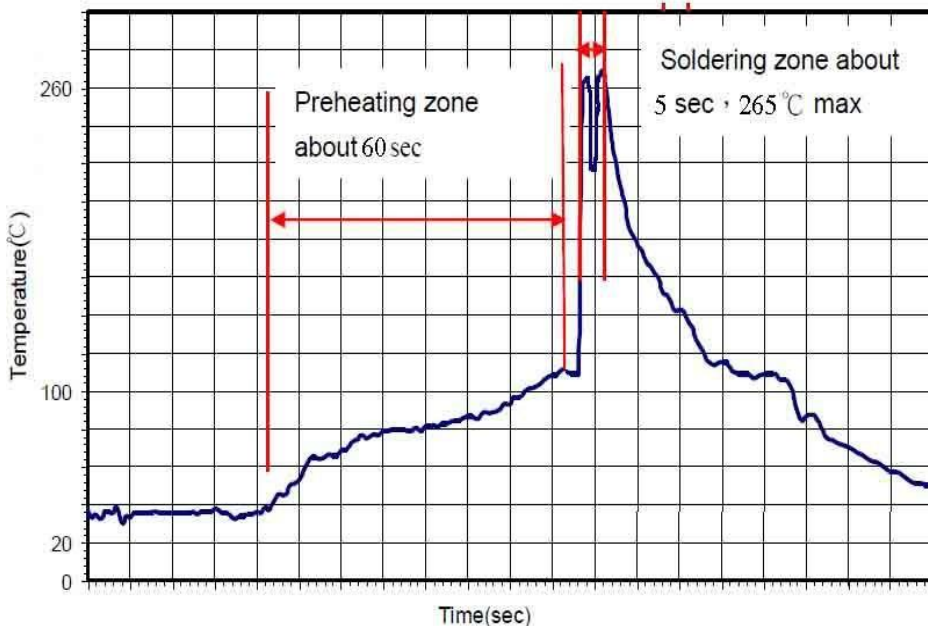

(8) Storage 存储说明

It is recommended that EDLC be stored at ambient temperature of 5°C to 35°C and a relative humidity of 75% or below.

建议 EDLC 保存在环境温度 5°C~35°C，相对湿度 75%或以下。

If the product has not been used for 2years or more, please confirm the product performance or contact us before use, as its characteristics may have been affected by environmental conditions.

如果产品放置 2 年或 2 年以上未对其施加电压，请在使用该零件前确认产品性能或者与我们联系，因为其特性可能受到环境条件的影响。

TEL:18616858996

www.iiowt.com

客服信箱: service@wtscap.co