



Y.LIN ELECTRONICS CO.,LTD.

## Data Sheet

---

Customer: F11A800064  
Part No: YLS191/O/21/06-SKS  
Sample No: S191217012  
Description: 0603 Orange SMD  
Item No: \_\_\_\_\_  
Item No: 01.01.11.000871

Customer			
Check	Inspection	Approval	Date

Y.LIN			
Drawn	Check	Approval	Date
			2021/8/2

TEL:0769-87181888 FAX:0769-87187333

E-mail:yonglin@y-lin.com Http://www.yong-lin.net

Mainland address:NO.3 Xinguang Road,Jinhe the third Industrial Zone,Zhangmutou Town

Dongguan Guangdong China

---





**Features:**

- . Reflow Solderable
- . High Luminous Intensity and Low Power Dissipation
- . Good Reliability and Long Life
- . Complied With RoHS Directive



**Applications**

- Optical indicator
- Indoor display
- Backlighting in dashboard and switch
- Flat backlighting for LCD, symbol and display
- General use

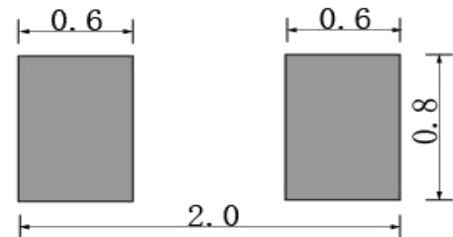
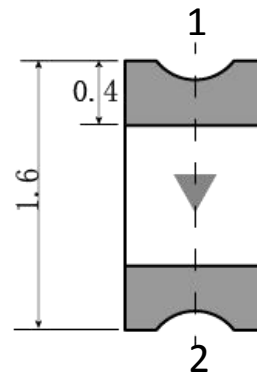
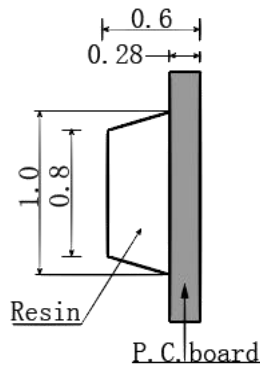
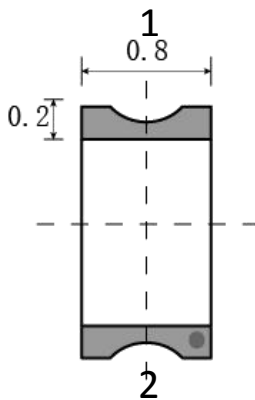

Notes:

- 1 . All dimension units are millimeters.
2. All dimension tolerance is  $\pm 0.2$ mm unless otherwise noted.
3. All PCB and markings are subject to change without prior notice.
4. Polarity mark: ▼ or ▱

**Selection Guide**

Part No.	Emitting Color	Lens Type	Luminous intensity(mcd) @ 5mA			Viewing Angle
			Min	Typ	Max	2θ1/2
YLS191/O/21/06-SKS	Orange	Water Clear	20	--	70	120

Note:

1.2θ1/2 is the angle from optical centerline where the luminous intensity is 2θ1/2 the optical centerline value.

2.The above luminous intensity measurement allowance tolerance ±10%

**Electrical / Optical Characteristics at Ta=25°C**

Parameter	Symbol	Min.	Typ.	Max	Units	test conditions
Forward Voltage	VF	1.6	--	2.2	V	IF=5mA
Reverse Current	IR	--	--	10	uA	VR = 5V
Half wave width	Δλ	--	20	--	nm	IF=5mA
Dominate Wavelength	λd	600	--	609	nm	IF=5mA

**Absolute Maximum Ratings at Ta=25°C**

Parameter	Symbol	Rating	Units
Power Dissipation	Pd	44	mW
DC Forward Current	IF	20	mA
Peak Forward Current [1]	IFP	75	mA
Reverse Voltage	VR	5	V
Electrostatic Discharge (HBM)	ESD	2000	V
Operating Temperature	Topr	-40~+85	°C
Storage Temperature	Tstg	-40~+100	°C

Note:

1. 1/10 Dut cycle,0.1ms pulse width.

2. The above forward voltage measurement allowance tolerance ±0.1V.

3. The tolerance of wave length:±1nm.



Typical optical characteristics curves

Ambient Temperature VS. Forward Current

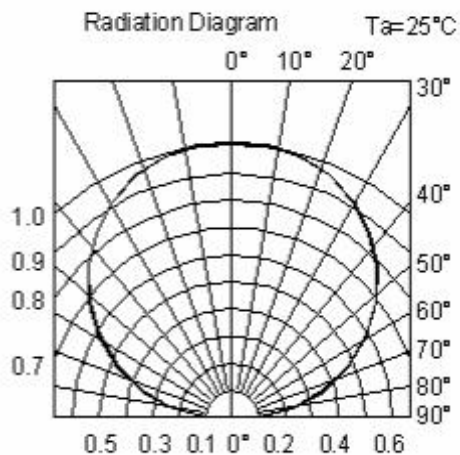
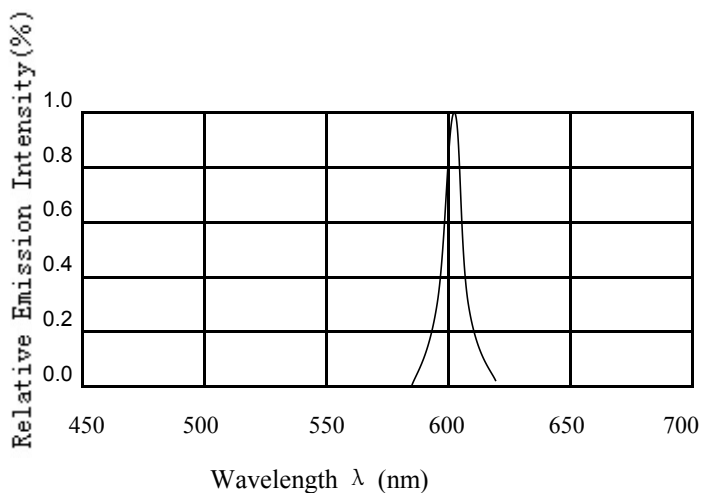
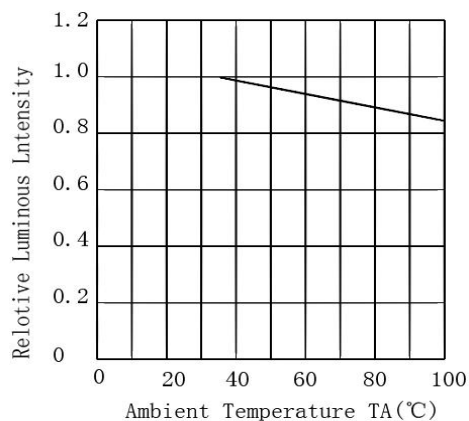
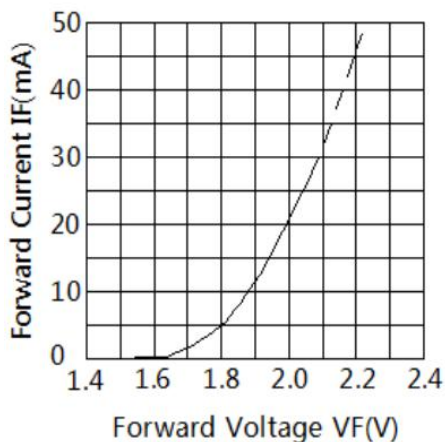
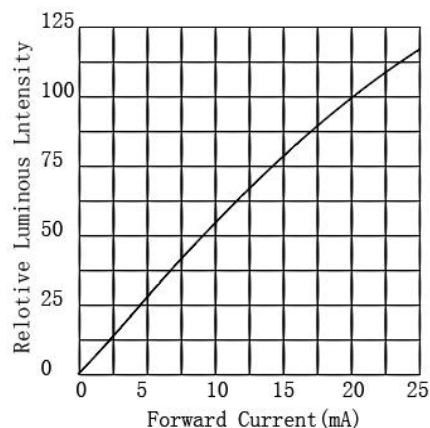
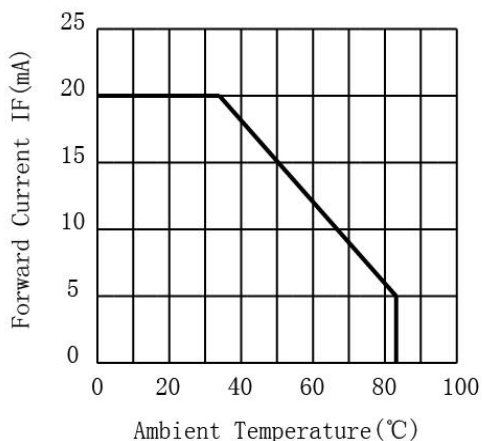



## Reliability Test Items And Conditions

Test Items	Ref.Standard	Test conditions	Time	Quantity	Ac/Re
Reflow Soldering	JESD22-B106	Temp.:260°C±5°C Min.5sec.	3 times.	22Pcs.	0/1
Temperature Cycle	JESD22-A104	100°C±5°C 30 min. ↑↓5 min -40°C±5°C 30 min.	100 Cycles	22Pcs.	0/1
High Temperature Storage	JESD22-A103	Temp:100°C±5°C	1000Hrs	22Pcs.	0/1
Low Temperature Storage	JESD22-A119	Temp:-40°C±5°C	1000Hrs	22Pcs.	0/1
Life Test	JESD22-A108	Ta=25°C±5°C IF=5mA	1000Hrs	22Pcs.	0/1
High temperature and high humidity storage experiment	JESD22-A101	85°C±5°C/ 85%RH	1000Hrs	22Pcs.	0/1

## Criteria For Judging Damage

Test Items	Symbol	Test conditions	Criteria For Judgement	
			Min.	Max.
Forward Voltage	VF	IF=5mA		U.S.L*)x1.1
Reverse Current	IR	VR = 5V		U.S.L*)x2.0
Luminous intensity	IV	IF=5mA	L.S.L*)x0.7	

U.S.L: Upper standard level      L.S.L: Lower standard level

The technical information shown in the data sheets are limited to the typical characteristics and circuit examples of the referenced products.It does not constitute the warranting of industrial property nor the granting of any license.

## SMT Reflow Soldering Instructions

- 1.High temperature welding recommended no more than 2 times.
2. When soldering , do not put stress on the LEDs during heating .
- 3.Reflow temperature distribution (Acc.to J-STD-020D)

Profile Feature	Sn-Pb Eutectic Assembly		Pb-Free Assembly	
	Large Body	Small Body	Large Body	Small Body
Average ramp-up rate (TL to Tp)	3°C/second max.		3°C/second max.	
Preheat	100°C		150°C	
-Temperature Min(TSmin)	150°C		200°C	
-Temperature Max(TSmax)	60-120 seconds		60-180 seconds	
-Time(min to max)(ts)				
Tsmax to TL			3°C/second max.	
-Ramp-up Rate				
Time maintained above:	183°C		217°C	
-Temperature(TL)	60-150 seconds		60-150 seconds	
-Time(tL)				
Peak Temperature(Tp)	225+0/-5°C	240+0/-5°C	245+0/-5°C	260+0/-5°C
Time within 5°C of actual Peak Temperature(tp)	10-30 seconds	10-30 seconds	10-30 seconds	20-40 seconds
Ramp-down Rate	6°C/second max.		6°C/second max.	
Time 25°C to Peak Temperatur	6 minutes max.		8 minutes max.	

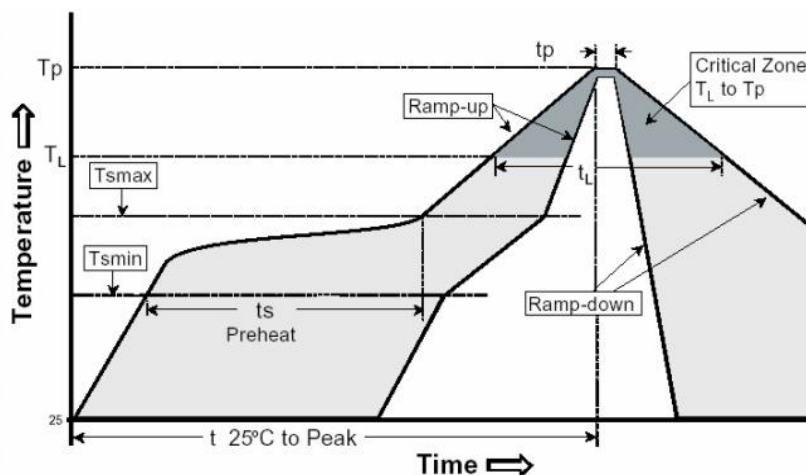

## Soldering iron

- 1.When hand soldering, the temperature of the iron must less than 350°C for 3 seconds
- 2.The hand solder should be done only one times

## Repairing

Repair should not be done after the LEDs have been soldered. When repairing is unavoidable, a double-head soldering iron should be used(as below figure). It should be confirmed in advance whether the characteristics of LEDs will or will not be damaged by repairing.

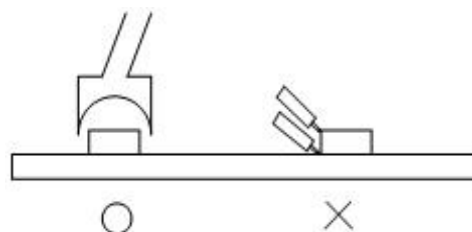



## Storage

Before the package is opened:

The storage environment shall be between 5 °C and 30 °C and the relative humidity shall be within 60 % RH. When the storage time of the product exceeds 1 year, the product must be re-baked before it can be used.

After opening the package:

- 1、 The ambient temperature should be kept between  $\leq 30$  ° C and relative humidity The lower 60 % RH should be maintained.
2. If the material has not been produced after being exposed in the workshop for more than 672 hours, the product must be put back into the oven and dehumidified at 65 °C for 12H before reuse.
- 3、 When the material is dehumidified, please do not open the oven in the middle, so that the oven temperature will not drop to the dehumidification effect.

## ESD

Static Electricity will damage the LED.

The following procedures may decrease the possibility of ESD damage.

- 1.All productive machinery and test instruments must be electrically grounded.
- 2.Use a conductive wrist band or anti-electrostatic glove when handling these LEDs.
- 3.Manintain a humidity level of 50%RH or higher in production areas.
- 4.Use anti-static packaging for transport and storage.

## Handling Precautions

- 1.Do not stack together assembled PCBs containing LEDs. Impact may scratch the silicone lens or damage.
- 2.Not available in the situation of acidity for PH.
- 3.Electrostatic sensitive device

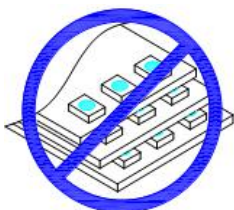





YLS191/O/21/06-SKS

Carrier tape

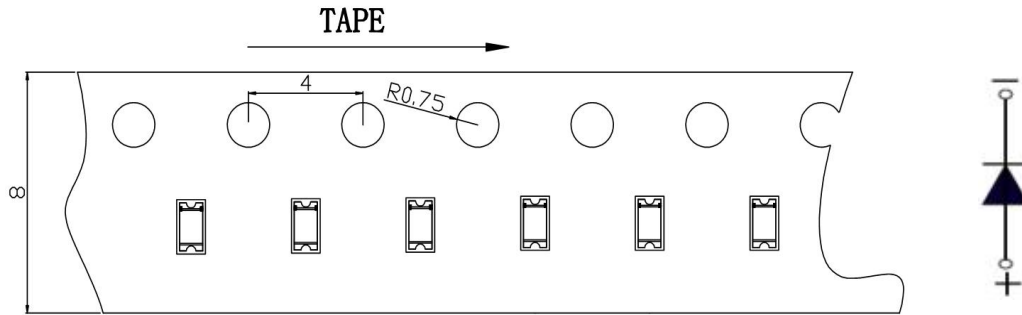

MPQ:4000PCS/Small reel

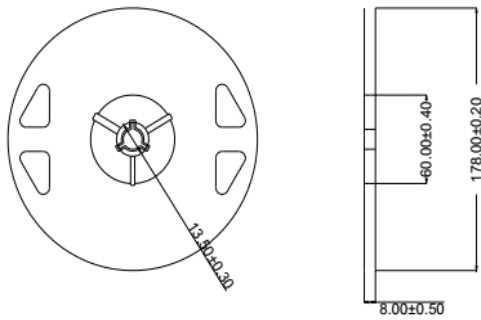

MPQ:20000PCS/Big reel

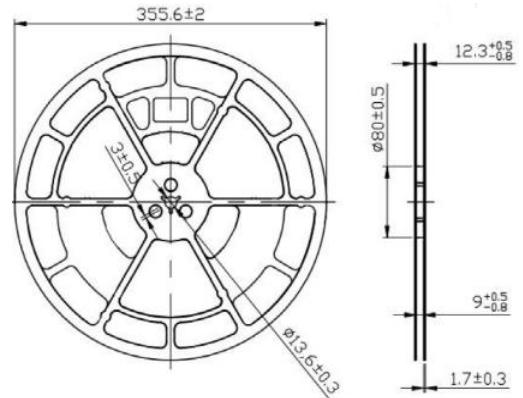

Moisture Resistant Packaging

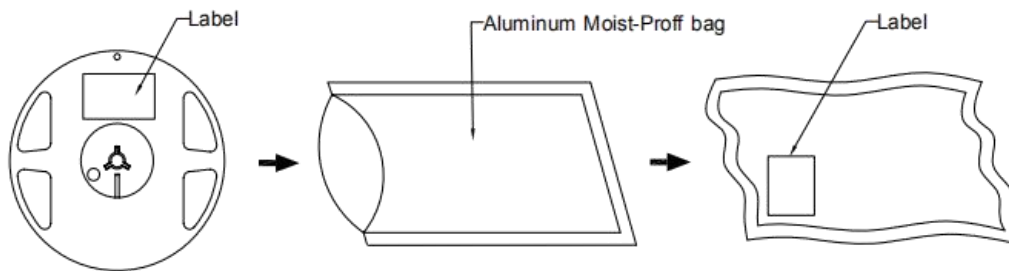

Cardboard Box

Maximum packing quantity (5 packs of material)

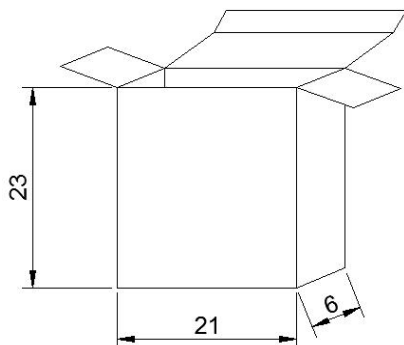

Maximum packing quantity (27 bags of material or 5 small boxes)

