

GPIO use guide:

- Note that the voltage of SOC GPIO must matches the external IO voltage.
- The pull up voltage of the GPIO is selected to correspond to the power field voltage of GPIO.

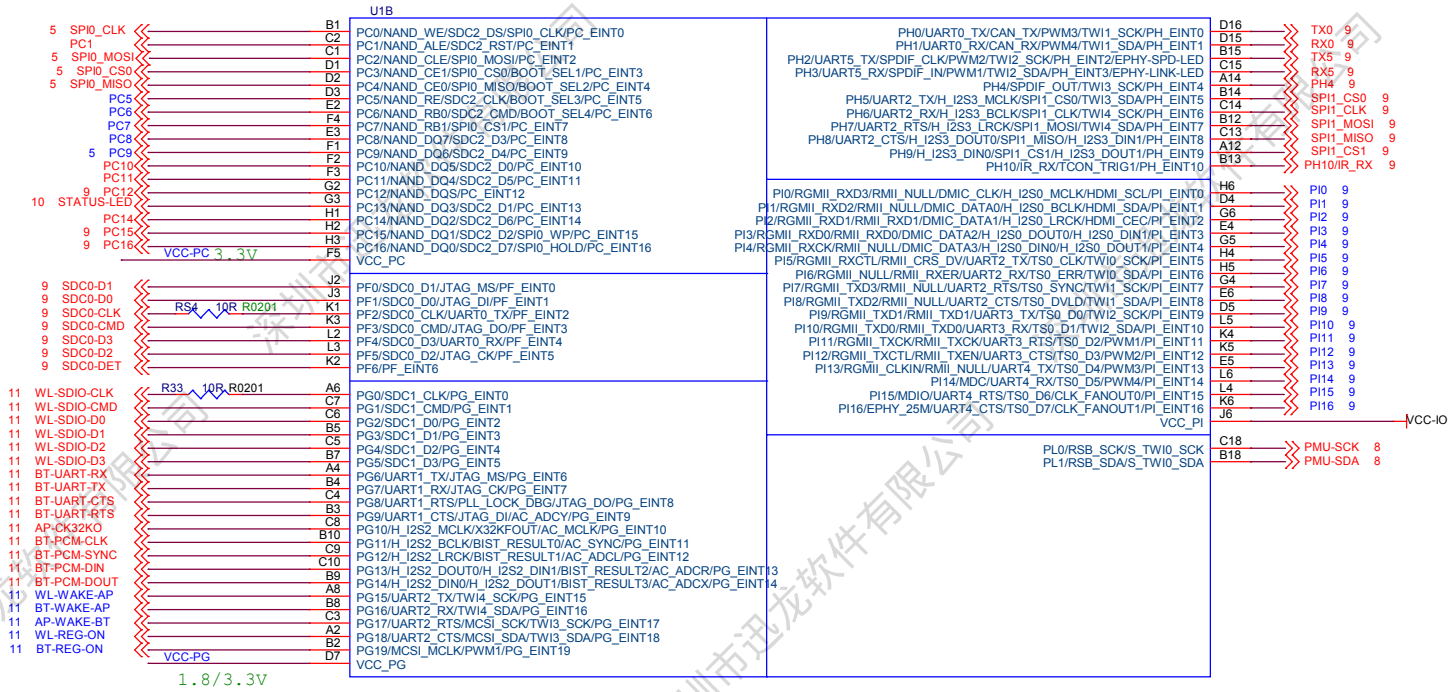

1.8/3.3V

H616-BGA-284

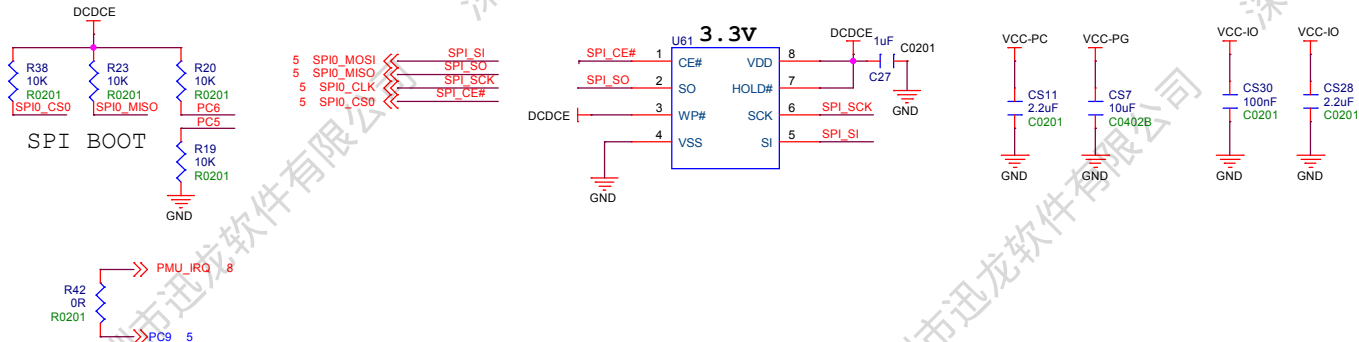

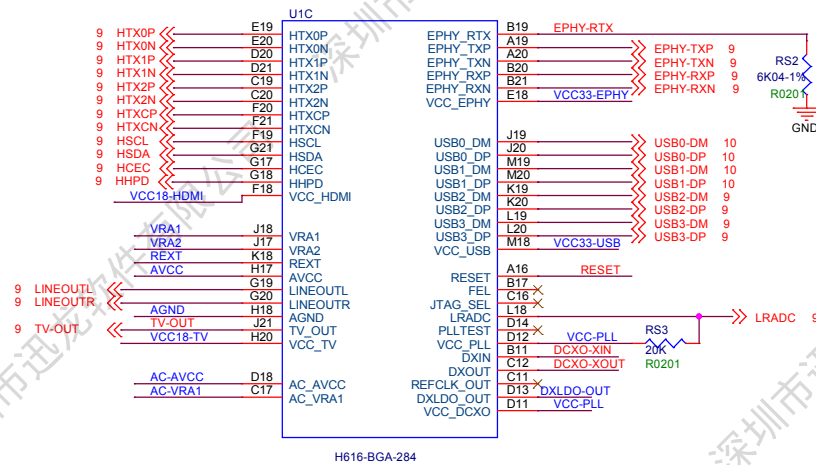

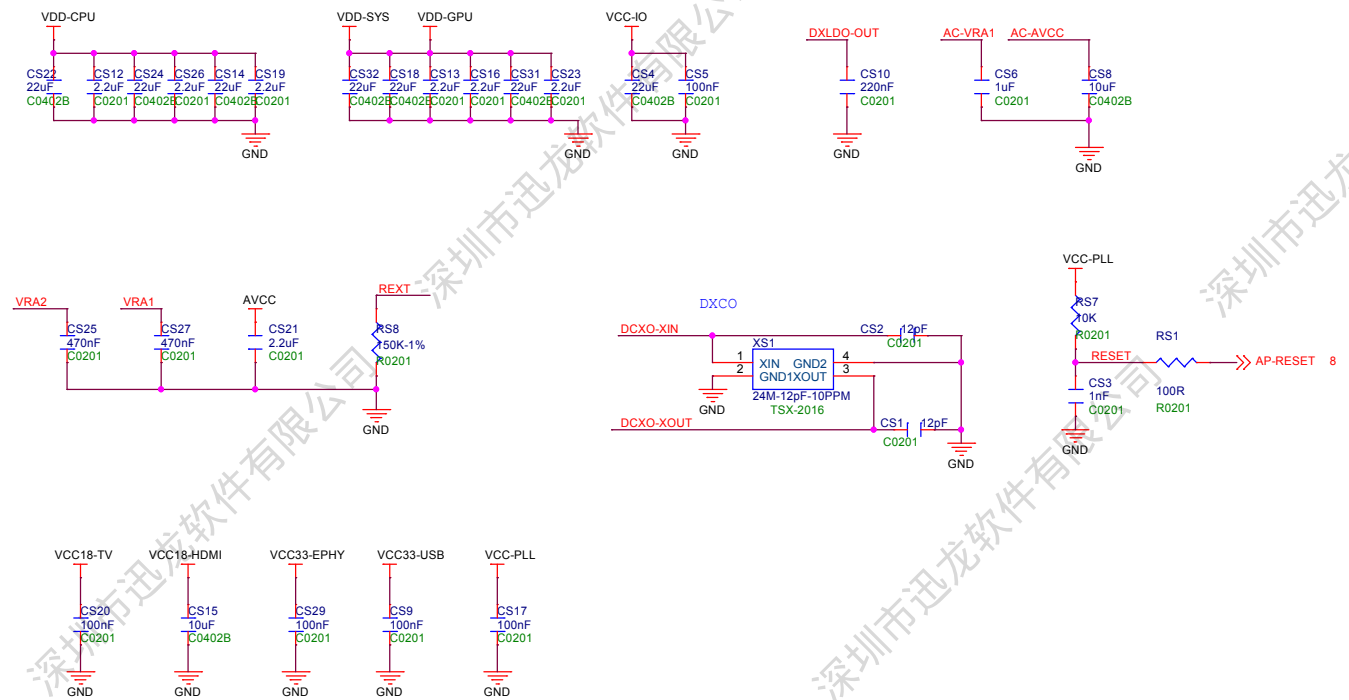

H616-BGA-284

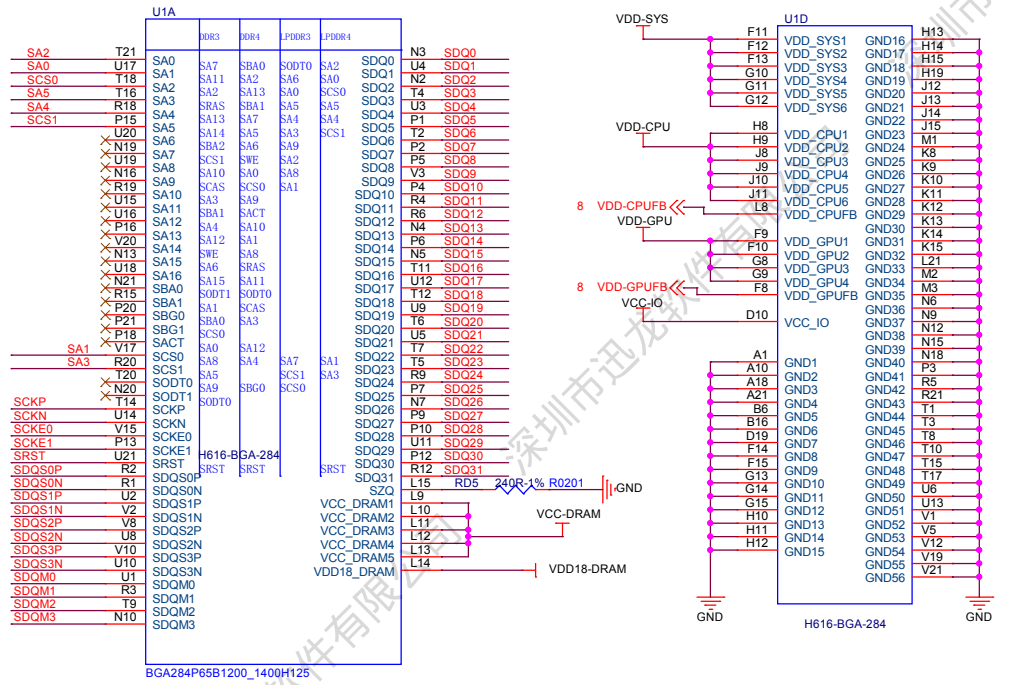

LPDDR4

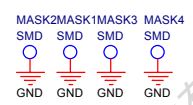
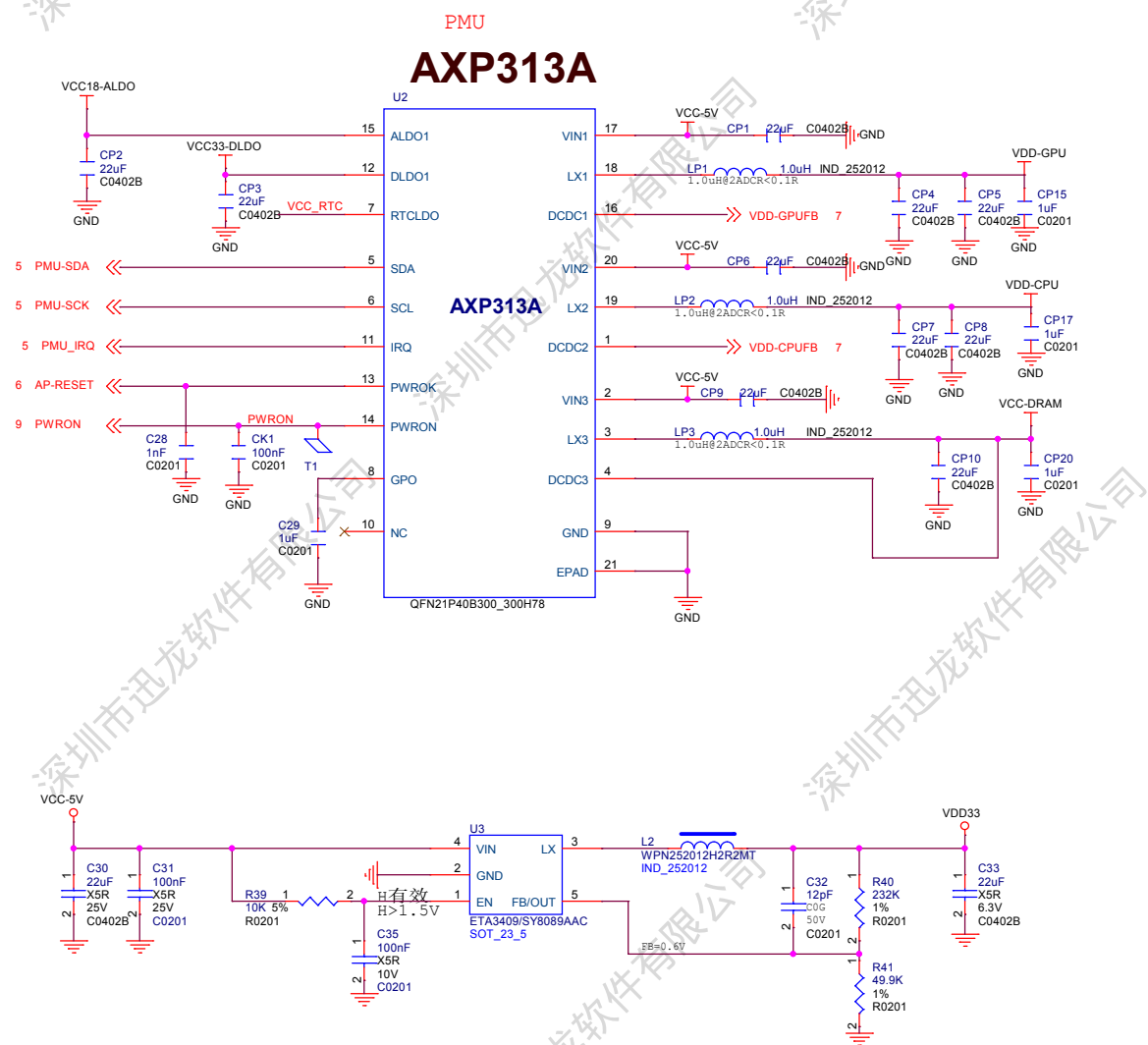
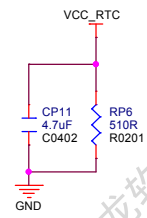
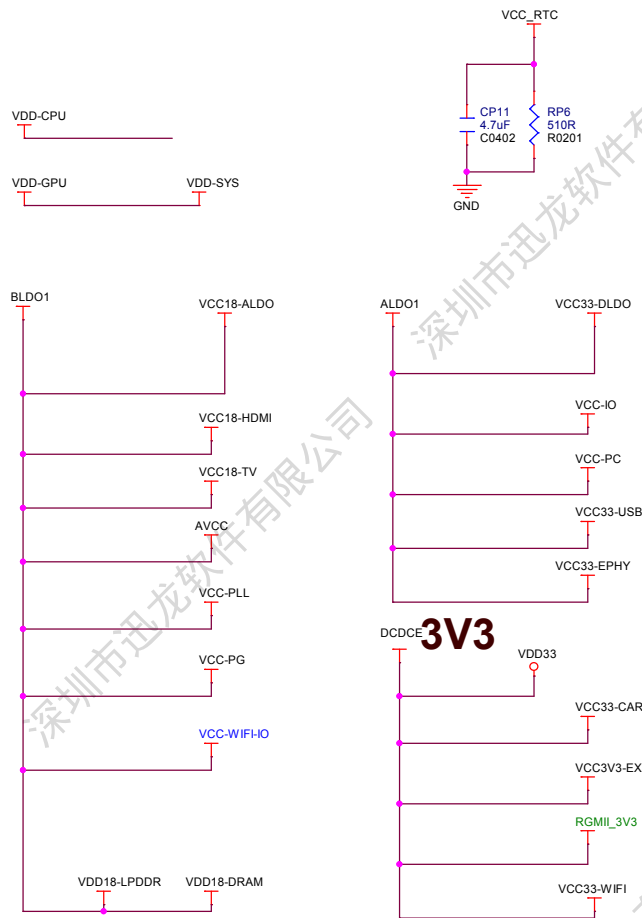



 Xunlong Software Co., Limited Design Name ORANGEPI Zero 2W			
			Size A3
Date:	Tuesday, September 26, 2023	Sheet	4 of 7

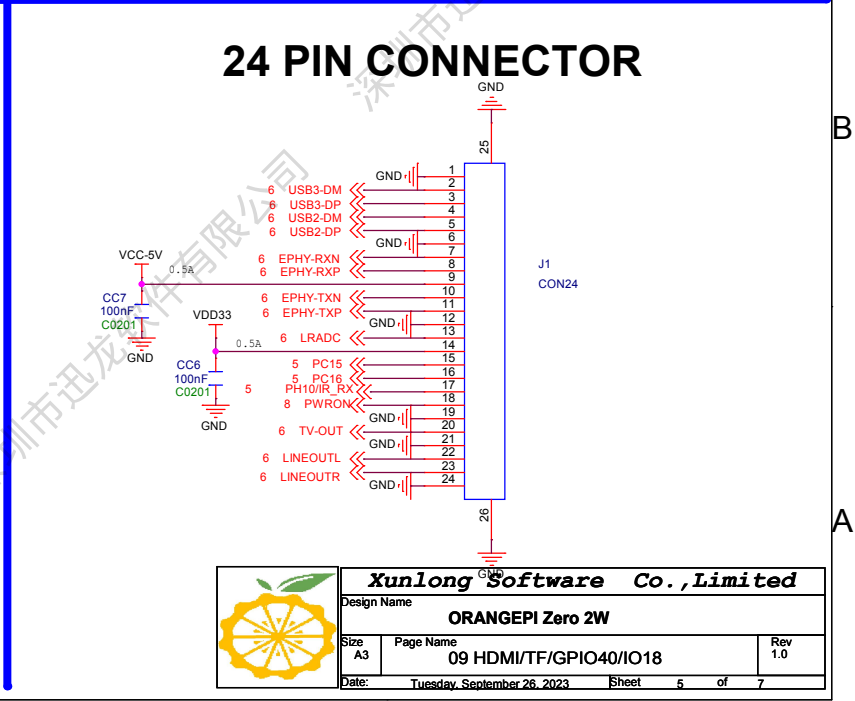
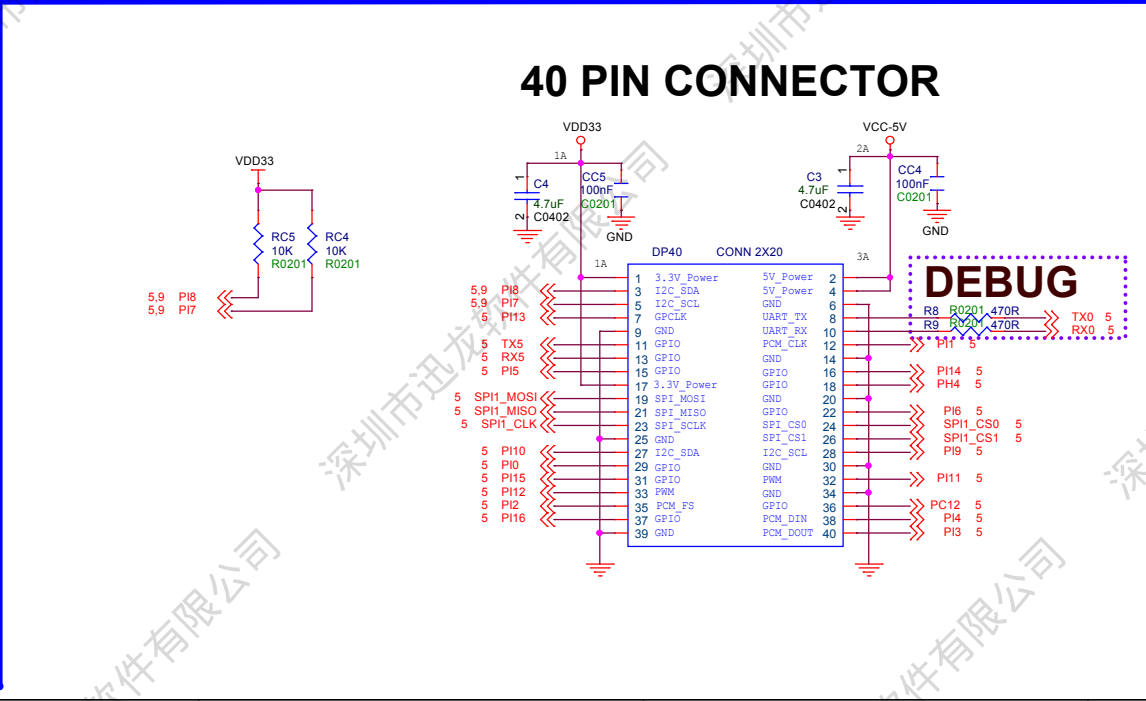
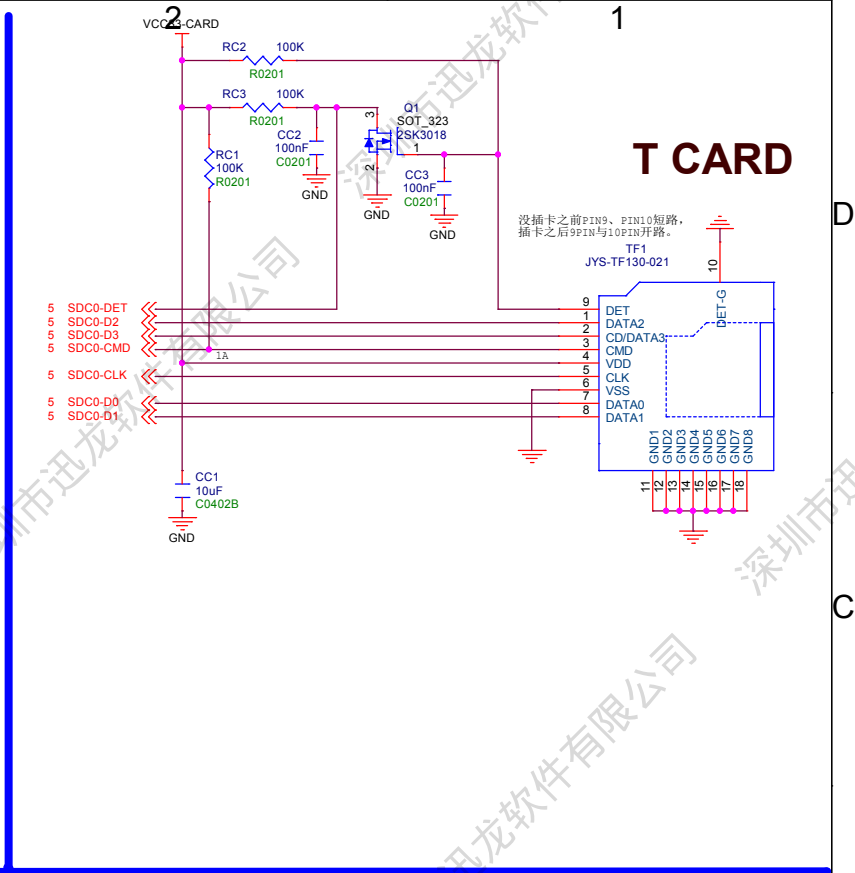
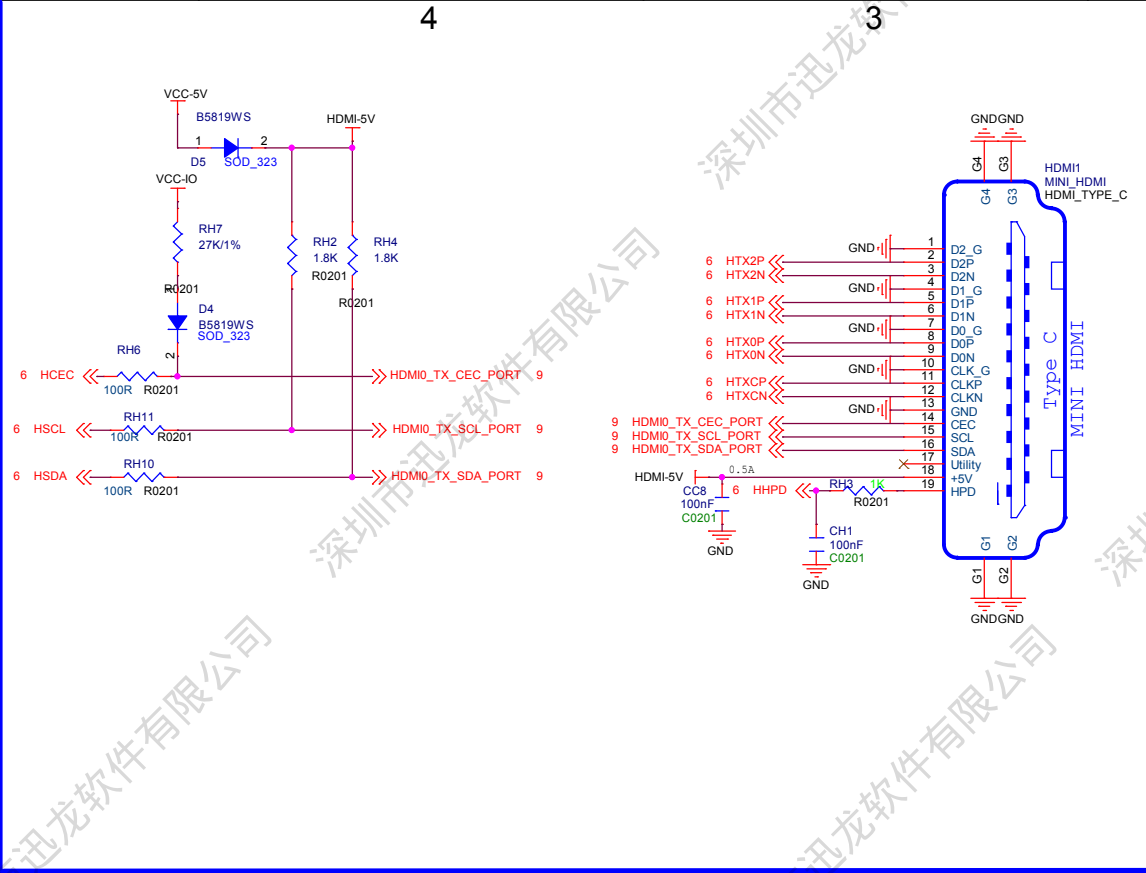

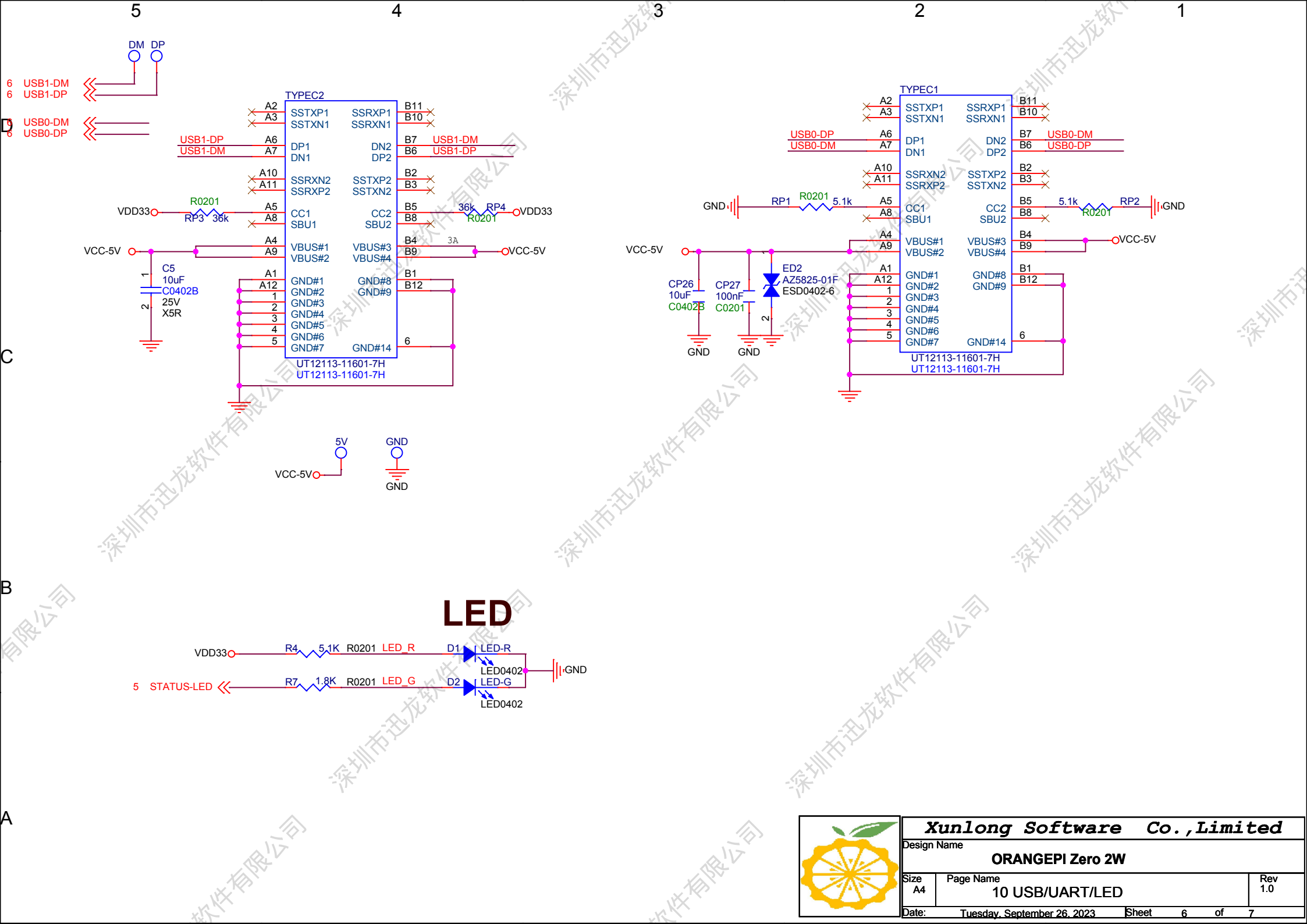

Xunlong Software Co., Limited		
Design Name		
ORANGEPI Zero 2W		
Size	Page Name	Rev
A4	10 USB/UART/LED	1.0
Date:	Tuesday, September 26, 2023	Sheet 6 of 7

WIFI+BT

