

### 1. General Description

The WP25101T5-B is a current limited P-channel MOSFET power switch designed for high-side load switching applications. This switch operates with inputs ranging from 2.5V to 5.5V, making it ideal for both 3.3V and 5V systems. An integrated current-limiting circuit protects the input supply against large currents which may cause the supply to fall out of regulation. The WP25101T5-B includes thermal shutdown protection that prevents damage to the device when a continuous over-current condition causes excessive heating by turning off the switch. The load of the switch can be up to 1A. The quiescent current is only 28µA in active mode while it is less than 1µA in shutdown mode. Fault flag ( $\overline{\text{FLT}}$ ) can indicate over current and fault conditions.

The WP25101T5-B is available in Pb-free packages and is characterized for operation over the free-air temperature range of - 40°C to 85°C.

### 2. Features

- Input Voltage Range: 2.5V to 5.5V
- 1.5A Current Limit
- Reverse Current Blocking

- Short-Circuit Response: 2µs
- Very Low Quiescent Current: 28µA (Typ.)
- 1µA Max Shutdown Supply Current
- Fault Flag ( $\overline{\text{FLT}}$ ) output for over current and fault conditions.
- Built-in Pull-up Resistor for EN Pin
- Automatic Output Discharge at Shutdown
- Under-Voltage Lockout
- Thermal Shutdown
- 8kV ESD Rating
- Package: SOT23-5

### 3. Applications

- Laptop/Desktop Computers and Netbooks
- 3G Wireless Cards
- Smart Phones and PDAs
- LCD TVs and Monitors
- Set-Top-Boxes
- MP3/MP4
- Printers
- Portable Game Players
- Portable Media Players and MIDs
- USB Keyboards
- USB Hard Disk Drives
- USB Memory Drives
- USB Hubs

### 4. Typical Application

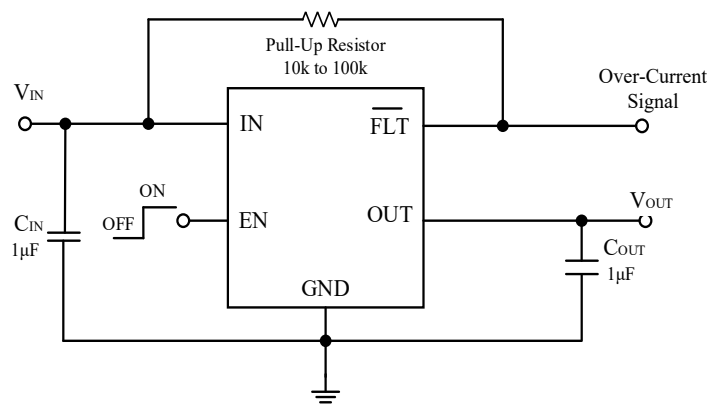

**Note:** Tantalum or Aluminum Electrolytic capacitors ( $C_{IN}$  and  $C_{OUT}$ ) may be required for USB applications.

### 5. Pin Configuration

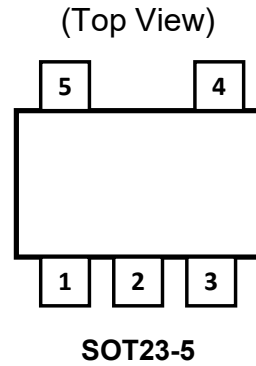

### 6. Pin Description

| PIN NUMBER | PIN NAME                | I/O | PIN FUNCTION   |
|------------|-------------------------|-----|--|
| 1          | OUT                     | O   | Switch output.   |
| 2          | GND                     |     | Common ground.   |
| 3          | $\overline{\text{FLT}}$ | O   | Fault FLAG output. Open drain output that indicates an over current, supply under voltage or over temperature state. |
| 4          | EN                      | I   | Enable input. Active High.   |
| 5          | IN                      | I   | Switch input.  |

### 7. Absolute Maximum Ratings

Over operating free-air temperature range (unless otherwise noted)<sup>[1]</sup>

| PARAMETER  | RATING                        | UNIT                        |
|--|-------------------------------|-----------------------------|
| IN, EN, $\overline{\text{FLT}}$ Voltage            | -0.3 to 6                     | V                           |
| OUT Voltage  | -0.3 to $V_{\text{IN}} + 0.3$ | V                           |
| OUT Current  | Internal Limited              | A                           |
| Power Dissipation                                  | 400                           | mW                          |
| Package Thermal Resistance( $\theta_{\text{JA}}$ ) | 250                           | $^{\circ}\text{C}/\text{W}$ |
| Operating Junction Temperature                     | -40 to 125                    | $^{\circ}\text{C}$          |
| Storage Temperature                                | -55 to 150                    | $^{\circ}\text{C}$          |
| Lead Temperature (Soldering, 10 sec)               | 260                           | $^{\circ}\text{C}$          |
| ESD(HBM)   | 8000                          | V                           |

**NOTE1:** Stresses beyond those listed under Absolute Maximum Ratings may cause permanent damage to the device. These are stress ratings only, which do not imply functional operation of the device at these or any other conditions beyond those indicated under Recommended Operating Conditions. Exposure to absolute-maximum-rated conditions for extended periods may affect device reliability.

### 8. Recommended Operating Conditions

| SYMBOL           | PARAMETER                     | MIN | MAX | UNIT               |
|------------------|-------------------------------|-----|-----|--------------------|
| $V_{\text{IN}}$  | Input Voltage                 | 2.5 | 5.5 | V                  |
| $I_{\text{OUT}}$ | Output Current                |     | 1   | A                  |
| $T_{\text{A}}$   | Operating Ambient Temperature | -40 | 85  | $^{\circ}\text{C}$ |

### 9. Electrical Characteristics

( $V_{IN} = 5\text{ V}$ ,  $V_{EN} = 5\text{ V}$ ,  $C_{IN}=1\mu\text{F}$ ,  $C_{OUT}=1\mu\text{F}$ ,  $T_A=25^\circ\text{C}$ , unless otherwise noted)

| SYMBOL                      | PARAMETER                       | TEST CONDITIONS   | MIN | TYP.  | MAX | UNIT             |
|-----------------------------|---------------------------------|---|-----|-------|-----|------------------|
| $I_{SHDN}$                  | Shutdown Quiescent Current      | Disabled, OUT floating or shorted to ground                             |     | 0.3   | 1   | $\mu\text{A}$    |
| $I_Q$                       | Quiescent Current               | Enabled, OUT floating   |     | 28    | 60  | $\mu\text{A}$    |
| $R_{DS(ON)}$                | Switch on-resistance            | $V_{IN}=5\text{V}$ , $I_{OUT}=1\text{A}$                                |     | 70    | 120 | $\text{m}\Omega$ |
| $I_{LIM}$                   | Current Limit                   | $V_{IN}=5\text{V}$ , $V_{OUT}=4.5\text{V}$                              | 1.2 | 1.5   | 1.8 | A                |
| $V_{IL}$                    | EN Input Logic-Low Voltage      | Note 2  |     |       | 0.5 | V                |
| $V_{IH}$                    | EN Input Logic-High Voltage     | Note 2  | 1.5 |       |     | V                |
| $R_{\overline{FLT}}$        | $\overline{FLT}$ Low Resistance | Note 3  |     | 80    |     | $\Omega$         |
| $t_{\overline{FLT\_DELAY}}$ | $\overline{FLT}$ Delay Time     | Note 3  |     | 15    |     | ms               |
| $I_{SINK}$                  | EN Input leakage                | $V_{EN} = 5\text{V}$  |     | 0.01  | 1   | $\mu\text{A}$    |
|                             |                                 | $V_{EN} = 0\text{V}$  | -2  | -0.25 |     | $\mu\text{A}$    |
| $V_{UVLO}$                  | Input UVLO Threshold            | Enabled, $V_{IN}$ rising  | 1.4 | 1.8   | 2.2 | V                |
| $V_{UVLO\_HYS}$             | Input UVLO Hysteresis           |   |     | 0.1   |     | V                |
| $I_{REV}$                   | Reverse Leakage Current         | $V_{IN} = 0\text{V}$ , $V_{OUT} = 5\text{V}$ ,<br>$I_{REV}$ at $V_{IN}$ |     | 0.1   | 1   | $\mu\text{A}$    |
| $t_{ON}$                    | Output Turn-on Delay Time       | $R_{LOAD}=100\Omega$  | 0.2 | 0.5   | 1   | ms               |
| $t_R$                       | Output Turn-on Rise Time        | $R_{LOAD}=100\Omega$  | 0.2 | 0.4   | 0.8 | ms               |
| $t_{OFF}$                   | Output Turn-off Delay Time      | $R_{LOAD}=100\Omega$  | 0.2 | 0.5   | 0.8 | ms               |
| $t_F$                       | Output Turn-off Fall Time       | $R_{LOAD}=100\Omega$  | 100 | 350   | 500 | $\mu\text{s}$    |
| $R_{DIS}$                   | Output Discharge Resistance     | Disabled, $V_{IN} = 5\text{V}$ , $V_{OUT}=1\text{V}$ ,                  | 50  | 120   | 350 | $\Omega$         |
| $T_{SHDN}$                  | Thermal Shutdown Threshold      | Note 3  |     | 150   |     | $^\circ\text{C}$ |
| $T_{HYS}$                   | Thermal shutdown hysteresis     | Note 3  |     | 20    |     | $^\circ\text{C}$ |

**Note2:** EN includes a small pull-up current source, nominally 0.1 $\mu\text{A}$ . When EN pin is floating, the chip is enabled.

**Note3:** Guaranteed by design.

### 10. Typical Performance Characteristics

( $V_{IN} = 5V$ ,  $V_{EN} = 5V$ ,  $C_{IN} = 1\mu F$ ,  $C_{OUT} = 1\mu F$ ,  $T_A = 25^\circ C$ , unless otherwise noted)

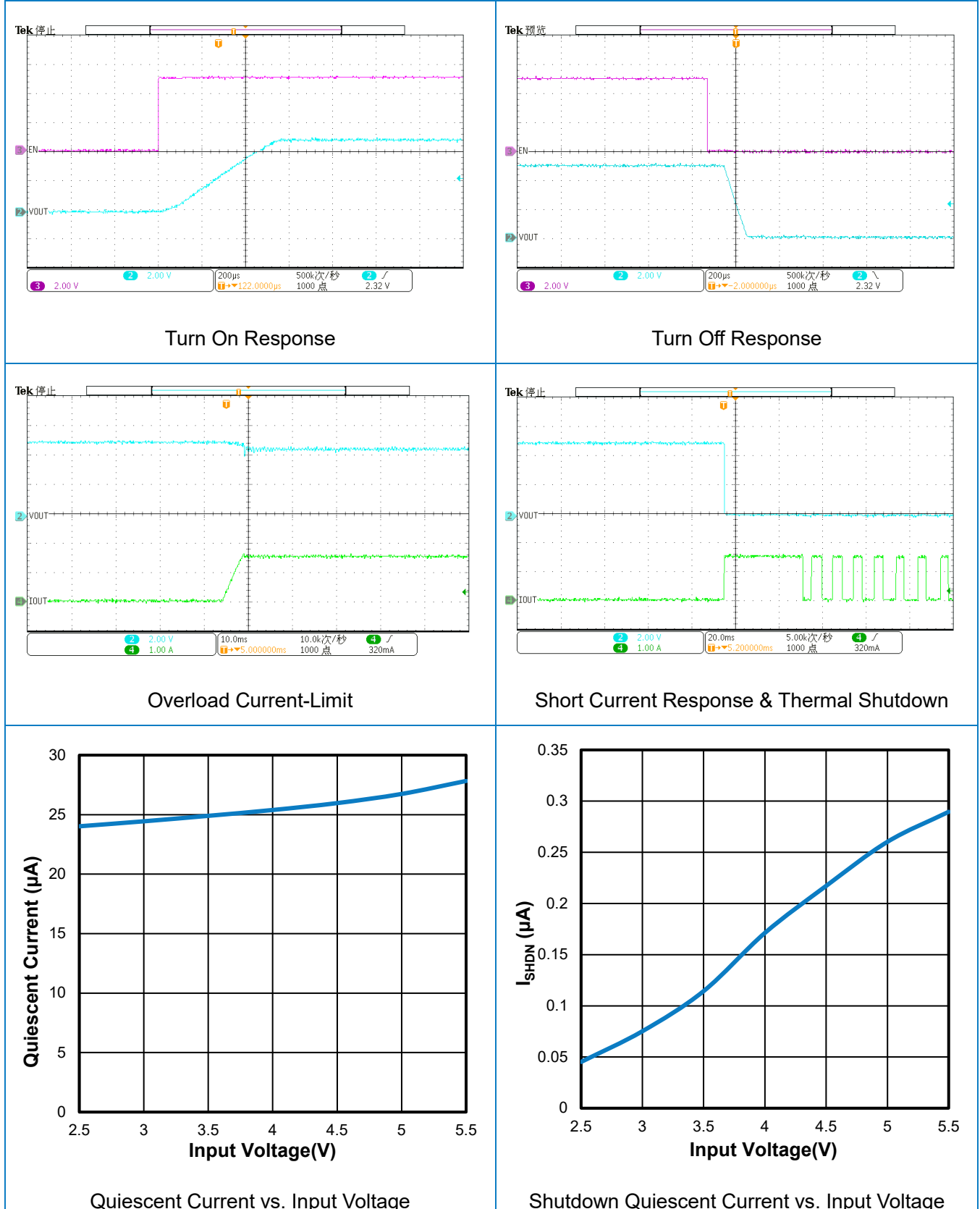

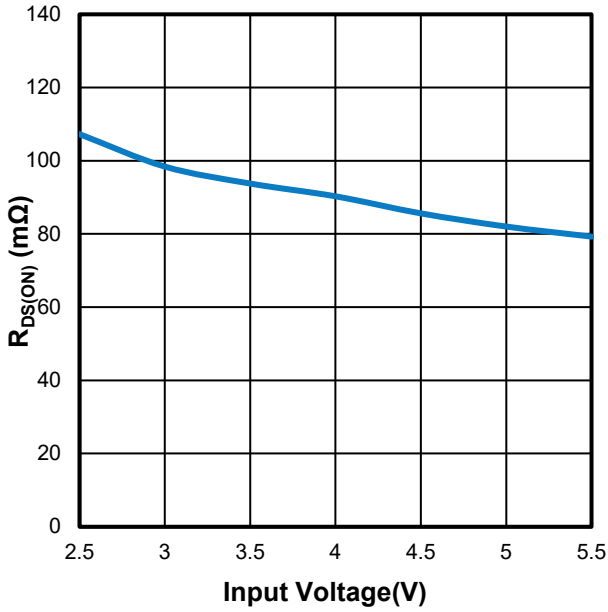

Switch On-Resistance vs. Input Voltage

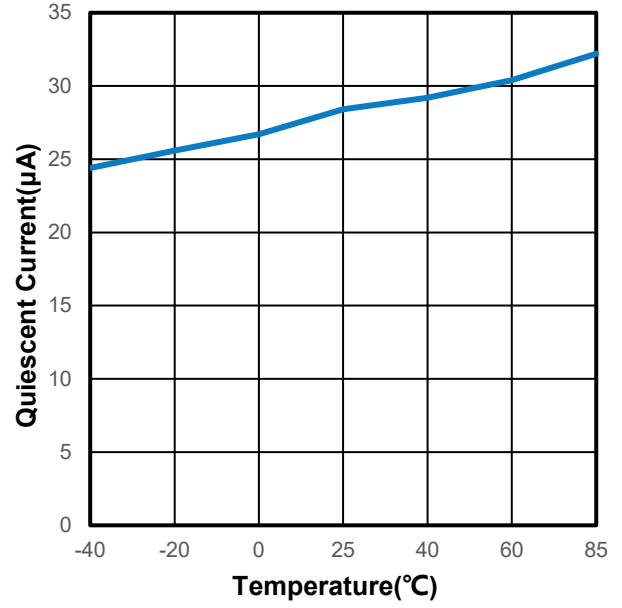

Quiescent Current vs. Ambient Temperature

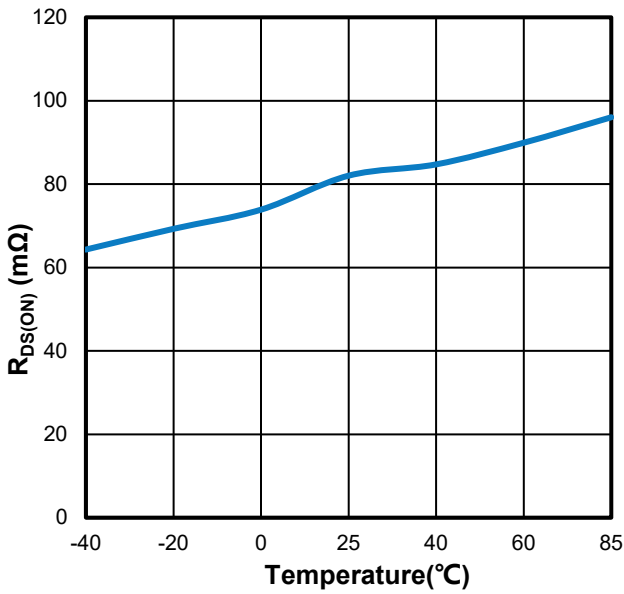

Switch On-Resistance vs. Ambient Temperature

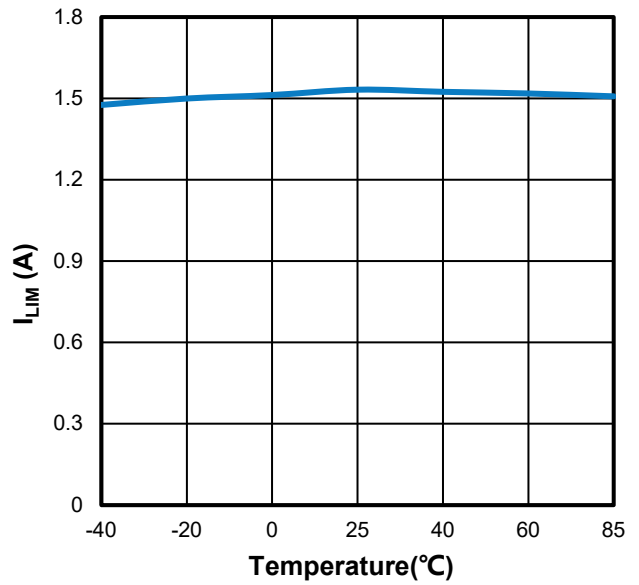

Current Limit vs. Ambient Temperature

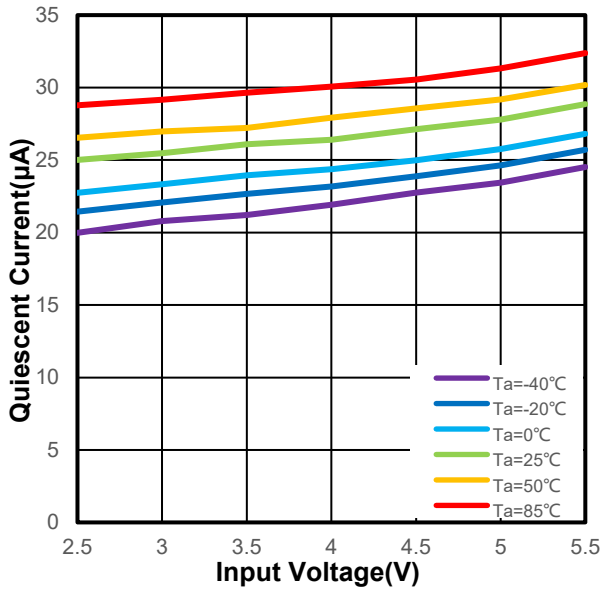

Quiescent Current vs. Input Voltage vs. Ambient Temperature

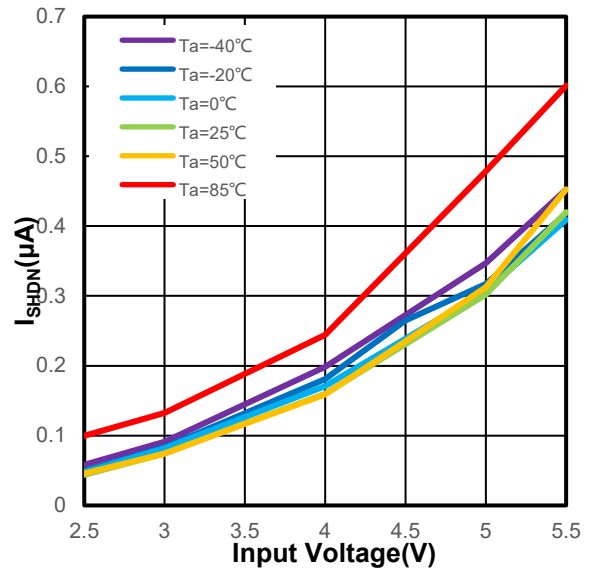

Shutdown Quiescent Current vs. Input Voltage vs. Ambient Temperature

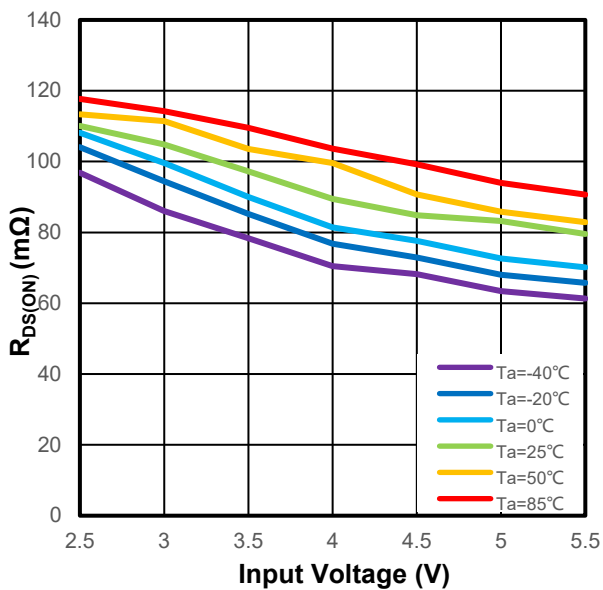

Switch On-Resistance vs. Input Voltage vs. Ambient Temperature

## 11. Function Description

### 11.1 Overview

The WP25101T5-B load switches are 5.5V, current limited load switches in a SOT23-5 package. The devices contain a 70 mΩ current-limited P-channel MOSFET that can operate over an input voltage range of 2.5 V to 5.5V. When the switch current reaches the maximum limit, the WP25101T5-B operates in a constant-current mode to prohibit excessive currents from causing damage. WP25101T5-B has a current limit of 1.5 A.

### 11.2 Block Diagram

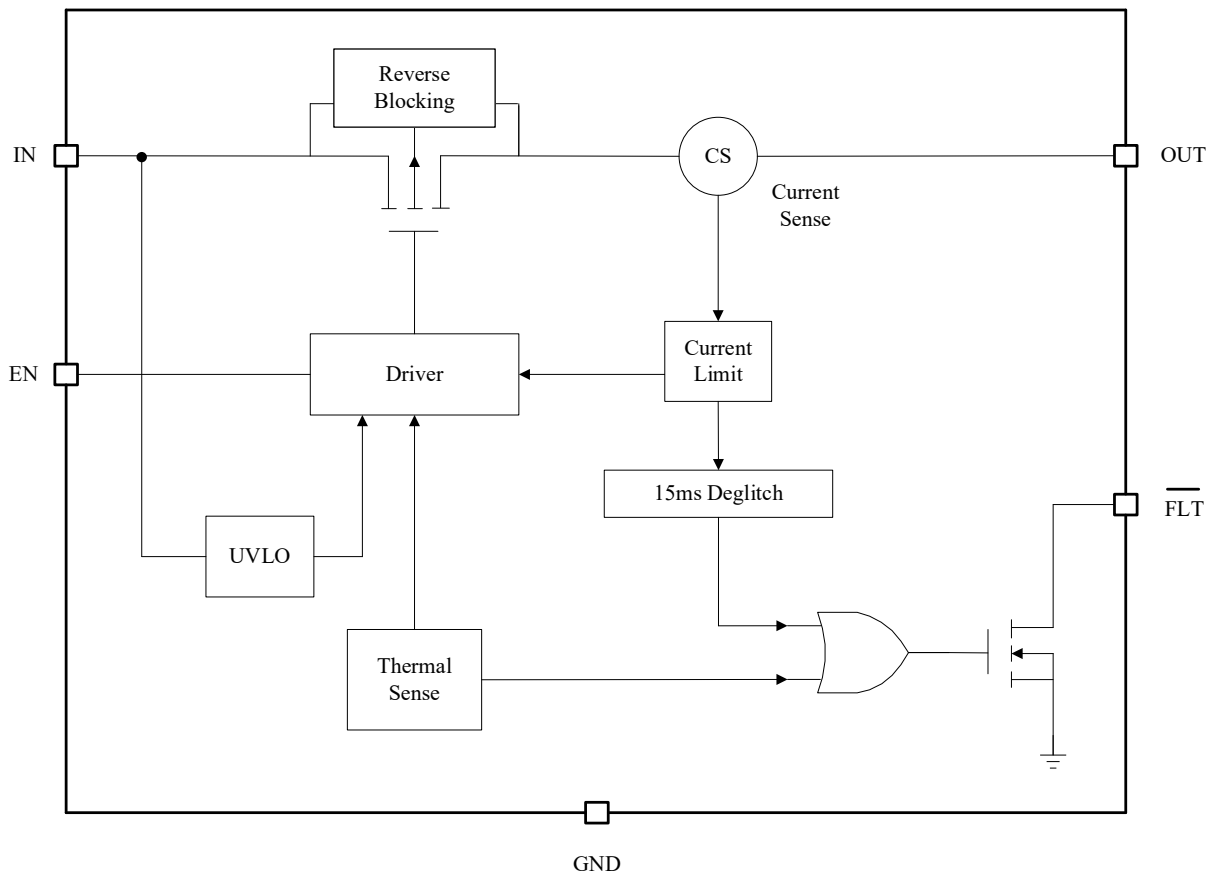

### 11.3 Feature Description

#### 11.3.1 Current Limiting

When the switch current reaches the maximum limit, the WP25101T5-B operates in a constant-current mode to prohibit excessive currents from causing damage.

#### 11.3.2 Fault Reporting

The Fault flag ( $\overline{\text{FLT}}$ ) can indicate over current condition. Fault flag is an open drain signal and must be pulled up by a pull-up resistor. Fault flag is logic high in normal. When over current occurs, fault flag change to logic low with a duration of at least 8 ms after about 15ms delay which is guaranteed by design. Therefore fault flag is a negative pulse signal, not a level signal. A heavy load may cause a momentary over current condition, however, no false reporting occurs on  $\overline{\text{FLT}}$  due to the 15ms deglitch circuits.



### 11.3.3 Thermal Shutdown

Thermal shutdown protects the device from internally or externally generated excessive temperatures. During an overtemperature condition the switch is turned off. The switch automatically turns on again if the temperature of the die drops below the threshold temperature.

### 11.3.4 Quick Output Discharge

The WP25101T5-B include the Quick Output Discharge (QOD) feature, in order to discharge the application capacitor connected on OUT pin.

## 11.4 Device Functional Modes

When the EN pin is actively pulled high and no fault conditions are present, the switch will be turned on, connecting  $V_{IN}$  to  $V_{OUT}$ . When the EN pin is actively pulled low regardless of the fault condition, the switch will be turned off. In the event that the current limit is exceeded, the device will operate in a constant-current mode until the fault condition is removed. During thermal shutdown conditions, the switch will automatically turn off and will turn back on again if the temperature of the die drops below the threshold temperature.

## 12. Application and Implementation

---

### 12.1 Application Information

#### 12.1.1 EN Control

The EN pin controls the state of the switch. Activating EN continuously holds the switch in the on state as long as there is no fault. An undervoltage lockout or thermal shutdown event will override the EN pin control and turn off the switch. EN is active high and has a low threshold, making it capable of interfacing with low-voltage signals.

#### 12.1.2 Input Capacitor

To limit the voltage drop on the input supply caused by transient inrush current, a capacitor 1 $\mu$ F or larger must be placed between the IN and GND pins.

#### 12.1.3 Output Capacitor

A 1 $\mu$ F or larger capacitor should be placed between the OUT and GND pins. This capacitor will prevent parasitic board inductances from forcing OUT below GND when the switch turns off.

#### 12.1.4 Undervoltage Lockout

The undervoltage lockout turns off the switch if the input voltage drops below the undervoltage lockout threshold. Under-voltage detection functions only when the switch is enabled.

#### 12.1.5 Power Dissipation and Junction Temperature

The junction temperature of the switch depend on several factors such as the load, PCB layout, ambient temperature and package type. Power dissipation can be calculated based on the output current and the  $R_{DS(ON)}$  of the switch as below.

$$P_D = R_{DS(ON)} \times I^2$$

The junction temperature can be estimated by the following thermal equation:

$$T_J = P_D \times \theta_{JA} + T_A$$

Where:

- $T_A$  = Ambient temperature
- $\theta_{JA}$  = Thermal resistance
- $P_D$  = Total power dissipation

With all possible conditions, the junction temperature must be within the range specified under operating conditions. The maximum output current must be derated at higher ambient temperature to ensure the junction temperature does not exceed the maximum junction temperature which is 125°C.

### 13. Power Supply Recommendations

The device is designed to operate from a  $V_{IN}$  range of 2.5 V to 5.5 V. This supply must be well regulated and placed as close to the device terminal as possible with the recommended 1µF bypass capacitor. If the supply is located more than a few inches from the device terminals, additional bulk capacitance may be required in addition to the ceramic bypass capacitors. If additional bulk capacitance is required, an electrolytic, tantalum, or ceramic capacitor of 10 µF may be sufficient

### 14. Layout

For best performance, all traces should be as short as possible, the input and output capacitors should be placed close to the device to minimize the effects that parasitic trace inductances may have on normal and short-circuit operation. The  $V_{IN}$  terminal should be bypassed to ground with low ESR ceramic bypass capacitors. The typical recommended bypass capacitance is 1µF ceramic with X5R or X7R dielectric. This capacitor should be placed as close to the device terminals as possible. Using wide traces for  $V_{IN}$ ,  $V_{OUT}$ , and GND will help minimize parasitic electrical effects along with minimizing the case to ambient thermal impedance.

#### 14.1 Layout Example

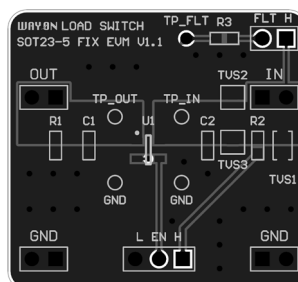

### 15. Evaluation Modules

Evaluation Modules (EVMs) are available to help evaluate the device performance. We have evaluation modules for different packages, you can contact us by phone or address at the end to get the evaluation module or schematic.

The module names are listed in the table below.

| NAME        | PACKAGE | EVALUATION MODULE                      |
|-------------|---------|--|
| WP25101T5-B | SOT23-5 | WAYON LOAD SWITCH SOT23-5 FIX EVM V1.1 |

### 16. Naming Conventions

#### WP AB CCC D EE - F

- WP:** WAYON Protection IC;
- A:** Product Category –2: Load Switch;
- B:** Maximum Output Voltage – 5: <6V;
- CCC:** Maximum Output Current –10: 1A;
- D:** Serial number;
- EE:** Package – T5: SOT23-5
- F:** Current Limit Accuracy – B: 20%

**17. Package Information**

**SOT 23-5**

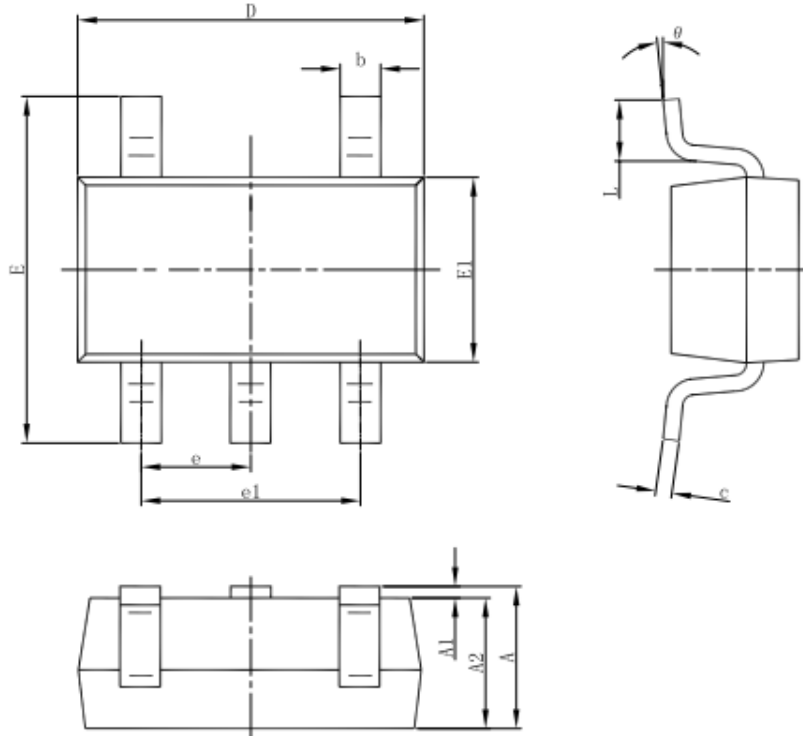

| SYMBOL       | DIMENSIONS IN MILLIMETERS |       |       |
|--------------|---------------------------|-------|-------|
|              | MIN                       | NOM   | MAX   |
| <b>A</b>     | 1.000                     | 1.175 | 1.350 |
| <b>A1</b>    | 0.000                     | 0.075 | 0.150 |
| <b>A2</b>    | 1.000                     | 1.100 | 1.200 |
| <b>b</b>     | 0.300                     | 0.400 | 0.500 |
| <b>c</b>     | 0.100                     | 0.150 | 0.200 |
| <b>D</b>     | 2.820                     | 2.920 | 3.020 |
| <b>E1</b>    | 1.500                     | 1.600 | 1.700 |
| <b>E</b>     | 2.600                     | 2.800 | 3.000 |
| <b>e</b>     | 0.950(BSC)                |       |       |
| <b>e1</b>    | 1.800                     | 1.900 | 2.000 |
| <b>L</b>     | 0.300                     | 0.450 | 0.600 |
| <b>theta</b> | 0°                        | 4°    | 8°    |

**18. Ordering Information**

| <b>PART NUMBER</b> | <b>CURRENT LIMIT</b> | <b>PACKAGE</b> | <b>PACKING QUANTITY</b> | <b>MARKING*</b> |
|--------------------|----------------------|----------------|-------------------------|-----------------|
| WP25101T5-B        | 1.5A                 | SOT23-5        | 3k/Reel                 | 25101 BXXXX     |

\* XXXX is variable.

### **STATEMENTS**

WAY-ON provides data sheets based on the actual performance of the device, and users should verify actual device performance in their specific applications. The device characteristics and parameters in this data sheet can and do vary from application to application, and actual device performance may change over time. This information is intended for developers designing with WAY-ON products. Users are responsible for selecting the appropriate WAY-ON product for their application and for designing and verifying the application to ensure that your application meets the appropriate standards or other requirements, and users are responsible for all consequences. Specifications are subject to change without notice.

### **Contact Information**

No.1001, Shiwan(7) Road, Pudong District, Shanghai, P.R.China.201202

Tel: 86-21-68960674 Fax: 86-21-50757680 Email: [market@way-on.com](mailto:market@way-on.com)

WAYON website: <http://www.way-on.com>

For additional information, please contact your local Sales Representative.

**WAYON**® is registered trademark of Wayon Corporation.

*Specifications are subject to change without notice.*

*The device characteristics and parameters in this data sheet can and do vary in different applications and actual device performance may vary over time.*

*Users should verify actual device performance in their specific applications.*