

1.5 μ A Low Iq, 300mA Low Noise LDO Regulator

Features

- 1.5 μ A Quiescent Current Typically
- 70dB PSRR at 1kHz
- Up to 300mA Output Current
- Low Shutdown Current: <0.1 μ A
- Output Voltage Accuracy: \pm 2%
- Output Current Limit Protection
- Fixed Output Voltage 1.2V, 1.5V, 1.8V, 2.5V, 2.8V, 3.0V, 3.3V.
- Stable with Ceramic Output Capacitors
- Thermal Shutdown
- Output Auto-Discharge in EN Shutdown
- Available in SOT23-5 Package

Description

The TMI6038 is a low-dropout regulator with fixed output voltage 1.2V, 1.5V, 1.8V, 2.5V, 2.8V, 3.0V, 3.3V. It provides up to 300mA output current with input voltage range from 1.7V to 5.5V. It has 1.5 μ A very low quiescent current and is suitable for battery powered equipment with longer application life. TMI6038 is designed to work with low ESR ceramic capacitors to reduce the amount of the PCB area. The TMI6038 is available in a SOT23-5 RoHS compliant package.

Application

- IP Camera
- Wearable Devices
- Battery Powered Equipment

Typical Application

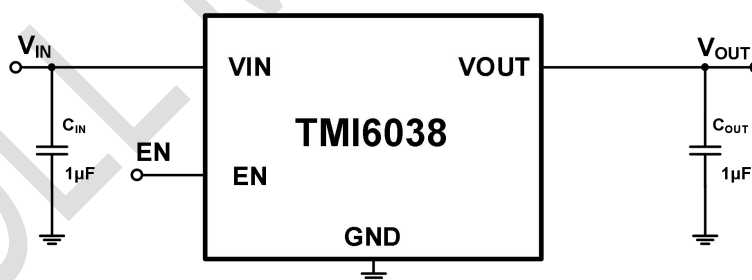
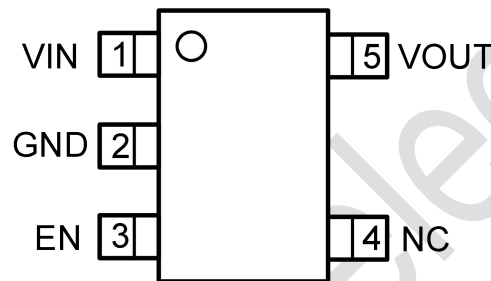

Figure 1. TMI6038 fixed output Circuit

Absolute Maximum Ratings (Note 1)

| Parameter | Min | Max | Unit |
|-----------------------------------|------|-----------------|------|
| Input Supply Voltage and EN | -0.3 | 6.5 | V |
| All Other Pins Voltage | -0.3 | V _{IN} | V |
| Storage Temperature Range | -65 | 150 | °C |
| Junction Temperature (Note2) | - | 150 | °C |
| Power Dissipation | - | 600 | mW |
| Lead Temperature (Soldering, 10s) | - | 260 | °C |

Package



Top View
SOT23-5

Order Information

| Part Number | Package | Top Marking | Quantity/Reel |
|-------------|---------|-------------|---------------|
| TMI6038-12 | SOT23-5 | T6Bxxx | 3000 |
| TMI6038-15 | SOT23-5 | T6Cxxx | 3000 |
| TMI6038-18 | SOT23-5 | T6Dxxx | 3000 |
| TMI6038-25 | SOT23-5 | T6Exxx | 3000 |
| TMI6038-28 | SOT23-5 | T6Fxxx | 3000 |
| TMI6038-30 | SOT23-5 | T6Gxxx | 3000 |
| TMI6038-33 | SOT23-5 | T6Hxxx | 3000 |

TMI6038-XX devices are Pb-free and RoHS compliant.

Pin Functions

| Pin | Name | Function |
|-----|------|--|
| 1 | VIN | Input Supply of the LDO. |
| 2 | GND | Signal Ground. |
| 3 | EN | Enable Pin. Connect this pin to ground or less than 0.4V to disable the device, connect EN to 1.5V or above to enable the device. This pin should not be floated. |
| 4 | NC | No connection |
| 5 | VOUT | Output of the LDO |

ESD Rating

| Items | Description | Value | Unit |
|----------------|-----------------------------------|------------|------|
| V_{ESD_HBM} | Human Body Model for all pins | ± 2000 | V |
| V_{ESD_CDM} | Charged Device Model for all pins | ± 1000 | V |

JEDEC specification JS-001

Recommended Operating Conditions

| Items | Description | Min | Max | Unit |
|---------------|--------------------------------|-----|-----|--------------------|
| Voltage Range | IN | 1.7 | 5.5 | V |
| T_J | Operating Junction Temperature | -40 | 125 | $^{\circ}\text{C}$ |
| T_A | Operating Ambient Temperature | -40 | 125 | $^{\circ}\text{C}$ |

Thermal Resistance (Note3)

| Items | Description | Value | Unit |
|---------------|--|-------|-----------------------------|
| θ_{JA} | Junction-to-ambient thermal resistance | 168 | $^{\circ}\text{C}/\text{W}$ |
| θ_{JC} | Junction-to-case(top) thermal resistance | 62 | $^{\circ}\text{C}/\text{W}$ |
| ψ_{JC} | Junction-to-case(top) characterization parameter | 18 | $^{\circ}\text{C}/\text{W}$ |

Electrical Characteristics

$V_{IN}=V_{OUT}+1V$ or $V_{IN}=2.5V$ (whichever is greater), $T_A = 25^{\circ}C$, unless otherwise noted.

| Symbol | Parameter | Conditions | Min | Typ | Max | Units |
|-----------------------|---|---|------|------|-----|---------------|
| Input Voltage | | | | | | |
| V_{IN} | Input Voltage Range (Note 4) | | 1.7 | | 5.5 | V |
| I_q | Quiescent Current | $V_{EN}=2V$, No load | 0.5 | 1.5 | 3.5 | μA |
| I_{SD} | Shutdown Current | $V_{IN}=5V$, $V_{EN}=0V$ | | | 0.1 | μA |
| PSRR | Power Supply Ripple Rejection | $V_{IN}=3.3V$, $V_{OUT}=2.8V$, $I_{OUT}=10mA$ | | 70 | | dB |
| Enable | | | | | | |
| V_{EN_H} | Enable Input High Voltage | | 1.5 | | | V |
| V_{EN_L} | Enable Input Low Voltage | | | | 0.4 | V |
| I_{EN} | EN Input Current | $V_{EN}=V_{IN}=5V$ | -0.1 | | 0.1 | μA |
| Output Voltage | | | | | | |
| $V_{OUT\%}$ | Output Voltage Accuracy | $V_{IN}=V_{OUT}+1V$, $I_{OUT}=10mA$ | -2 | | 2 | % |
| V_{LNR} | Output Line Regulation | $V_{OUT}+0.5V < V_{IN} < 5.5V$, $I_{OUT}=10mA$ | | 0.01 | | %/V |
| V_{LDR} | Output Load Regulation | $1mA < I_{OUT} < 300mA$, $V_{IN}=V_{NOM}+1.0V$ | | 3 | | mV |
| V_{DROP} | Dropout Voltage (Note 5) at $I_{OUT}=300mA$ | $V_{OUT}=1.2V$ | | 1300 | | mV |
| | | $V_{OUT}=2.5V$ | | 600 | | mV |
| | | $V_{OUT}=3.3V$ | | 520 | | mV |
| V_{NOISE} | Output Noise Voltage | BW=20Hz to 20kHz, $V_{IN}=3.3V$, $V_{OUT}=2.8V$, $I_{OUT}=10mA$ | | 50 | | μV_{RMS} |
| I_{OUTMAX} | Maximum Output Current | | 300 | | | mA |
| R_{DIS} | Resistance of Auto-Discharge | | | 100 | | Ω |
| Protection | | | | | | |
| I_{LIMIT} | Output Current Limit | $V_{OUT} = 90\% V_{NOR}$ | 350 | 600 | | mA |
| T_{SD} | Thermal Shutdown Temperature (Note 6) | | | 160 | | $^{\circ}C$ |
| T_{SDHYS} | Thermal Shutdown Hysteresis (Note 6) | | | 20 | | $^{\circ}C$ |

Note 1: Absolute Maximum Ratings are those values beyond which the life of a device may be impaired.

Note 2: T_J is calculated from the ambient temperature T_A and power dissipation P_D according to the following formula: $T_J = T_A + P_D \times \theta_{JA}$.

Note 3: Measured on JESD51-7, 4-layer PCB.

Note 4: The load condition and dropout voltage should be considered in low input voltage application to ensure input voltage have enough headroom for expected load current.

Note 5: The dropout voltage is defined as $V_{IN}-V_{OUT}$, when V_{OUT} is 98% of the normal value of V_{OUT} .

Note 6: Guaranteed by design.

Block Diagram

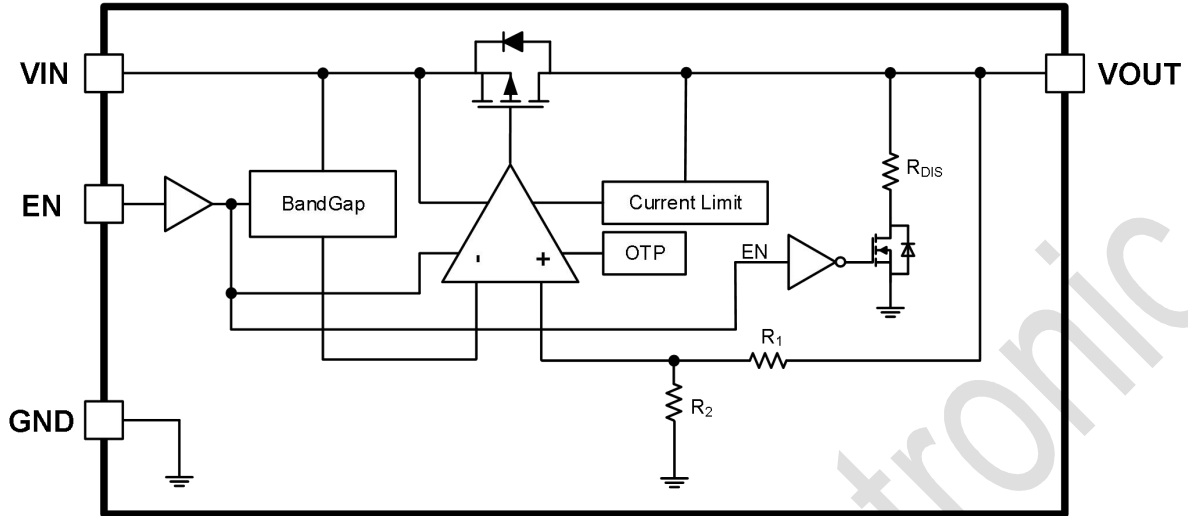
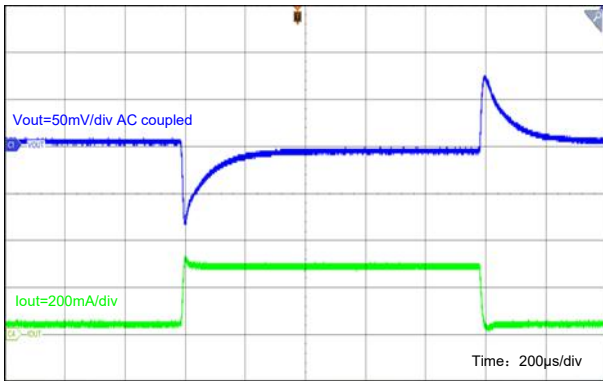

Figure 1. TMI6038-XX Block Diagram

TYPICAL PERFORMANCE CHARACTERISTICS

Load Transient

Vin=3.8V, Vo=2.8V, Io=10mA to 300mA



EN Start up

Vin=3.8V, EN=3.8V, Vout=2.8V, TA=25°C



Over Temperature Protection

Vin=3.8V, Vo=2.8V, Ro=3Ω

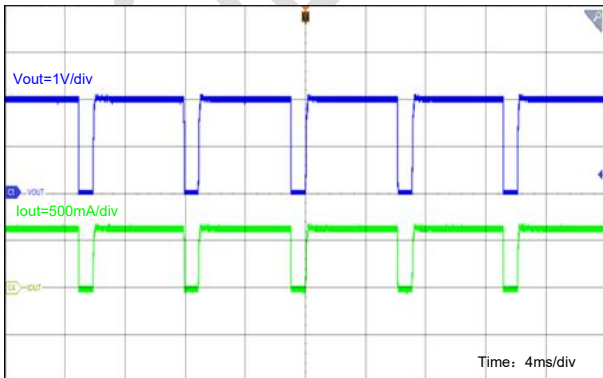

Dropout vs. Iout

Vin=3.8V, Vout=3.8V, TA=25°C

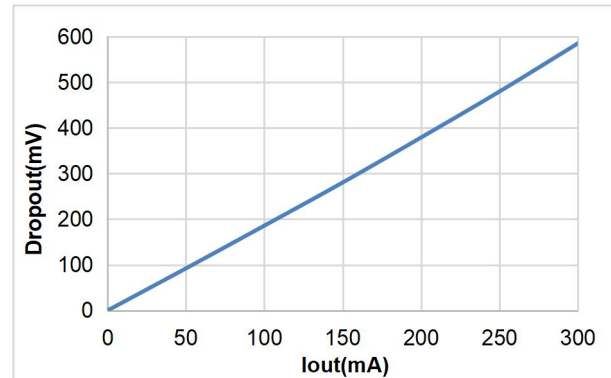

PSRR vs Frequency

$V_{in}=3.3V$, $V_o=1.8V$, $I_o=10mA$, $T_A=25^{\circ}C$

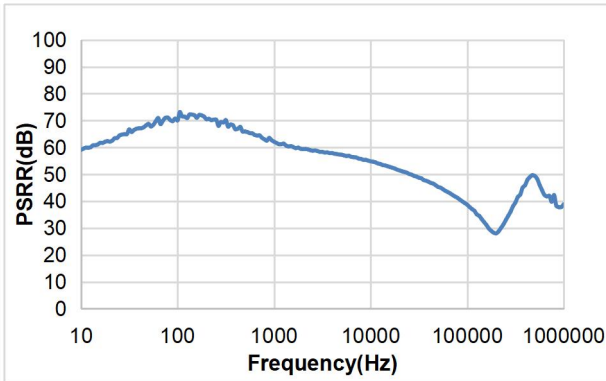

PSRR vs Frequency

$V_{in}=5.0V$, $V_o=3.3V$, $I_o=10mA$, $T_A=25^{\circ}C$

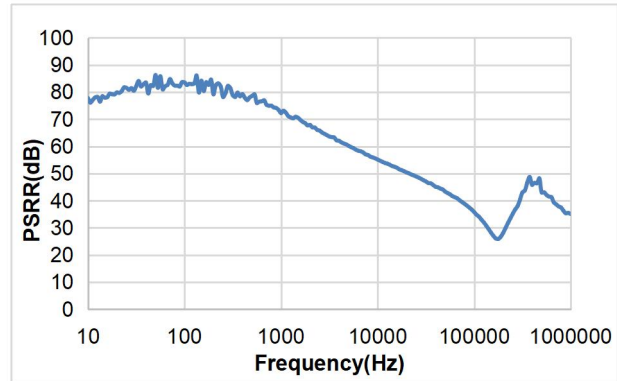

Operation Description

Overview

The TMI6038 is a low quiescent current, 300mA output current, low dropout linear regulator with high PSRR and low Noise performance. TMI6038 provide fixed output voltage with 1.2V, 1.5V, 1.8V, 2.5V, 2.8V, 3.0V, 3.3V. It is designed to work with low-ESR ceramic capacitor, reducing the amount of the PCB area. Only a 1 μ F ceramic output capacitor can make the device stable over the whole load range.

As shown in the function block diagram, the TMI6038 is composed of the bandgap reference voltage, the error amplifier, P-channel MOSFET pass transistor, internal resistor divider and some additional protection circuits. The reference voltage, connected to the cathode terminal of the error amplifier, compares with the feedback voltage to regulate the output voltage to make it constant over the whole load current range. If the feedback voltage is lower than the reference voltage, the pass transistor gate is pulled lower to increase its conductivity. This allows more current to flow to the output and increase the output voltage. If the feedback voltage is higher than the reference voltage, the pass transistor gate is pulled higher to decrease its conductivity. This allows less current to flow to the output and decrease the output voltage. The feedback point is the output of the internal resistor divider connected to the V_{OUT} pin.

Enable/Shutdown

The TMI6038 is disabled when the EN pin is connected to ground or the voltage less than 0.4V, and the shutdown current is less than 0.1 μ A. Connect EN pin to 1.5V or higher voltage to enable the device. This EN pin cannot be floated.

Output Auto Discharge

When the regulator is disabled, an internal 100 Ω resistor is connected between V_{OUT} and GND to discharge output capacitor C_{OUT} .

Current Limit

The TMI6038 includes a current limit circuit to monitor the gate voltage of the pass transistor to limit the output current. When the output current is higher than the over-current limit, the circuit will clamp the gate voltage of the pass transistor to limit the output current.

Thermal Shutdown

The TMI6038 monitors internal temperature. When the junction temperature exceeds 160°C, the over temperature protection (OTP) circuit turn off the pass transistor until the device is cooled down by 20°C. Then the pass transistor resumes. For continue operation, do not exceed absolute maximum junction temperature.

Application Information

Input capacitor

A 1μF or higher capacitance value ceramic capacitor is required between the VIN pin and the GND pin. Place it as close as possible to the device. There are no requirements for the ESR on the input capacitor, but the tolerance and temperature coefficient must be considered. The ceramic capacitor with 1μF or larger rating capacitance, X5R or X7R type dielectrics and 0402 or larger size is recommended as input capacitor.

Output capacitor

An output capacitor (C_{OUT}) is needed to improve transient response and maintain stability. The TMI6038 is stable with very small ceramic output capacitors. A 1μF to 10μF capacitor is suitable for the most TMI6038 applications. For typical application, the ceramic capacitor with 1μF or larger rating capacitance, X5R or X7R type dielectrics and 0402 or larger size is recommended as output capacitor.

Package Information

SOT23-5

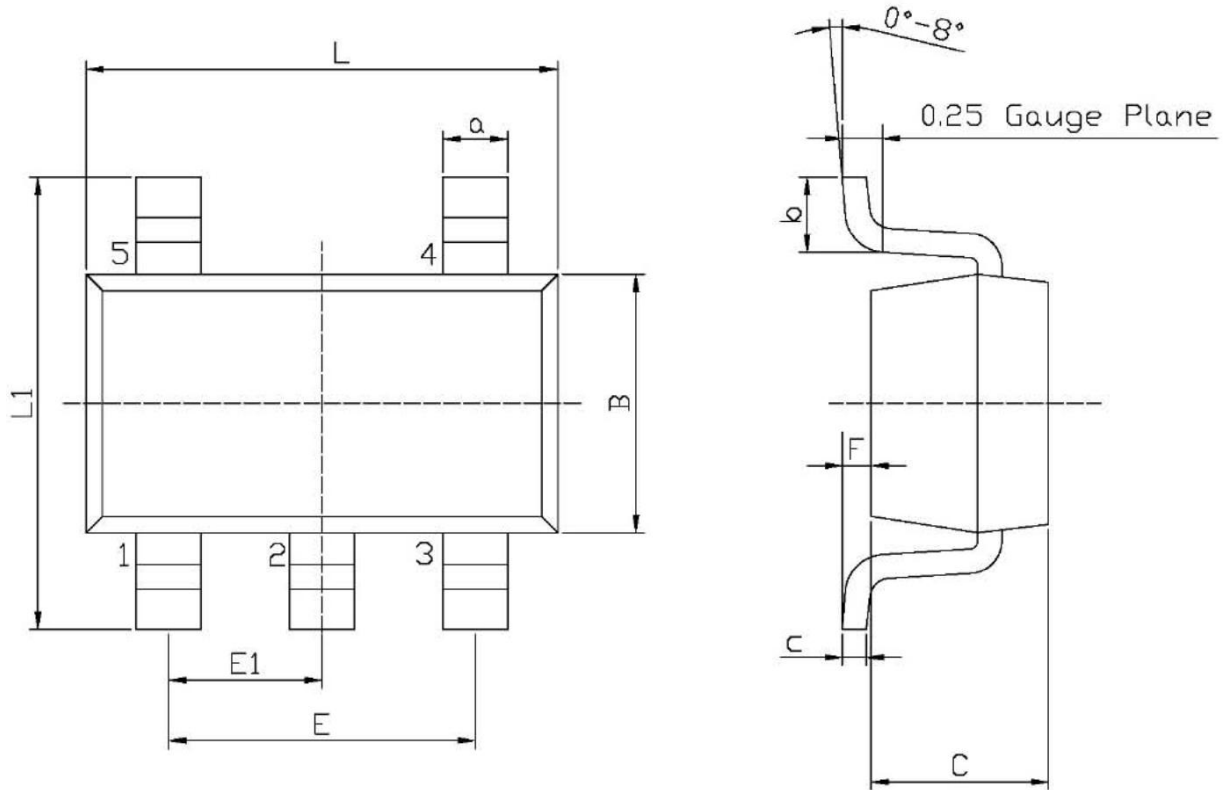

Unit: mm

| Symbol | Dimensions In Millimeters | | Symbol | Dimensions In Millimeters | |
|--------|---------------------------|------|--------|---------------------------|------|
| | Min | Max | | Min | Max |
| L | 2.82 | 3.02 | E1 | 0.85 | 1.05 |
| B | 1.50 | 1.70 | a | 0.35 | 0.50 |
| C | 0.90 | 1.30 | c | 0.10 | 0.20 |
| L1 | 2.60 | 3.00 | b | 0.35 | 0.55 |
| E | 1.80 | 2.00 | F | 0 | 0.15 |

Note:

- 1) All dimensions are in millimeters.
- 2) Package length does not include mold flash, protrusion or gate burr.
- 3) Package width does not include inter lead flash or protrusion.
- 4) Lead popularity (bottom of leads after forming) shall be 0.10 millimeters max.
- 5) Pin 1 is lower left pin when reading top mark from left to right.

Tape and Reel Information

TAPE DIMENSIONS: SOT23-5

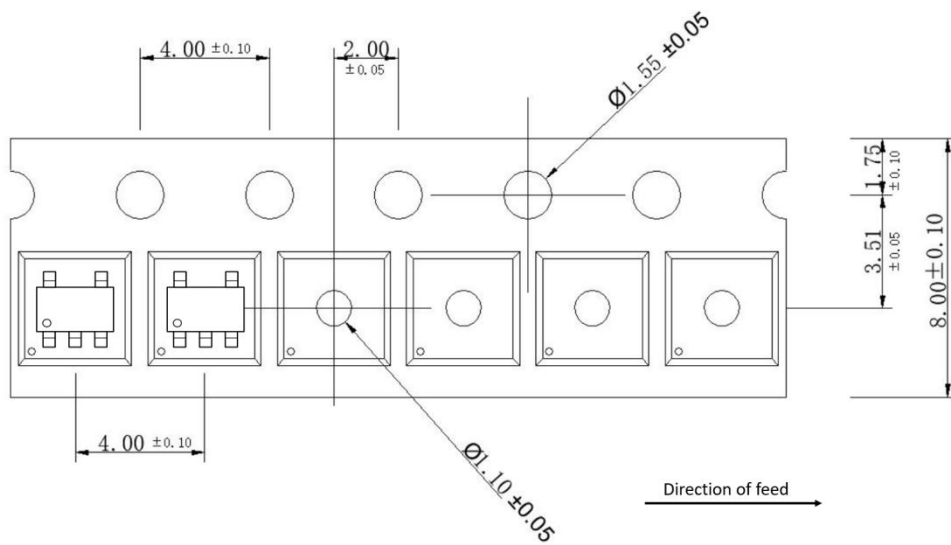

REEL DIMENSIONS: SOT23-5

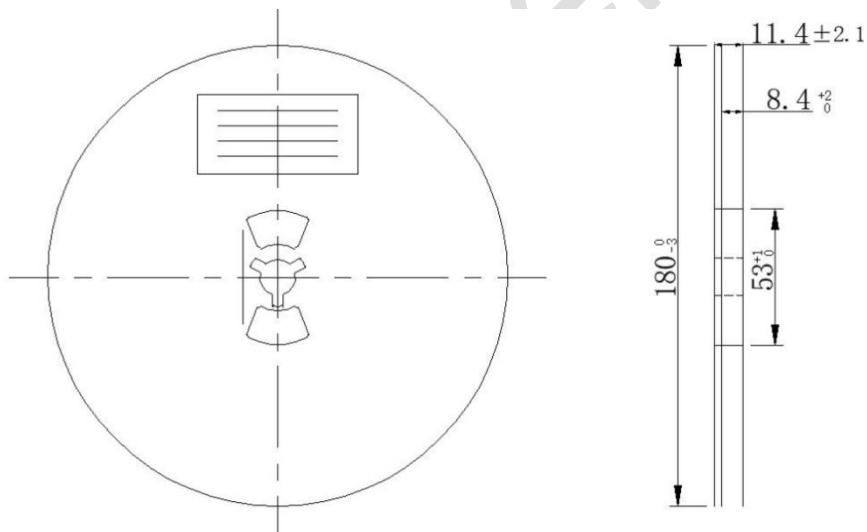

Note:

- 1) All Dimensions are in Millimeter
- 2) Quantity of Units per Reel is 3000
- 3) MSL level is level 3.

Important Notification

This document only provides product information. TOLL Microelectronic Inc. (TMI) reserves the right to make corrections, modifications, enhancements, improvements, and other changes to its products and to discontinue any product without notice at any time.

TOLL Microelectronic Inc. (TMI) cannot assume responsibility for use of any circuitry other than circuitry entirely embodied in a TMI product. No circuit patent licenses are implied.

All rights are reserved by TOLL Microelectronic Inc.
[http:// www.toll-semi.com](http://www.toll-semi.com)