

Jun.1.2019 Copyright 2019 HIROSE ELECTRIC CO., LTD. All Rights Reserved.
In case of consideration for using Automotive equipment / device which demand high reliability, kindly contact our sales window correspondents.

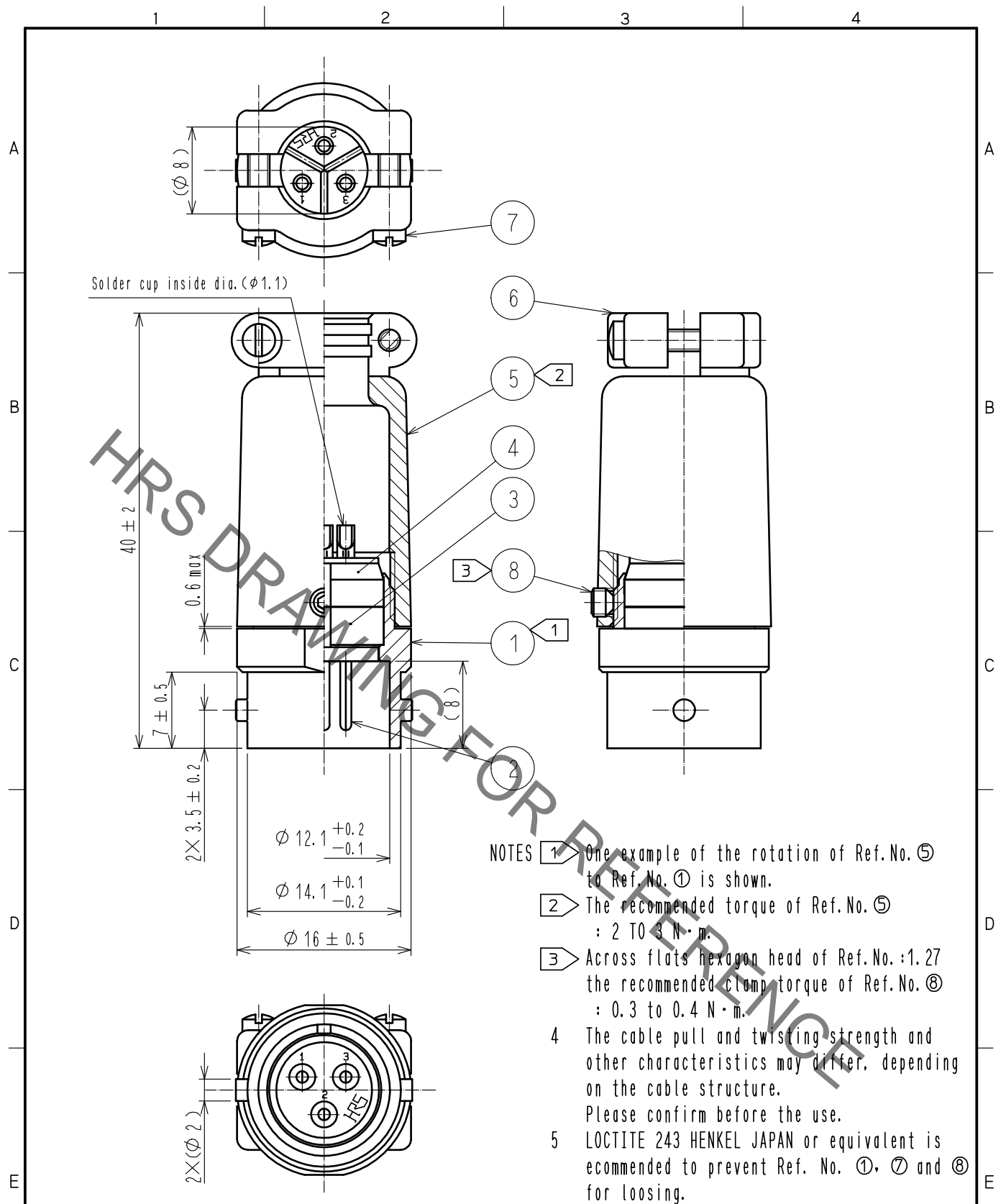

- NOTES
- ① One example of the rotation of Ref. No. ⑤ to Ref. No. ① is shown.
 - ② The recommended torque of Ref. No. ⑤ : 2 TO 3 N·m.
 - ③ Across flats hexagon head of Ref. No. :1.27 the recommended clamp torque of Ref. No. ⑧ : 0.3 to 0.4 N·m.
 - ④ The cable pull and twisting strength and other characteristics may differ, depending on the cable structure. Please confirm before the use.
 - ⑤ LOCTITE 243 HENKEL JAPAN or equivalent is recommended to prevent Ref. No. ①, ⑦ and ⑧ for loosening.

4	DIALYL PHTHALATE	(BLACK) UL94V-0	8	STEEL	NICKEL PLATING
3	DIALYL PHTHALATE	(BLACK) UL94V-0	7	BRASS	NICKEL PLATING
2	COPPER ALLOY	SILVER PLATING 2 μm min.	6	ZINC ALLOY	MATTE FINISH NICKEL PLATED
1	ZINC ALLOY	MATTE FINISH NICKEL PLATED	5	ZINC ALLOY	MATTE FINISH NICKEL PLATED
NO.	MATERIAL	FINISH . REMARKS	NO.	MATERIAL	FINISH . REMARKS

UNITS mm		SCALE 2 : 1	COUNT 	DESCRIPTION OF REVISIONS	DESIGNED	CHECKED	DATE
HIROSE ELECTRIC CO., LTD.				APPROVED :HY. KOBAYASHI 15.10.27 CHECKED :HY. KOBAYASHI 15.10.27 DESIGNED :HT. ZENBA 15.10.26 DRAWN :HT. ZENBA 15.10.26	DRAWING NO. EDC-027935-00-00 PART NO. RM12BJB-3PH CODE NO. CL109-0830-3-00		