

SOT-143 Plastic-Encapsulate Diodes

DESCRIPTION

SR05LC provides a typical line to line capacitance of 0.6pF and low insertion loss up to 3GHz providing greater signal integrity making it ideally suited for USB 2.0 applications, such as Digital TVs, DVD players, Computing, set-top boxes and MDDI applications in mobile computing devices.

This device has been specifically designed to protect sensitive components which are connected to high-speed data and transmission lines from overvoltage caused by ESD (electrostatic discharge), CDE (Cable Discharge Events), and EFT (electrical fast transients).

Features

- ◆ Protects two I/O lines and one Vcc line
- ◆ Transient protection for asymmetrical data lines to IEC61000-4-2 (ESD) $\pm 30\text{kV}$ (air), $\pm 30\text{kV}$ (contact) IEC61000-4-4 (EFT) 40A (5/50ns)
- ◆ Low capacitance
- ◆ Low leakage current
- ◆ Low clamping voltage
- ◆ No insertion to 3.0 GHz
- ◆ 5V operating voltage
- ◆ Response time < 1ns
- ◆ Solid-state silicon avalanche technology
- ◆ Meets MSL 1 Requirements

Schematic & Pin Configuration ROHS COMPLIANT

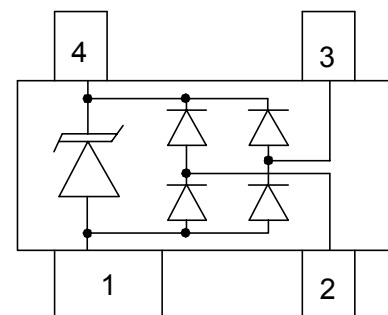

SOT-143 (Top View)

Circuit Diagram

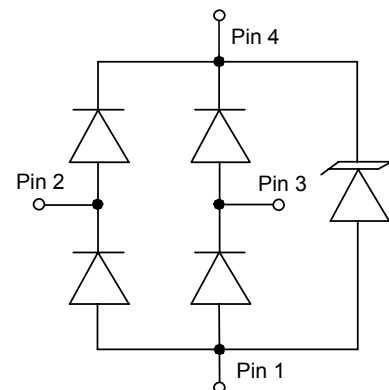

Applications

- ◆ xDSL
- ◆ USB 1.1/2.0/OTG
- ◆ IEEE 1394 Firewire Ports
- ◆ Notebooks & Handhelds
- ◆ Projection TV & Monitors
- ◆ Set-top box
- ◆ Flat Panel Displays

Mechanical Characteristics

- ◆ Package: SOT-143
- ◆ Flammability Rating: UL 94V-0
- ◆ Terminal: Matte tin plated.
- ◆ High temperature soldering guaranteed: 260°C/10s
- ◆ Marking: SL3 or R05
- ◆ Packaging: Tape and Reel

Absolute Maximum Ratings ($T_A=25^{\circ}\text{C}$ unless otherwise specified)

Parameter	Symbol	Value	Unit
Peak Pulse Power(8/20us)	P _{PP}	125	W
Peak Pulse Current(8/20us)	I _{PP}	5	A
ESD per IEC 61000-4-2 (Air) ESD per IEC 61000-4-2 (Contact)	V _{ESD}	± 30 ± 30	KV
Operating Temperature	T _{OPT}	-55 to +150	°C
Storage Temperature	T _{STG}	-55 to +150	°C
Lead Solder Temperature – Maximum (10 Second Duration)	T _L	260(10 sec.)	°C

Electrical Characteristics ($T_A=25^{\circ}\text{C}$ unless otherwise specified)

Symbol	Parameter	Test Condition	Min	Typ	Max	Units
V _{RWM}	Reverse Working Voltage	Any I/O pin to GND			5.0	V
V _{BR}	Reverse Breakdown Voltage	I _T = 1mA Any I/O pin to GND	6.0			V
I _R	Reverse Leakage Current	V _{RWM} = 5V Any I/O pin to GND			1	μA
V _F	Diode Forward Voltage	I _F = 15mA		0.85	1.2	V
V _{C1}	Clamping Voltage 1	I _{PP} = 1A, t _p = 8/20μs Any I/O pin to GND			15.5	V
V _{C2}	Clamping Voltage 2	I _{PP} = 5A, t _p = 8/20μs Any I/O pin to GND			25	V
I _{PP}	Peak Pulse Current	t _p = 8/20μs Any I/O pin to GND			5	A
C _{J1}	Junction Capacitance 1	V _R = 0V, f = 1MHz Between I/O pins		0.45	0.6	pF
C _{J2}	Junction Capacitance 2	V _R = 0V, f = 1MHz Any I/O pin to GND		0.9	1.2	pF

Note: I/O pins are pin2,3.

The above data are for reference only.

ELECTRICAL CHARACTERISTICS CURVE

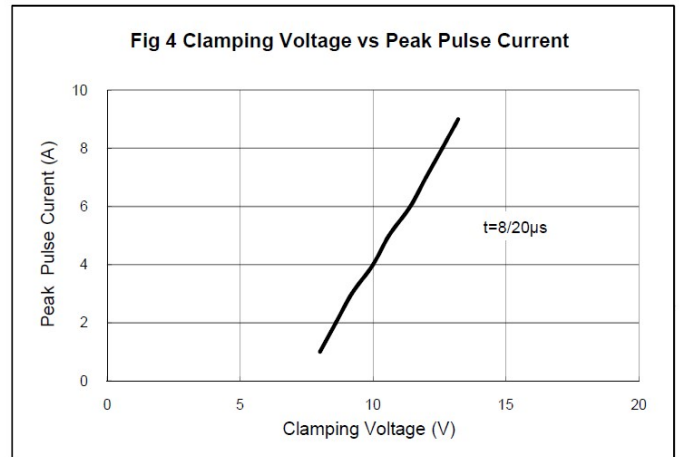
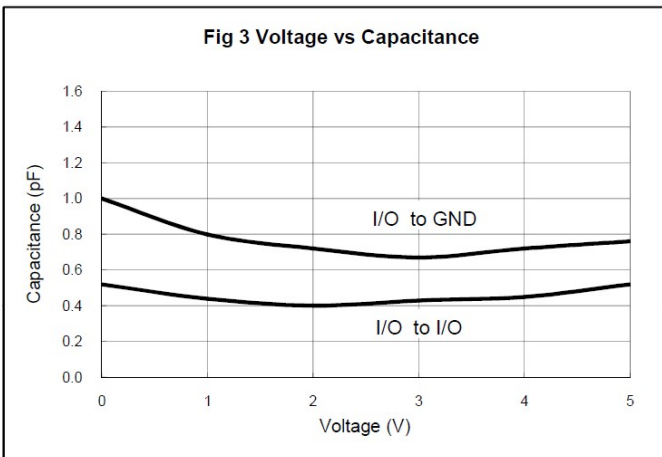
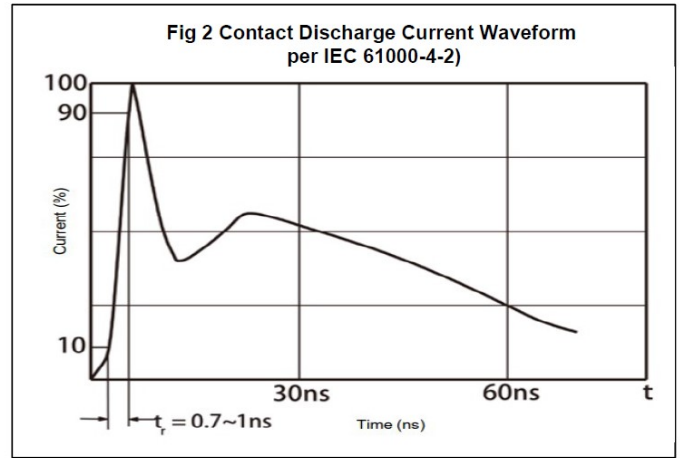
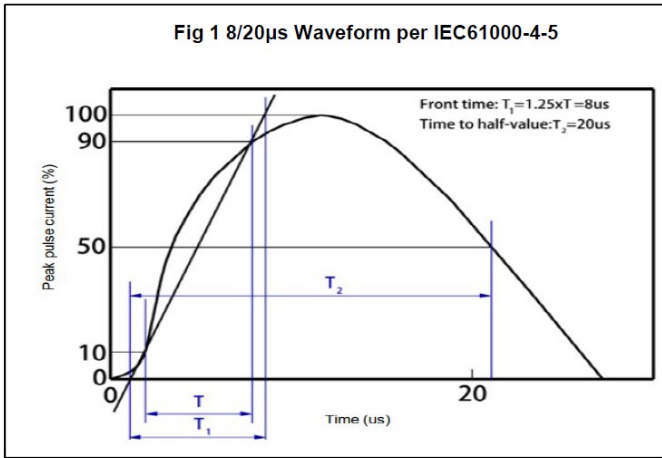

The curve above is for reference only.

Outlitne Drawing

SOT-143 Package Outline Dimensions

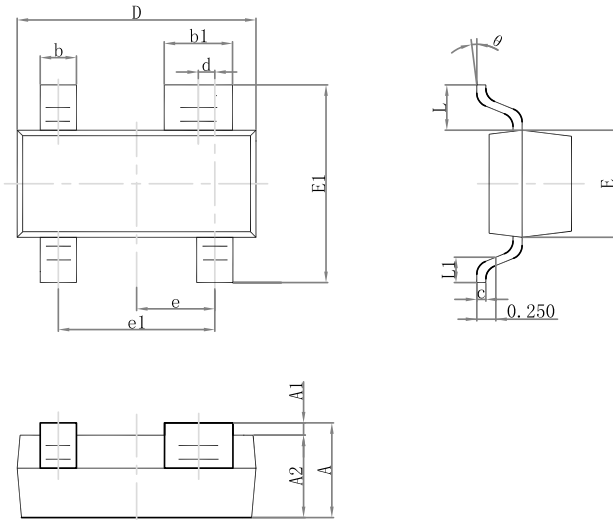

Symbol	Dimensions In Millimeters		Dimensions In Inches	
	Min.	Max.	Min.	Max.
A	0.900	1.150	0.035	0.045
A1	0.000	0.100	0.000	0.004
A2	0.900	1.050	0.035	0.041
b	0.300	0.500	0.012	0.020
b1	0.750	0.900	0.030	0.035
c	0.080	0.150	0.003	0.006
D	2.800	3.000	0.110	0.118
d	0.200 TYP.		0.008 TYP.	
E	1.200	1.400	0.047	0.055
E1	2.250	2.550	0.089	0.100
e	0.950 TYP.		0.037 TYP.	
e1	1.800	2.000	0.071	0.079
L	0.550 REF.		0.022 REF.	
L1	0.300	0.500	0.012	0.020
θ	0°	8°	0°	8°

Suggested Pad Layout

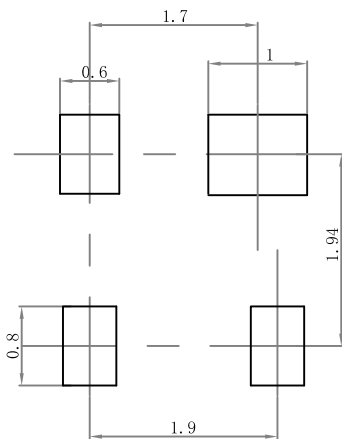

Note:

1. Controlling dimension:in/millimeters.
2. General tolerance: ±0.05mm.
3. The pad layout is for reference purposes only.

Tape and Reel Information

SOT-143 Embossed Carrier Tape

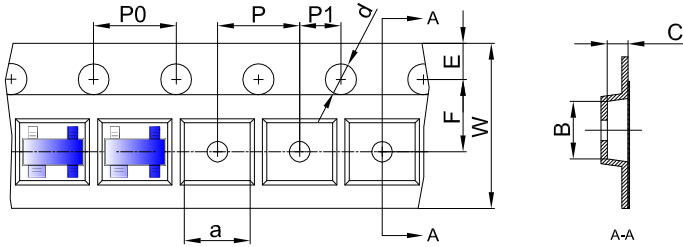

Packaging Description:

SOT-143 parts are shipped in tape. The carrier tape is made from a dissipative (carbon filled) polycarbonate resin. The cover tape is a multilayer film (Heat Activated Adhesive in nature) primarily composed of polyester film, adhesive layer, sealant, and anti-static sprayed agent. These reeled parts in standard option are shipped with 3,000 units per 7" or 17.8cm diameter reel. The reels are clear in color and is made of polystyrene plastic (anti-static coated).

Dimensions are in millimeter

Pkg type	a	B	C	d	E	F	P0	P	P1	W
SOT-143	3.19	2.80	1.31	Ø1.50	1.75	3.50	4.00	4.00	2.00	8.00

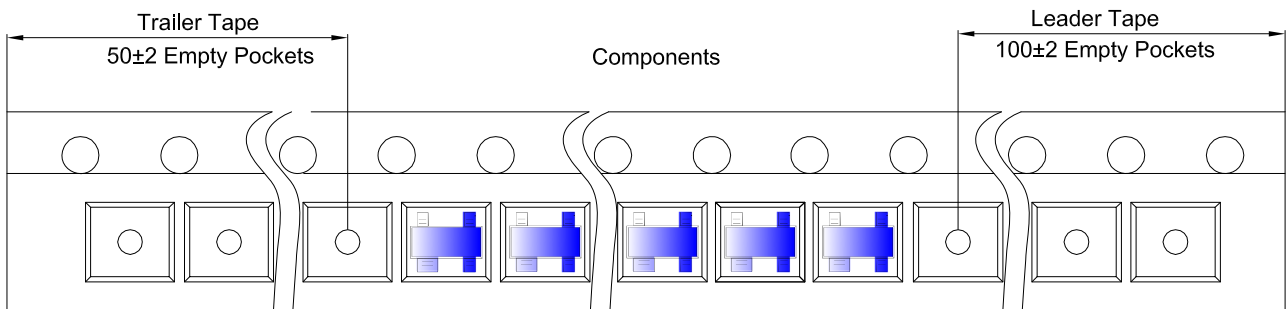
SOT-143 Tape Leader and Trailer



SOT-143 Reel

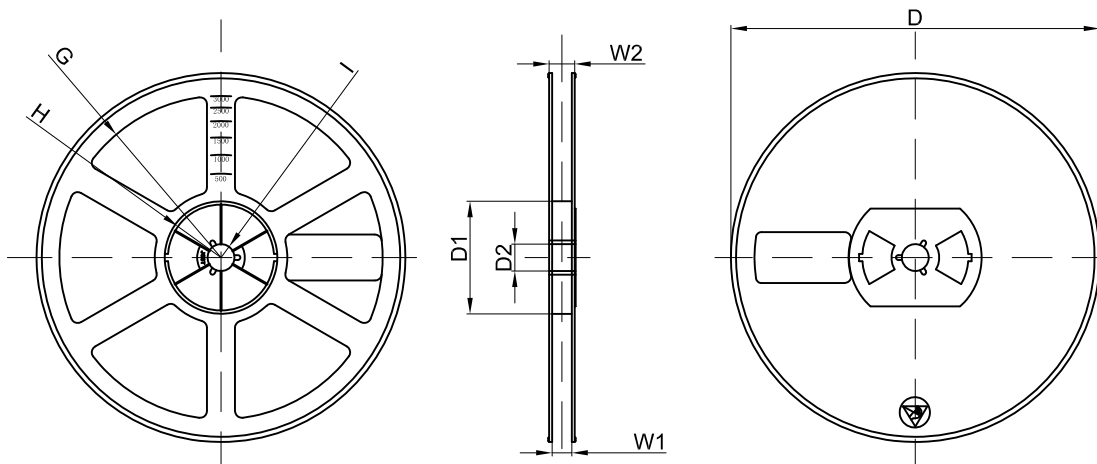

Dimensions are in millimeter

Reel Option	D	D1	D2	G	H	I	W1	W2
7" Dia	Ø178.00	54.40	13.00	R78.00	R25.60	R6.50	9.50	12.30

REEL	Reel Size	Box	Box Size(mm)	Carton	Carton Size(mm)	G.W.(kg)
3000 pcs	7 Inch	45,000 pcs	203×203×195	180,000 pcs	438×438×220	