

M51943A,B/M51944A,B

VOLTAGE DETECTING, SYSTEM RESETTNG IC SERIES

DESCRIPTION

M51943A,B/M51944A,B are semiconductor integrated circuits designed for detecting supply voltage and resetting all types of logic circuits such as CPUs.

They find extensive applications, including battery checking circuit, level detecting circuit and waveform shaping circuit.

FEATURES

- Few external parts
- Low threshold operating voltage (Supply voltage to keep low-state at low supply voltage)
 - 0.6V (TYP.) at $R_L = 22k\Omega$
- Wide supply voltage range 2 ~ 17V
- Sudden change in power supply has minimal effect on the ICs
- Wide application range
- SIL package of the same height as DIP (5-pin SIP)
- Extra small 3-pin package (3-pin FALT)

APPLICATION

Reset circuit of Pch, Nch, CMOS, microcomputer, CPU and microcomputer, Reset of logic circuit, Battery check circuit, Switching circuit back-up voltage, Level detecting circuit, Waveform shaping circuit, Delay waveform generating circuit, DC-DC converter, Over voltage protection circuit.

RECOMMENDED OPERATING CONDITION

Supply voltage range 2 ~ 17V

PIN CONFIGURATION

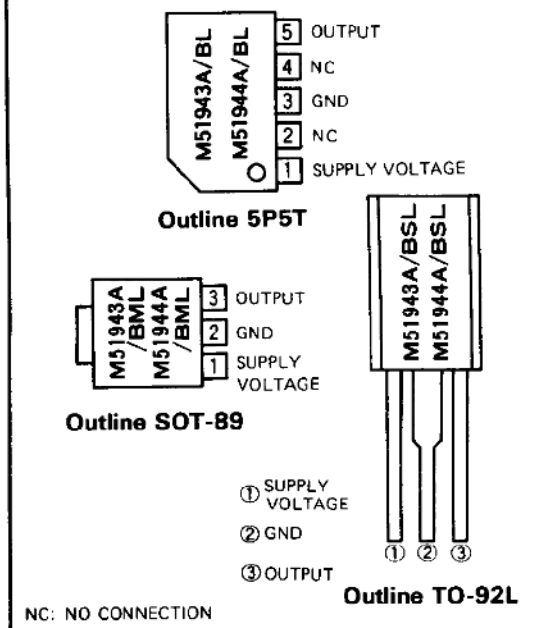

BLOCK DIAGRAM

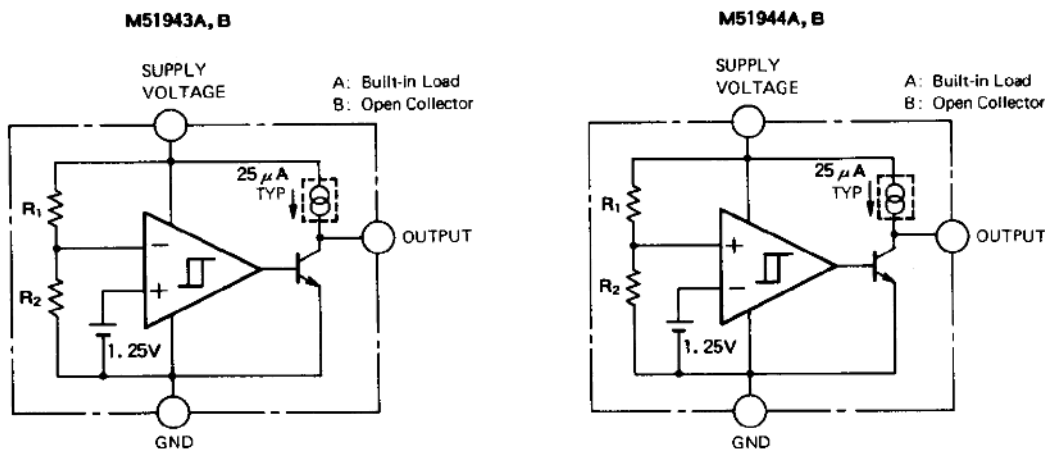

MITSUBISHI <Dig./Ana. INTERFACE>
M51943A,B/M51944A,B

VOLTAGE DETECTING, SYSTEM RESETTNG IC SERIES

FUNCTION DIAGRAM

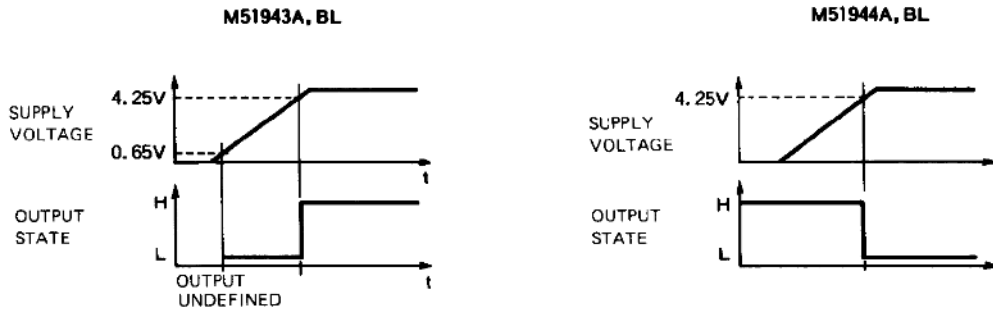

ABSOLUTE MAXIMUM RATINGS ($T_a = 25^\circ\text{C}$, unless otherwise noted)

Symbol	Parameter	Conditions	Ratings	Unit	
V_{CC}	Supply voltage		18	V	
I_{sink}	Output Sink Current		6	mA	
V_O	Output voltage	A Type (Output with constant current load)	V_{CC}	V	
		B Type (Open collector output)	18		
P_d	Power dissipation	5P SIL	450	mW	
		3P SIL	700		
		3P FLAT	500		
K_θ	Thermal Derating	$T_a \geq 25^\circ\text{C}$	5P SIL	4.5	mW/ $^\circ\text{C}$
			3P SIL	7	
			3P FLAT	5	
T_{opr}	Operating temperature		$-30 \sim +85$	$^\circ\text{C}$	
T_{stg}	Storage temperature		$-40 \sim +125$	$^\circ\text{C}$	

ELECTRICAL CHARACTERISTICS ($T_a = 25^\circ\text{C}$, unless otherwise noted)

"L" reset type	"H" reset type
M51943A	M51944A
M51943B	M51944B

Symbol	Parameter	Test conditions	Limits			Unit	
			Min	Typ	Max		
V_S	Detecting voltage		4.05	4.25	4.45	V	
ΔV_S	Hysteresis voltage		30	50	80	mV	
$V_S/\Delta T$	Detecting voltage Temperature Coefficient		—	0.01	—	%/ $^\circ\text{C}$	
I_{CC}	Circuit Current	A type $V_{CC} = 5V$	—	370	560	μA	
		B type $V_{CC} = 5V$	—	370	510		
V_{sat}	Output Saturation Voltage	L reset type $V_{CC} = 4V, I_{sink} = 4mA$	—	0.2	0.4	V	
		H reset type $V_{CC} = 5V, I_{sink} = 4mA$	—	0.2	0.4		
V_{OPL}	Threshold Operating voltage	L reset type Minimum supply voltage for IC operation	$R_L = 2.2k\Omega, V_{sat} \leq 0.4V$	—	0.67	0.8	V
			$R_L = 100k\Omega, V_{sat} \leq 0.4V$	—	0.55	0.7	
I_{OH}	Output Leakage Current	B type	—	—	30	nA	
		B Type $T_a = -30 \sim +85^\circ\text{C}$	—	—	1	μA	
I_{OC}	Output Load Current	A type $V_{CC} = 5V, V_O = 1/2 \times V_{CC}$	-40	-25	-17	μA	
V_{OH}	Output High Voltage	A type	$V_{CC} - 0.2$	$V_{CC} - 0.06$	—	V	
t_{PHL}	Propagation Delay Time	Response time when V_{CC} changes H \rightarrow L	—	6	—	μs	
t_{PLH}		Response time when V_{CC} changes L \rightarrow H	—	3	—	μs	

VOLTAGE DETECTING, SYSTEM RESETTIC IC SERIES

TYPICAL CHARACTERISTICS

**TYPICAL CHARACTERISTICS
 THERMAL DERATING
 (MAXIMUM RATING)**

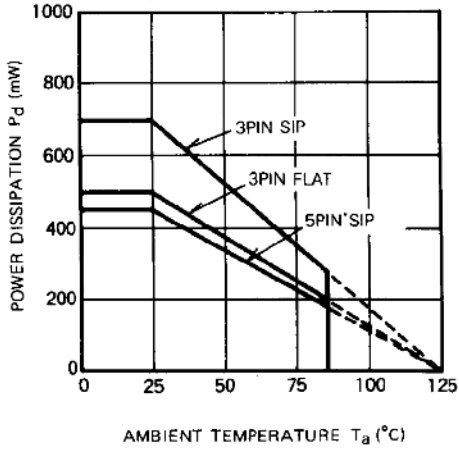

**DETECTING VOLTAGE VS.
 AMBIENT TEMPERATURE
 (Supply voltage detecting series)**

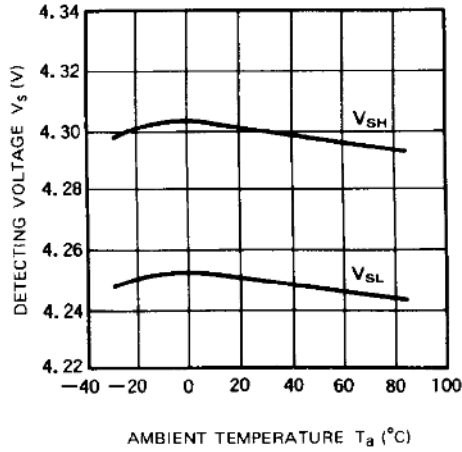

**THRESHOLD OPERATING VOLTAGE
 ([L] reset type)**

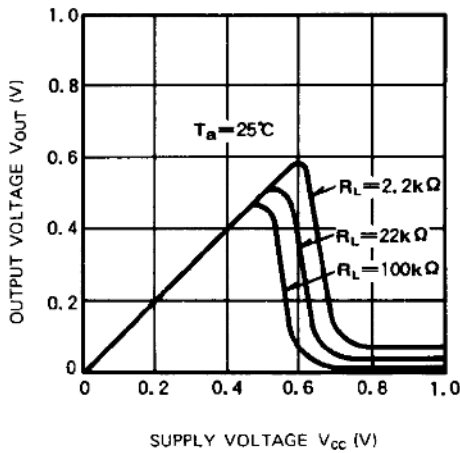

**OUTPUT SATURATION VOLTAGE VS.
 OUTPUT SINK CURRENT**

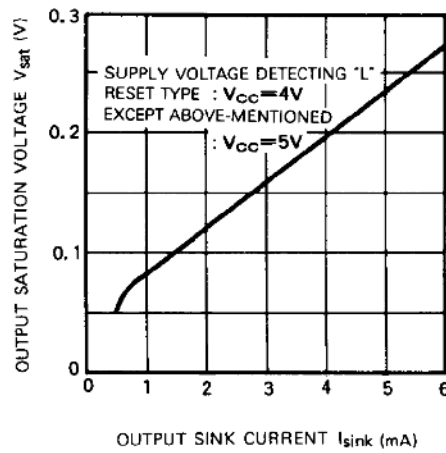

**OUTPUT LOAD CURRENT VS.
 OUTPUT VOLTAGE
 (M519XXA)**

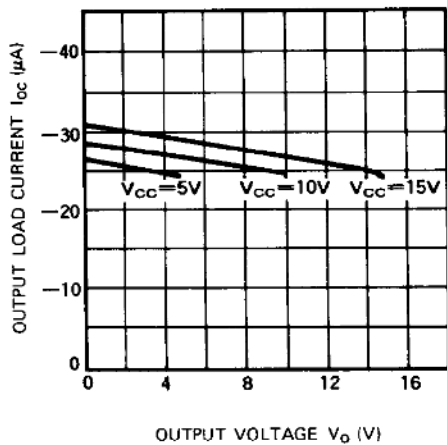

**CIRCUIT CURRENT VS.
 AMBIENT TEMPERATURE
 (M51943B, M51944B)**

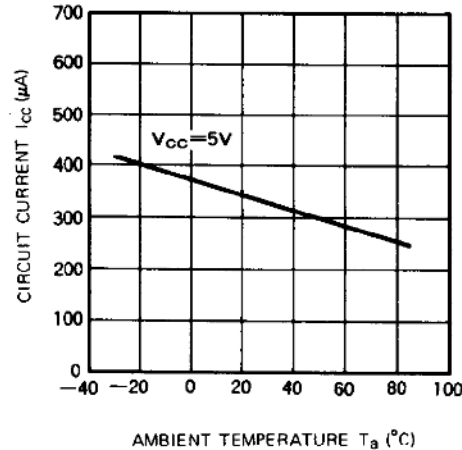

VOLTAGE DETECTING, SYSTEM RESETTING IC SERIES

EXAMPLE OF APPLICATION CIRCUIT

Reset Circuit of M5194XX Series

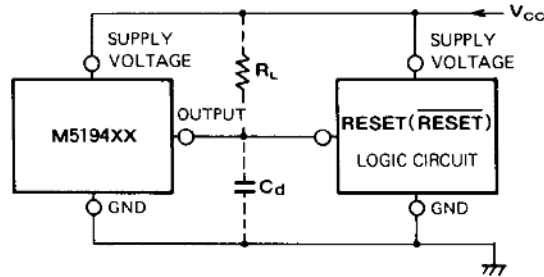

Note 1. When the detecting supply voltage is 4.25V, M51943 and M51944 are used. When the voltage is anything except 4.25V, M51945 and M51946 are used.

Note 2. If the M5194XX and the logic circuit share a common power source, type A (built-in load type) can be used whether a pull-up resistor is included in the logic circuit or not.

Note 3. The logic circuit preferably should not have a pull-down resistor, but if one is present, add load resistor R_L to overcome the pull-down resistor.

Note 4. It is better to use the M5195XX series to cause a delay, but if the delay is caused by the M5194XX series, the delay capacitor C_d is applied between the output and GND.

Note 5. When the reset terminal in the logic circuit is of the low reset type, M51943 and M51945 are used and when the terminal is of the high reset type, M51944 and M51946 are used.

Note 6. When a negative supply voltage is used, the supply voltage side of M5194XX and the GND side are connected to GND and the negative supply voltage respectively.